

aprilia

1056-1

01/2001-12

v990 engine 

www.aprilia.com

workshop manual

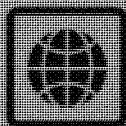
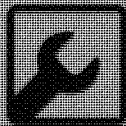
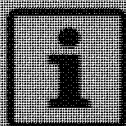

© APRILIA 

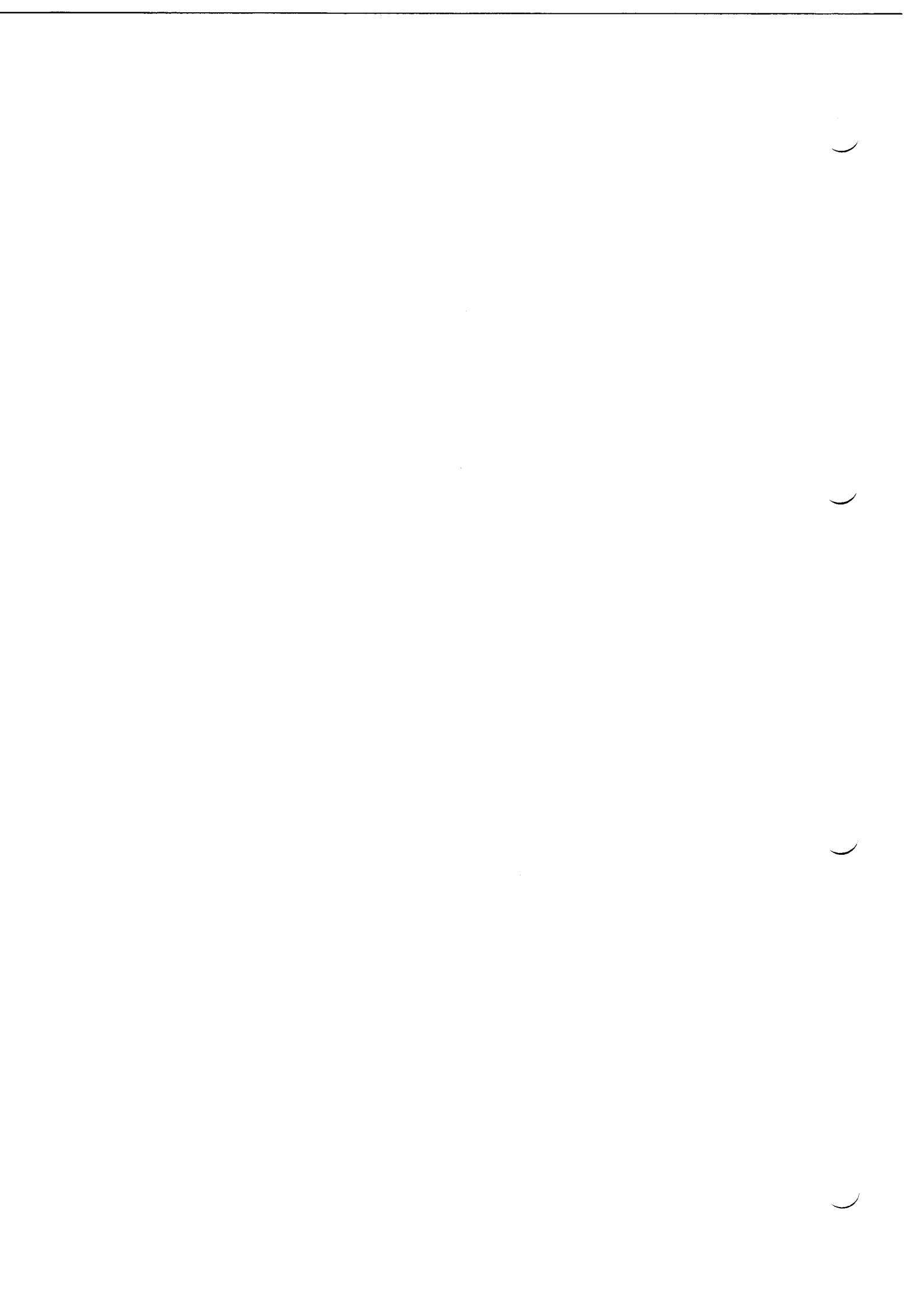

INTRODUCTION	0
GENERAL INFORMATION	1
TECHNICAL INFORMATION	2
REMOVING/REFITTING THE COMPLETE ENGINE FROM/TO THE VEHICLE FRAME	3
DISASSEMBLING THE ENGINE	4
WORK ON THE ENGINE INDIVIDUAL PARTS	5
REASSEMBLING THE ENGINE	6
FUEL SYSTEM, COOLING SYSTEM, ELECTRICAL SYSTEM	7
TROUBLESHOOTING	8
ANALYTICAL INDEX	<i>i</i>



V990 engine 1056-1 



workshop manual



aprilia part# 8140587

0 INTRODUCTION**TABLE OF CONTENTS**

0.1 UPDATE OF RELEASE 01/2001-12	0-3-00
0.1.1 INFORMATION ON THE UPDATING OF THE MANUAL	0-3-00
0.1.2 UPDATED MANUAL GENERAL LIST ...	0-3-00
0.2 HOW TO CONSULT THE MANUAL	0-5-00
0.3 FOREWORD	0-6-00
0.4 REFERENCE aprilia SERVICE LITERATURE	0-6-00
0.4.1 VEHICLE WORKSHOP MANUAL	0-6-00
0.4.2 SPARE PARTS CATALOGUE	0-6-00
0.4.3 SPECIAL TOOLS CATALOGUE	0-6-00
0.4.4 USE AND MAINTENANCE BOOK	0-6-00
0.5 ABBREVIATIONS/ SYMBOLS/INITIALS	0-7-00

0.1 UPDATE OF RELEASE 01/2001-12

Date of the first edition (Release 00) and of the following Releases:

First edition (Release 00) November 2001
 Release 01 December 2001

0.1.1 INFORMATION ON THE UPDATING OF THE MANUAL

The manual must be updated every time a new "Release" is received.

Insert the pages of the last Release in the manual and eliminate the corresponding obsolete pages (even if belonging to a previous Release).

⚠ WARNING

The failure to update the manual and to eliminate the obsolete pages makes it more difficult to consult the manual and may lead to the performance of incorrect operations on the engine, with serious consequences for the safety of the engine, the vehicle and of persons and property.

The manual consists of # 10 sections, for a total amount of # 184 pages, as listed below.

NOTE For the nomenclature of the standard page of the manual (and specifically for the definition of the page number), see 0.2 (HOW TO CONSULT THE MANUAL).

0.1.2 UPDATED MANUAL GENERAL LIST

page#	Release	page#	Release		
0 - 1	- 00	00	2 - 14	- 00	00
0 - 2	- 00	01	2 - 15	- 00	00
0 - 3	- 00	01	2 - 16	- 00	01
0 - 4	- 00	01	2 - 17	- 00	01
0 - 5	- 00	00	2 - 18	- 00	01
0 - 6	- 00	01	2 - 19	- 00	01
0 - 7	- 00	01	2 - 20	- 00	01
0 - 8	- 00	00	2 - 21	- 00	00
1 - 1	- 00	00	2 - 22	- 00	00
1 - 2	- 00	00	3 - 1	- 00	00
1 - 3	- 00	00	3 - 2	- 00	00
1 - 4	- 00	00	4 - 1	- 00	00
1 - 5	- 00	00	4 - 2	- 00	01
1 - 6	- 00	00	4 - 3	- 00	00
1 - 7	- 00	00	4 - 4	- 00	00
1 - 8	- 00	00	4 - 5	- 00	01
1 - 9	- 00	01	4 - 6	- 00	01
1 - 10	- 00	00	4 - 7	- 00	01
2 - 1	- 00	00	4 - 8	- 00	01
2 - 2	- 00	00	4 - 9	- 00	01
2 - 3	- 00	00	4 - 10	- 00	00
2 - 4	- 00	01	4 - 11	- 00	01
2 - 5	- 00	01	4 - 12	- 00	00
2 - 6	- 00	01	4 - 13	- 00	01
2 - 6	- 01	01	4 - 14	- 00	01
2 - 6	- 02	01	4 - 14	- 01	01
2 - 7	- 00	01	4 - 14	- 02	01
2 - 8	- 00	01	4 - 15	- 00	00
2 - 9	- 00	01	4 - 16	- 00	01
2 - 10	- 00	00	4 - 17	- 00	01
2 - 11	- 00	01	4 - 18	- 00	01
2 - 12	- 00	00	4 - 19	- 00	00
2 - 13	- 00	01	4 - 20	- 00	01

page#	Release	page#	Release		
4 - 21	- 00	00	5 - 53	- 00	01
4 - 22	- 00	01	5 - 53	- 01	01
4 - 23	- 00	01	5 - 53	- 02	01
4 - 24	- 00	00	5 - 53	- 03	01
5 - 1	- 00	00	5 - 53	- 04	01
5 - 2	- 00	01	5 - 54	- 00	01
5 - 3	- 00	00	6 - 1	- 00	00
5 - 4	- 00	01	6 - 2	- 00	01
5 - 5	- 00	01	6 - 3	- 00	01
5 - 6	- 00	01	6 - 4	- 00	01
5 - 7	- 00	00	6 - 5	- 00	01
5 - 8	- 00	00	6 - 6	- 00	01
5 - 9	- 00	01	6 - 7	- 00	00
5 - 10	- 00	00	6 - 8	- 00	00
5 - 11	- 00	01	6 - 9	- 00	00
5 - 12	- 00	00	6 - 10	- 00	00
5 - 13	- 00	01	6 - 11	- 00	00
5 - 14	- 00	00	6 - 12	- 00	01
5 - 15	- 00	01	6 - 13	- 00	01
5 - 16	- 00	01	6 - 14	- 00	01
5 - 17	- 00	01	6 - 15	- 00	00
5 - 18	- 00	00	6 - 16	- 00	00
5 - 19	- 00	00	6 - 17	- 00	01
5 - 20	- 00	00	6 - 18	- 00	01
5 - 21	- 00	00	6 - 19	- 00	00
5 - 22	- 00	00	6 - 20	- 00	00
5 - 23	- 00	00	6 - 21	- 00	00
5 - 24	- 00	00	6 - 22	- 00	00
5 - 25	- 00	00	6 - 23	- 00	01
5 - 26	- 00	01	6 - 24	- 00	01
5 - 27	- 00	01	6 - 25	- 00	00
5 - 28	- 00	01	6 - 26	- 00	00
5 - 28	- 01	01	6 - 27	- 00	01
5 - 28	- 02	01	6 - 28	- 00	00
5 - 29	- 00	01	6 - 29	- 00	01
5 - 29	- 01	01	6 - 30	- 00	01
5 - 29	- 02	01	6 - 31	- 00	01
5 - 29	- 03	01	6 - 32	- 00	00
5 - 29	- 04	01	6 - 33	- 00	00
5 - 30	- 00	01	6 - 34	- 00	00
5 - 31	- 00	01	7 - 1	- 00	00
5 - 32	- 00	01	7 - 2	- 00	00
5 - 33	- 00	01	8 - 1	- 00	00
5 - 34	- 00	01	8 - 2	- 00	00
5 - 35	- 00	01	① - 1	- 00	01
5 - 36	- 00	01	① - 2	- 00	01
5 - 37	- 00	01	① - 3	- 00	01
5 - 38	- 00	01	① - 4	- 00	01
5 - 39	- 00	01	① - 5	- 00	01
5 - 40	- 00	01	① - 6	- 00	01
5 - 41	- 00	01	① - 7	- 00	01
5 - 42	- 00	01	① - 8	- 00	01
5 - 43	- 00	01	① - 9	- 00	01
5 - 44	- 00	01	① - 10	- 00	01
5 - 45	- 00	01			
5 - 46	- 00	01			
5 - 47	- 00	01			
5 - 48	- 00	01			
5 - 49	- 00	01			
5 - 49	- 01	01			
5 - 49	- 02	01			
5 - 50	- 00	01			
5 - 51	- 00	01			
5 - 52	- 00	01			

NOTE

Lined area for notes, currently blank.

THIS PAGE HAS BEEN INTENTIONALLY LEFT EMPTY

0.2 HOW TO CONSULT THE MANUAL

GENERAL INFORMATION

8 [**1.15 PLACING THE VEHICLE ON THE SUPPORT STAND**

9 [**1.15.1 ASSEMBLING THE PINS FOR THE REAR SUPPORT STAND ^{OPT}**

10 [**NOTE** Have the special tool ^{OPT} available:
 – **aprilia** part# 8705021 (rear support stand with appropriate pins).

- ◆ Place the vehicle on the stand.
- ◆ ★ Place the pin (1) on the appropriate seat on the swinging arm.
- ◆ ★ Screw and tighten the screw (2) in the appropriate threaded hole (3) in the swinging arm.

11 [

1.15.2 PLACING THE VEHICLE ON THE REAR SUPPORT STAND ^{OPT}

NOTE Have the special tool ^{OPT} available:
 – **aprilia** part# 8705021 (rear support stand with appropriate pins).

- ◆ Assemble the pins for the rear support stand, see 1.15.1 (ASSEMBLING THE PINS FOR THE REAR SUPPORT STAND ^{OPT}).

NOTE Have someone help you keep the vehicle in vertical position with the two wheels on the ground.

▲ WARNING

When using the rear support stand, allow the yoke to engage only the pins (1). Do not attempt to support the rear of the vehicle in any other manner.

- ◆ Lift (**Pos. A**) the rear part of the stand (4), insert it from the back of the vehicle and place it so that the two yokes (5) of the support pins (6) hook the two pins (1) provided on the vehicle.

If the yokes (5) do not align with the two pins (1):

- ◆ Loosen the two knobs (7).
- ◆ Slide the two support pins (6) so that the two yokes (5) of the support pins (6) coincide with the two pins (1).
- ◆ Tighten the two knobs (7).
- ◆ Lift (**Pos. A**) the rear part of the stand (4), insert it from the back of the vehicle and place it so that the two yokes (5) of the support pins (6) hook the two pins (1) provided on the vehicle.
- ◆ Rest one foot on the rear part of the stand (4).
- ◆ Push (**Pos. B**) the stand (4) downwards until it reaches the end of its stroke (see figure).

1.15.3 PLACING THE VEHICLE ON THE FRONT SUPPORT STAND ^{OPT}

NOTE Have the special tool ^{OPT} available:
 – **aprilia** part# 8140176 (complete support stand kit).

- ◆ Place the vehicle on the appropriate rear support stand, see 1.15.2 (PLACING THE VEHICLE ON THE REAR SUPPORT STAND ^{OPT}).
- ◆ Lift (**Pos. C**) the front part of the stand (8) and insert each of its ends (9) into holes (10) in the bottom of the front fork.
- ◆ Rest one foot on the front part of the stand (8).
- ◆ Push (**Pos. D**) the stand (8) downwards until it reaches the end of its stroke (see figure).

7 [

6 [

5 [

1 - 34 - 00

3 [

4 [

aprilia Release 00/2001-04

- | | |
|--|---|
| <p>1) Engine model.</p> <p>2) Section.</p> <p>3) Release consecutive number ("00" indicates the first edition).</p> <p>4) Year and month of publication of the Release.</p> <p>5) Section number.</p> <p>6) Section page consecutive number.</p> | <p>7) Updated page consecutive number.</p> <p>8) Chapter title (numbered consecutively).</p> <p>9) Paragraph title (numbered consecutively).</p> <p>10) Description of the operation (always preceded by a rhombus).</p> <p>11) Description of the operation: the star means that the operation must be repeated on the other side of the engine.</p> |
|--|---|

0.3 FOREWORD

This manual contains information covering normal servicing procedures.

In the future, the information and illustrations contained in this manual will be updated by means of "Releases", see 0.1 (UPDATE OF RELEASE 01/2001-12).

Since **aprilia s.p.a.** strives to always improve the quality and usefulness of its engines, changes may be made to the engines at any time.

Thus, it is imperative that users of this manual understand that some information may be out of date for some engines.

Be sure that the information in this manual applies to the engine that you are servicing before you begin any service operations.

Before consulting the manual, check the engine and vehicle model.

This publication is intended for **aprilia** dealers and their trained and qualified mechanics.

The description of many service and repair operations is intentionally omitted, as it is assumed that the users of this manual have basic mechanical training, basic knowledge of the procedures regarding engine and motor vehicle repair, and have available to them all current information published by **aprilia** concerning the engine and vehicle.

Without these things, the repair or servicing of the engine could be affected and could lead to a dangerous condition or accident for the servicing mechanic or the operator.

This manual does not describe all of the procedures necessary to repair and service the engine in detail.

Therefore, it is important to be particularly careful in order to avoid any damage to the engine, its parts, or to cause injury to the mechanic or the rider.

Changes in the technical specifications and servicing procedures that become necessary as a result of changes to **aprilia** engines and vehicles will be documented and distributed to all **aprilia** dealers.

Therefore, it is necessary that the latest **aprilia** information be kept available to the servicing mechanics.

If you have questions regarding repair and servicing procedures, contact the **aprilia** Consumer Service (A.C.S.). A.C.S. technical counselors will be able to assist you with any problems that you might face.

aprilia s.p.a. reserves the right to modify any of its models in any manner at any time.

This manual is protected by copyright in all countries.

Reproduction by any means, print or electronic, is prohibited.

The mention of products or services supplied by entities other than **aprilia** is made for information purposes only.

aprilia is not responsible for the performance or use of any product not specifically recommended or endorsed by **aprilia**.





Produced and printed by:
stp editing division
 Soave (VERONA) - Italy
 tel. +39 045.7611911
 fax +39 045.7612241
 E-mail: customer@stp.it
 www.stp.it

On behalf of:
aprilia s.p.a. Divisione Ricambi
 via Noalese, 156 - 30036 Santa Maria di Sala (VE) - Italia
 tel. +39 041.5786101
 fax +39 041.5786100
 www.aprilia.com
 www.serviceaprilia.com

0.4 REFERENCE **aprilia** SERVICE LITERATURE

For further information, refer to the follows chapter.

0.4.1 VEHICLE WORKSHOP MANUAL

aprilia part# (description)
8140248 (Workshop manual RSV mille  978Y)
8140273 (Workshop manual SL mille  994Y)
8140542 (Workshop manual RST mille Futura  1043-1)
8140548 (Workshop manual ETV mille Caponord  1049-1)

0.4.2 SPARE PARTS CATALOGUE

Consult the corresponding chapter of specific vehicle workshop manual, see 0.4.1 (VEHICLE WORKSHOP MANUAL).

0.4.3 SPECIAL TOOLS CATALOGUE

Consult the corresponding chapter of specific vehicle workshop manual, see 0.4.1 (VEHICLE WORKSHOP MANUAL).

0.4.4 USE AND MAINTENANCE BOOK

Consult the corresponding chapter of specific vehicle workshop manual, see 0.4.1 (VEHICLE WORKSHOP MANUAL).

0.5 ABBREVIATIONS/SYMBOLS/INITIALS

#	= number	kg	= kilograms (1 kg = 2.2046224 lb)
<	= is less than	km	= kilometers (1 km = 0.62137119 mi)
>	= is greater than	km/h	= kilometers an hour
≤	= is equal to or less than	kΩ	= kilohms
≥	= is equal to or greater than	kPa	= kiloPascal (1 kPa = 0.145 psi – 0.01 bar)
~	= approximately	kW	= kilowatt
∞	= infinity	KS	= clutch side (Kupplungseite)
°C	= Celsius degree (centigrade)	ℓ	= liter (1 ℓ = 0.2641721 US gal)
°F	= Fahrenheit degree	LAP	= lap (for competition use)
±	= plus or minus	LED	= Light Emitting Diode
a.c.	= alternating current	m/s	= meters an second
A	= ampere	mbar	= millibar (1 mbar = 0.0145 psi – 0.1 kPa)
Ah	= ampere per hour	MAX	= maximum
API	= American Petroleum Institute	mi	= mile
HV	= high voltage	MIN	= minimum
AV/DC	= AntiVibration Double Countershaft	MPH	= miles per hour
bar	= unit of pressure (1 bar = 14.50 psi – 100 kPa)	MS	= alternator side (Magnetoseite)
BDC	= Bottom Dead Center	MΩ	= megaohm
cm³	= cubic centimeters (1 cm ³ = 0.0338139 US fl oz)	Nm	= newton-meter (1 Nm = 0.723300129 ftlb)
CO	= carbon monoxide	oz	= ounce
CPU	= Central Processing Unit	Ω	= ohm
cu in	= cubic inch	PICK-UP	= pick-up
d.c.	= direct current	PPC	= Pneumatic Power Clutch
DIN	= German industrial normative (Deutsche Industrie Norm)	SAE	= Society of Automotive Engineers
DOHC	= Double Overhead Camshaft	sq in	= square inch
ECU	= Electronic Control Unit	TEST	= diagnostics test
ftlb	= foot pound	TDC	= Top Dead Center
ft	= foot	TSI	= Twin Spark Ignition
g	= gram	US gal	= Usa gallon
rpm	= revolutions per minute	US qt	= USA quart
HC	= unburned hydrocarbons	US fl oz	= USA fluid ounce
in	= inch	UPSIDE-	
ISC	= Idle Speed Control	DOWN	= upside-down fork
ISO	= International Standardization Organization	V	= volt
		W	= watt
		xxxxxxx N.A.	= not available
		∅	= diameter
		Cylinder "1"	= front cylinder
		Cylinder "2"	= rear cylinder

NOTE

THIS PAGE HAS BEEN INTENTIONALLY LEFT EMPTY

GENERAL INFORMATION

1

GENERAL INFORMATION

1 TABLE OF CONTENTS

1.1 INTRODUCTION	1-3-00
1.2 SAFETY WARNINGS	1-3-00
1.3 GENERAL SAFETY RULES	1-4-00
1.3.1 CARBON MONOXIDE	1-4-00
1.3.2 GASOLINE	1-4-00
1.3.3 HOT COMPONENTS	1-4-00
1.3.4 ENGINE OIL	1-4-00
1.3.5 CLUTCH CONTROL FLUID	1-4-00
1.3.6 COOLANT	1-4-00
1.3.7 ENGINE GENERAL SAFETY RULES	1-4-00
1.3.8 PRECAUTIONS AND GENERAL INFORMATION	1-5-00
1.3.9 ELECTRICAL CONNECTORS	1-6-00
1.3.10 FASTENERS TIGHTENING TORQUES ...	1-6-00
1.4 SPECIFIC SAFETY RULES	1-7-00
1.4.1 FUEL	1-7-00
1.4.2 CLUTCH CONTROL FLUID	1-7-00
1.4.3 COOLANT	1-7-00
1.4.4 ENGINE SAFETY RULES	1-8-00
1.4.5 REQUIREMENTS FOR ENGINE OPERATIONS WORK	1-8-00
1.5 HOW TO USE YOUR SERVICE AND REPAIR MANUAL	1-9-00
1.5.1 ADVICE FOR CONSULTATION	1-9-00
1.5.2 ADVICE FOR SPARE PARTS REQUEST	1-9-00

1.1 INTRODUCTION

This manual is divided into sections, chapters and paragraphs, by subject.

The procedures described are laid out in single operation, and each operation is indicated by a ♦.

The numbered parts shown in the figures are identified in the text with the number in parentheses or with the symbol representing them.

Example (the following text is generic and does not refer to this specific engine):

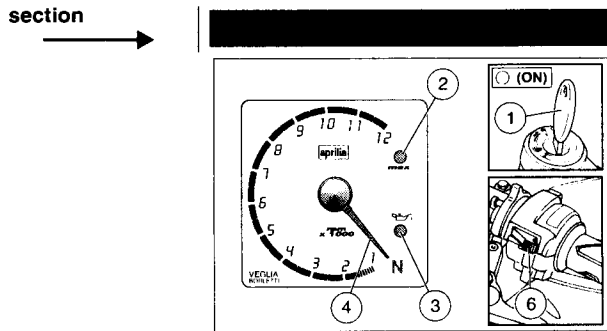

chapter → **2.4 MULTIFUNCTION COMPUTER**

safety warning → **CAUTION**
 After the first 600 mi (1,000 km) and successively every 4,650 mi (7,500 km), the word "SERVICE" appears on the right display.

paragraph → **2.4.1 SEGMENT OPERATION CHECK**

operation → ♦ Rotate the ignition key to position "O" (ON).

position (1) → ♦ The segment (1) will remain on.

symbol "O" → ♦ Rotate the ignition key from position "O" (OFF).

1.2 SAFETY WARNINGS

Throughout this manual, you will see the following symbols:

WARNING

When you find this symbol on the engine or in the manual, this indicates that a potential for serious personal injury or death exists.

Failure to follow this warning may result in serious risk of personal injury or death, of the mechanic working on the engine, the operator of the engine, or the general public.

It also indicates that serious and permanent damage to the engine is possible.

CAUTION

This statement indicates a potential hazard which may result in some personal injury, or damage to the engine.

NOTE The word "NOTE" in this manual precedes important information or instructions to which special attention must be given.

1.3 GENERAL SAFETY RULES

This chapter contains the general safety rules, further and specific safety rules are described in the chapter 1.4 (SPECIFIC SAFETY RULES). Carefully read both these chapters.

The safety rules here described refer to the engine removed from the vehicle frame. For further safety rules refer to the vehicle, consult the corresponding chapter of specific vehicle workshop manual, see 0.4.1 (VEHICLE WORKSHOP MANUAL).

1.3.1 CARBON MONOXIDE

If it is necessary to run the engine in order to carry out a maintenance operation, ensure that the area in which you are operating is properly ventilated.

Never run the engine in enclosed spaces.

If it is necessary to work indoors, use an exhaust evacuation system.

⚠ WARNING

The exhaust fumes contain carbon monoxide, a poisonous gas that can cause loss of consciousness and even death.

1.3.2 GASOLINE

Work in a well ventilated area.

Keep cigarettes, flames or sparks away from the work area and from the place where gasoline is stored.

⚠ WARNING

Gasoline is extremely flammable and becomes explosive under certain conditions.

Use latex gloves for the maintenance operations that require contact with gasoline.

ALWAYS KEEP GASOLINE AWAY FROM CHILDREN AND PETS.

DISPOSE OF UNWANTED, DRAINED OR USED GASOLINE PROPERLY, DO NOT DUMP IT INTO STORM SEWERS OR INTO A SINK OR TOILET.

1.3.3 HOT COMPONENTS**⚠ WARNING**

The engine and the components of the exhaust system become very hot and remain hot for some time after the engine has been stopped.

Before handling these components, wear insulating gloves or wait until the engine and the exhaust system have cooled down.

1.3.4 ENGINE OIL**⚠ WARNING**

Use latex gloves for the maintenance operations that require contact with used oil.

Used oil may cause skin cancer if repeatedly left in contact with the skin for prolonged periods.

Although this is unlikely unless you handle used oil on a daily basis, it is advisable to thoroughly wash your hands with soap and water after handling used oil.

ALWAYS KEEP ENGINE OIL AWAY FROM CHILDREN AND PETS.

DISPOSE OF UNWANTED OR DRAINED ENGINE OIL PROPERLY, DO NOT DUMP IT INTO STORM SEWERS OR INTO A SINK OR TOILET.

1.3.5 CLUTCH CONTROL FLUID**⚠ CAUTION**

The clutch control fluid can damage painted, plastic or rubber parts.

When performing maintenance operations on the clutch control system, place a clean shop towel on these parts, and take care not to spill the clutch control fluid.

Always wear goggles when servicing the clutch control system with clutch control fluid.

Clutch control fluid is extremely destructive to your eyes.

If you should accidentally get clutch control fluid in your eyes, flush immediately with a large quantity of cool clear water and seek professional medical assistance immediately.

Use latex gloves for the maintenance operations that require contact with clutch control fluid.

ALWAYS KEEP CLUTCH CONTROL FLUID AWAY FROM CHILDREN AND PETS.

DISPOSE OF UNWANTED OR DRAINED CLUTCH CONTROL FLUID PROPERLY, DO NOT DUMP IT INTO STORM SEWERS OR INTO A SINK OR TOILET.

1.3.6 COOLANT

In certain conditions, the ethylene glycol contained in the engine coolant is flammable: its flame is invisible, but you can be burned anyway.

⚠ WARNING

Avoid spilling the engine coolant on the exhaust system or on the engine components.

They may be hot enough to cause the coolant to ignite and burn without a visible flame.

The coolant (ethylene glycol) can cause skin irritation and is poisonous if swallowed.

Use latex gloves for the maintenance operations that require contact with coolant.

ALWAYS BE SURE TO KEEP THE COOLANT AWAY FROM CHILDREN AND PETS. IT IS SWEET TASTING, AS WELL AS EXTREMELY POISONOUS, AND IS VERY ATTRACTIVE TO CHILDREN AND PETS.

DISPOSE OF UNWANTED OR DRAINED COOLANT PROPERLY, DO NOT DUMP IT INTO STORM SEWERS OR INTO A SINK OR TOILET.

Do not leave coolant in an open container where pets or other animals may be able to drink it.

1.3.7 ENGINE GENERAL SAFETY RULES**⚠ CAUTION**

Careful adherence to the maintenance operation intervals and the technical documents provided is essential for long life and efficient operation of the engine.

⚠ WARNING

Repair any small problems immediately upon their discovery.

Small problems in the engine will inevitably grow to major problems, which can cause serious irreparable engine damage, and even an accident, with subsequent upset, serious injury, and even death.

Engine seizure will certainly result in a serious accident, and improper maintenance can lead to engine seizure.

If you have any questions about any maintenance operation, do not permit the vehicle to be ridden, and contact the **aprilia** factory immediately.

CAUTION

Maintenance and repair operations carried out on the engine while it is installed in the vehicle must be performed only after turning the engine off and setting the ignition switch to the "⊗" (OFF) position.

Do not attempt to start the engine if all electrical wiring is not completely connected and all ignition and other electrical components are not installed and connected.

CAUTION

Start the engine and let it run **ONLY** for the time necessary for the checking.

WARNING

Exhaust gases contain carbon monoxide, which is extremely poisonous if inhaled. Do not start the engine in closed or badly-ventilated rooms.

Failure to observe this warning may cause loss of consciousness or even lead to death by asphyxia.

WARNING

During maintenance and repair work, observe all general safety rules, and the safety notes provided by **aprilia**.

Pay careful attention and obey all safety rules and suggestions contained in this manual.

Observe all environmental regulations, do not dispose of used engine fluids or defective parts improperly.

1.3.8 PRECAUTIONS AND GENERAL INFORMATION

Follow with care these recommendations when repairing, disassembling and reassembling the engine.

WARNING

The use of open flames is forbidden for any type of operation.

Before commencing any service or inspection operation on the engine wait until the engine has cooled down.

In order to avoid burns, be careful not to touch any parts of the engine which has not cooled down completely.

Avoid the temptation to hold any hardware or other part of the engine in your mouth while working on the engine.

No part of the engine (and vehicle) is edible and some of the coatings, plastics, and platings, etc. are noxious if not outright toxic.

If not expressly described, the reassembly of the units is carried out by reversing the order of operations.

Handle fuel with the greatest caution.

Never use fuel as a solvent for cleaning the engine.

When two or more persons are working together, ensure that each is working in safe condition.

Be sure that all the mechanics working on any one engine are thoroughly briefed as what each will be doing, and insure that one mechanic is responsible for insuring that all safety related items, such as tightening torques, are properly considered.

BEFORE DISASSEMBLY

- Remove any dirt, mud, dust and foreign matter from the engine before disassembling the components.
- Use, when necessary, the special tools designed for this engine.

WARNING

Do not use makeshift tools for any operation which calls for a special tool.

Failure to heed this warning can lead to serious personal injury such as when an ill-fitting wrench slips, and you slam your hand into the workbench or a part of the engine.

DISASSEMBLING THE COMPONENTS

- Before disconnecting any line, cable, etc., mark each part with a number or distinguishing mark. Each disconnected part must be marked clearly in order that it may be reassembled in the same position as it was before disassembly.
- Clean and carefully wash all disassembled parts with fire-proof solvent such as Stoddard solvent or a non-flammable detergent.
- Keep mating parts together, since they have worn in during normal use. There are some sets of parts, such as front sprocket, chain, and rear wheel sprocket, which all must be replaced as a set.
- Be careful not to place plastic or painted parts close to heat sources, where they might be damaged.

REASSEMBLING THE COMPONENTS

CAUTION

Never use a circlip twice. When a circlip is removed, it must be replaced with a new one.

When assembling a new circlip be careful not to stretch its ends more than strictly necessary to place it on the shaft.

After installing a circlip, ensure that it is completely and firmly inserted in its seat.

Do not use compressed air to clean the bearings.

NOTE The bearings must rotate freely, without halting or noise otherwise they must be replaced.

- Use only original **aprilia** SPARE PARTS.
- Use the recommended lubricants.
- Always lubricate parts before reassembly.
- When tightening screws, nuts, and bolts, start with the largest diameter fasteners. When several fasteners are arranged in a pattern, start with the innermost fasteners, and tighten diagonally across the pattern. Tighten each fastener successively before applying the final tightening torque.
- Always replace gaskets, grommets, circlips, O-rings and split pins (cotter pins) with new ones. Before assembling, clean all mating surfaces carefully, removing all traces of the old gasket and gasket sealing compound. Also carefully clean any oil seal you plan to reuse. It is recommended that all oil seals be replaced each time they are disassembled. Gaskets should never be reused. Apply a thin film of lithium based grease to all oil seals before assembling. Install oil seals and bearings with the identification mark or serial number facing outward (visible).

Copiously lubricate bearings before installation and before assembly.

- Ensure that each component has been reassembled correctly.
- After any repair or periodic maintenance operation is carried out, the vehicle must be test ridden in an area away from traffic and other hazards.

1.3.9 ELECTRICAL CONNECTORS

The electrical connectors must be disconnected as follows. Failure to follow these procedures will irreparably damage the connector and wiring.

- ◆ Press in the click tab.

CAUTION

Do not pull the cables to disconnect the two connectors.

- ◆ Grasp the two connectors and disconnect them by pulling in opposite directions.
- ◆ If dirt, rust, dust, or moisture is seen on the connector, blow out the connector with air.
- ◆ Ensure that the cables are correctly crimped to the terminals placed inside the connectors.

NOTE The two halves of the connector fit together properly in only one orientation. Ensure that the connector is properly aligned before attempting to assemble it.

- ◆ Press the connectors firmly together, listening for the typical "click" sound for those connectors provided with a click tab. Ensure that both halves of the connectors are firmly pressed together.

1.3.10 FASTENERS TIGHTENING TORQUES

WARNING

Remember that the tightening torque of all fasteners on the engine is very important to ensure the safety of the engine, and must be kept at the prescribed values.

Check the tightening torque of the fasteners regularly, and always use a torque wrench when reinstalling them.

Failure to comply with this warning could allow one of these components to be lost which could lock a wheel or cause other handling problems with consequent overturning and risk of serious injury or even death.

1.4 SPECIFIC SAFETY RULES

This chapter contains the specific safety rules, further and general safety rules are described in the chapter 1.3 (GENERAL SAFETY RULES). Carefully read both these chapters.

The safety rules here described refer to the engine removed from the vehicle frame. For further safety rules refer to the vehicle, consult the corresponding chapter of specific vehicle workshop manual, see 0.4.1 (VEHICLE WORKSHOP MANUAL).

1.4.1 FUEL

▲ WARNING

Gasoline is extremely flammable and in some conditions can become explosive.

Spilled fuel could ignite when it contacts hot engine or exhaust system surfaces.

Avoid any contact of the fuel with your skin, and avoid inhalation of fuel vapors.

Do not ever attempt to siphon fuel from one container to another using your mouth as suction for a siphon hose.

Gasoline is poisonous and carcinogenic and contains chemical substances that cause birth defects and other reproductive problems.

If gasoline should be accidentally spilled on the skin or clothes, immediately wash it off with soap and water and change clothes.

Should you accidentally spill gasoline in your eyes, flush with a large quantity of water and immediately contact a health professional.

Should you accidentally get gasoline into your mouth, do not induce vomiting. Drink a large quantity of milk or clear water and immediately contact a health professional.

Never try to siphon gasoline by sucking it with your mouth. Use a manual pump or a similar system.

Use latex gloves for the maintenance operations that require contact with gasoline.

ALWAYS KEEP GASOLINE AWAY FROM CHILDREN AND PETS.

DISPOSE OF UNWANTED, DRAINED OR USED GASOLINE PROPERLY, DO NOT DUMP IT INTO STORM SEWERS OR INTO A SINK OR TOILET.

1.4.2 CLUTCH CONTROL FLUID

▲ CAUTION

To avoid serious damage to the system, do not use fluids other than the recommended ones nor mix different fluids.

Do not use clutch fluid taken from old or already opened containers.

1.4.3 COOLANT

▲ WARNING

Coolant is poisonous! Do not ingest coolant under any circumstance.

Should you get coolant in your mouth, rinse with cool water and immediately seek medical attention.

Coolant is also very dangerous to your skin and eyes.

Should you accidentally get coolant on your clothing or skin, change clothes immediately.

Wash coolant from your skin with hot water and soap.

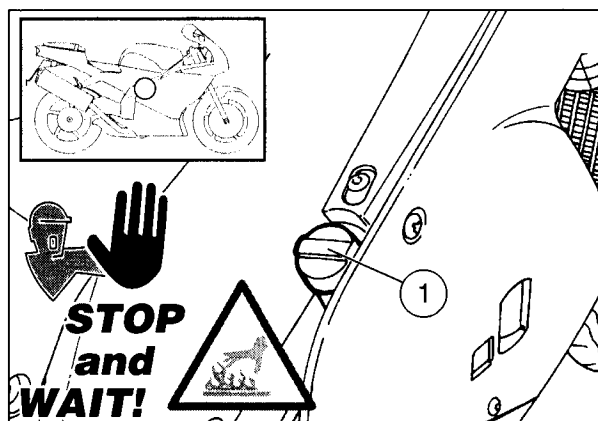

Should you get coolant in your eyes, flush with plenty of cool water and seek professional medical help at once.

Should someone swallow coolant accidentally, induce vomiting, rinse mouth with water, and immediately seek professional medical attention.

Use latex gloves for the maintenance operations that require contact with coolant.

ALWAYS BE SURE TO KEEP THE COOLANT AWAY FROM CHILDREN AND PETS. IT IS SWEET TASTING, AS WELL AS EXTREMELY POISONOUS, AND IS VERY ATTRACTIVE TO CHILDREN AND PETS.

DISPOSE OF UNWANTED OR DRAINED COOLANT PROPERLY, DO NOT DUMP IT INTO STORM SEWERS OR INTO A SINK OR TOILET.

NOTE The characteristics of the various antifreeze liquids are different.

Be sure to read the label on the product to learn the degree of protection it guarantees.

▲ CAUTION

Use only antifreeze and anticorrosive without nitrite in order to ensure protection at at least -35 °C (-95 °F).

1.4.4 ENGINE SAFETY RULES

⚠ WARNING

This **aprilia** engine is designed solely for use this specific **aprilia** vehicle.
Any other use is inappropriate.
Manufacturer will not be liable for any damage which results to the engine or to any other party as a result of this misuse.

⚠ CAUTION

The information contained in this manual is based on **aprilia's** experience with vehicle that have been properly maintained, and are unmodified.
The information in this manual is useful and necessary, but it cannot substitute for proper theoretical and practical training.

⚠ WARNING

Since the **aprilia** engine is built of the highest quality materials, manufactured to exacting tolerances, any spare parts used must meet all of the requirements defined by **aprilia**.
The only spare parts which you can be assured meet these requirements are Genuine **aprilia** Spare Parts and/or accessories, see 0.4.2 (SPARE PARTS CATALOGUE).
The use of spare parts or accessories which do not meet **aprilia's** specifications invalidates the warranty coverage.

⚠ CAUTION

Modifications to the engine and associated system (intake silencer, carburetor, exhaust system, engine fasteners, transmission, etc.) not approved by **aprilia** are likely to degrade the performance and durability of the engine.
Therefore, any such modifications which are found to effect the operation of the engine void the warranty.

1.4.5 REQUIREMENTS FOR ENGINE OPERATIONS WORK

⚠ WARNING

Maintenance of engines and systems requires specific know-how and special tools.
All maintenance and repair work must be performed only by technicians with specific training for **aprilia** engines.
We remind you that parts and equipment that are not Genuine **aprilia** Spare Parts and are not supplied by **aprilia** are neither tested nor approved by **aprilia**. The installation and use of such products can adversely affect the engine's life and performance.
Any damage to the engine caused by the use of such products is not covered under warranty, and **aprilia** will not be responsible for any damage, direct or consequential, as a result of use of such products.
In addition to the advice given in this manual, also observe the general safety and accident prevention regulations and local laws.
During the assembly phase, bear in mind the engine's weight [approx. 143 lb (65 kg)] and center of gravity: support accordingly.

Take care around any potentially hazardous points where you might be squashed or cut.

NOTE Comply with the instructions furnished by the manufacturer of the vehicle.

⚠ WARNING

Engine weight
143 lb
(65 kg)

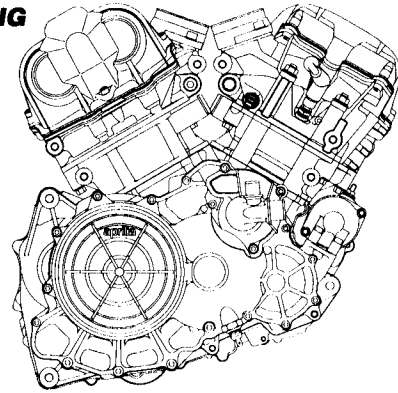
**⚠ WARNING**

Do not use highly inflammable or caustic cleaning agents.

The use of the special tools, fixtures and lubricants specified is required for correct repair.

Never tighten screws and nuts with a pair of pliers: always use the correct wrench.

Use only screws and nuts in good condition. Inspect the contact face and thread for damage, and renew in case of doubt.

Never reuse a self-locking (nylock) nut. Self-locking nuts should always be replaced with new nuts once removed.

Scrupulously observe the tightening torques and upon reassembly of the gasket of the engine renew all sealing.
Never reuse these parts.

Overtightening or loose connections may cause serious engine damage.

Upon reassembly of the engine, renew all sealing rings, gaskets, snap rings, O-rings and oil seals removed.

Use only the securing agents, sealing and adhesive compounds, lubricants, cleaning agents and solvents specified in the corresponding chapter.
Non-compliance can lead to damage.

Clean and check the parts removed before re-use and refit them according to the instructions.

Check for missing or defective parts prior to reassembly.

After reassembly, check all components for tight fit and flawless operation.

1.5 HOW TO USE YOUR SERVICE AND REPAIR MANUAL

1.5.1 ADVICE FOR CONSULTATION

This manual is divided into sections, chapters and paragraphs, each one of which corresponds to a category of main components.

If not expressly indicated otherwise, for the reassembly of the units repeat the disassembly operations in reverse order.

The terms "right" and "left" are referred to the engine mounted on the vehicle in the normal riding position.

For normal maintenance operations and for the use of the vehicle, consult the specific use and maintenance book, see 0.4.4 (USE AND MAINTENANCE BOOK).

For further maintenance operations consult the specific vehicle workshop manual, see 0.4.1 (VEHICLE WORKSHOP MANUAL).

- ★ The operations preceded by this symbol must be repeated on the opposite side of the engine.

1.5.2 ADVICE FOR SPARE PARTS REQUEST

NOTE When asking your Dealer for spare parts, specify:

- the spare parts code indicated on the SPARE PARTS IDENTIFICATION LABEL (see the figure);
- the frame number, see 2.1.1 (FRAME NUMBER);
- all the other data request in the instructions contained in the specific spare parts catalogue, see 0.4.2 (SPARE PARTS CATALOGUE).

aprilia		N° 390Y		YEAR		T	V	W	X	Y
SPARE P ARTS		CODE NUMBER		I.M.		A	B	C	D	E
I	UK	A	P	SF	B	D	F	E	GR	
NL	CH	DK	J	SGP	PL	IL	ROK	MAL	RCH	
BM	AUS	USA	BR	RSA	NZ	CDN	HR	SLO		

This label is placed on the vehicle, to know its position consult the corresponding chapter of specific vehicle workshop manual, see 0.4.1 (VEHICLE WORKSHOP MANUAL) or the specific use and maintenance book, see 0.4.4 (USE AND MAINTENANCE BOOK).

In this manual the various versions are indicated by the following symbols:

- catalytic version
- EES** evaporative emission system
- OPT** optional
- RSV** RSV mille
- RSV R** RSV mille R
- SL** SL mille
- RST** RST mille Futura
- ETV** ETV mille Caponord

VERSION:

- I** Italy
- UK** United Kingdom
- A** Austria
- P** Portugal
- SF** Finland
- B** Belgium
- D** Germany
- F** France
- E** Spain
- GR** Greece
- NL** Holland
- CH** Switzerland
- DK** Denmark
- J** Japan
- SGP** Singapore
- PL** Poland
- IL** Israel
- ROK** South Korea
- MAL** Malaysia
- RCH** Chile
- BM** Bermuda
- USA** United States of America
- AUS** Australia
- BR** Brazil
- RSA** South Africa
- NZ** New Zealand
- CDN** Canada
- HR** Croatia
- SLO** Slovenia

NOTE

Lined area for notes, consisting of approximately 30 horizontal lines.

THIS PAGE HAS BEEN INTENTIONALLY LEFT EMPTY





TECHNICAL INFORMATION

2

TECHNICAL INFORMATION

2

TABLE OF CONTENTS

2.1 IDENTIFICATION DATA 2-3-00
 2.1.1 FRAME NUMBER 2-3-00
 2.1.2 ENGINE NUMBER 2-3-00
2.2 REGULAR SERVICE
INTERVAL CHART 2-3-00
2.3 SPARE PARTS 2-4-00
2.4 TECHNICAL DATA 2-4-00
2.5 LUBRICANT CHART 2-6-00
2.6 CONSUMABLES 2-7-00
 2.6.1 PRODUCT PROPERTIES 2-7-00
 2.6.2 USE OF CONSUMABLES 2-8-00
2.7 SPECIAL TOOLS  2-10-00
 2.7.1 ENGINE TOOLS  2-10-00
 2.7.2 MISCELLANEOUS TOOLS  2-12-00
 2.7.3 FURTHER
 aprilia VEHICLES TOOLS  2-13-00
2.8 FASTENERS 2-14-00
 2.8.1 JOINTS WITH CLICK CLAMPS
 AND WITH SCREW-TYPE CLAMPS 2-14-00
 2.8.2 GENERAL VALUES
 OF TIGHTENING TORQUES 2-15-00
 2.8.3 SPECIFIC VALUES
 OF TIGHTENING TORQUES 2-16-00

V990 engine 

2.1 IDENTIFICATION DATA

Please supply the frame number when you purchase spare parts.

NOTE Do not obliterate or alter the identification numbers under any circumstance.

This is illegal in all countries.

In addition, alteration of the identification numbers invalidates the warranty.

2.1.1 FRAME NUMBER

Consult the corresponding paragraph of specific vehicle workshop manual, see 0.4.1 (VEHICLE WORKSHOP MANUAL).

2.1.2 ENGINE NUMBER

The engine number (1) is stamped on the rear part of the left engine crankcase.

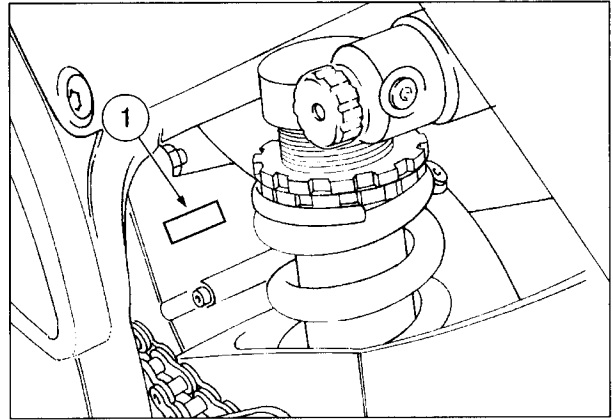

2.2 REGULAR SERVICE INTERVAL CHART

Consult the corresponding chapter in the section 2 (SERVICE AND SETTING UP) of specific vehicle workshop manual, see 0.4.1 (VEHICLE WORKSHOP MANUAL).

2.3 SPARE PARTS

For any replacement, use **aprilia** Genuine Spare Parts only.
aprilia Genuine Spare Parts are high-quality parts, expressly designed and manufactured for **aprilia** vehicles.























CAUTION

Failure to use **aprilia Genuine Spare Parts may result in poor performance and damage to your vehicle.**

2.4 TECHNICAL DATA

DIMENSIONS

For this technical data consult the corresponding voice in the chapter (TECHNICAL DATA) of specific vehicle workshop manual, see 0.4.1 (VEHICLE WORKSHOP MANUAL).

ENGINE	
Model	V990
Type	60° longitudinal V-type, two-cylinder, 4-stroke, with 4 valves per cylinder, DOHC.
Number of cylinders	2
Total displacement  (vehicles up to year 2000)	60.88 cu in (997.60 cm ³)
Total displacement  (vehicles year 2001 and later)	60.90 cu in (998.00 cm ³)
Total displacement  (vehicles up to year 2000)	60.88 cu in (997.60 cm ³)
Total displacement  (vehicles year 2001 and later)	60.90 cu in (998.00 cm ³)
Total displacement 	60.88 cu in (997.62 cm ³)
Total displacement 	60.90 cu in (998.00 cm ³)
Max. rated power (to crankshaft)	86.5 kW (116 HP) at 9,250 rpm
Max. torque	67.3 ftlb (93 Nm) at 7,000 rpm
Bore/stroke	3.82 in/2.66 in (97.00 mm/67.50 mm)
Compression ratio  (vehicles up to year 2000)	11.4 ± 0.5 : 1
Compression ratio  (vehicles year 2001 and later)	11.8 ± 0.5 : 1
Compression ratio  (vehicles up to year 2000)	11.4 ± 0.5 : 1
Compression ratio  (vehicles year 2001 and later)	11.8 ± 0.5 : 1
Compression ratio 	11.8 ± 0.5 : 1
Compression ratio 	10.4 ± 0.5 : 1
Average piston speed	22.5 m/s at 10000 rpm
Camshaft during intake stroke  (vehicles up to year 2000)	262°, valve lifting: 0.42 in (10.60 mm)
Camshaft during exhaust stroke  (vehicles up to year 2000)	259°, valve lifting: 0.42 in (10.60 mm)
Camshaft during intake stroke  (vehicles year 2001 and later)	262°, valve lifting: 0.45 in (11.40 mm)
Camshaft during exhaust stroke  (vehicles year 2001 and later)	259°, valve lifting: 0.42 in (10.60 mm)
Camshaft during intake stroke  (vehicles up to year 2000)	262°, valve lifting: 0.42 in (10.60 mm)
Camshaft during exhaust stroke  (vehicles up to year 2000)	259°, valve lifting: 0.42 in (10.60 mm)
Camshaft during intake stroke  (vehicles year 2001 and later)	262°, valve lifting: 0.45 in (11.40 mm)
Camshaft during exhaust stroke  (vehicles year 2001 and later)	259°, valve lifting: 0.42 in (10.60 mm)
Camshaft during intake stroke 	259°, valve lifting: 0.42 in (10.60 mm)
Camshaft during exhaust stroke 	259°, valve lifting: 0.42 in (10.60 mm)
Camshaft during intake stroke 	242°, valve lifting: 0.37 in (9.50 mm)

Follow ►

Follow ►

ENGINE	
Camshaft during exhaust stroke ETV	242°, valve lifting: 0.37 in (9.50 mm)
Valve advance (with valve clearance 1 mm) RSV RSV R	<ul style="list-style-type: none"> - opening during intake stroke: 20° before TDC - closing during intake stroke: 62° after BDC - opening during exhaust stroke: 64° before TDC - closing during exhaust stroke: 15° after BDC
Valve advance (with valve clearance 1 mm) SL	<ul style="list-style-type: none"> - opening during intake stroke: 20° before TDC - closing during intake stroke: 62° after BDC - opening during exhaust stroke: 64° before TDC - closing during exhaust stroke: 15° after BDC
Valve advance (with valve clearance 1 mm) RST	<ul style="list-style-type: none"> - opening during intake stroke: 20° before TDC - closing during intake stroke: 59° after BDC - opening during exhaust stroke: 64° before TDC - closing during exhaust stroke: 15° after BDC
Valve advance (with valve clearance 1 mm) ETV	<ul style="list-style-type: none"> - opening during intake stroke: 25° before TDC - closing during intake stroke: 37° after BDC - opening during exhaust stroke: 57° before TDC - closing during exhaust stroke: 5° after BDC
Valve clearance (with engine cold)	0.005 – 0.006 in (0.12 – 0.17 mm) [intake] - 0.009 – 0.011 in (0.23 – 0.28 mm) [exhaust]
Diameter of the inlet valve plate RSV RSV R (vehicles up to year 2000)	1.42 in (36.0 mm)
Diameter of the exhaust valve plate RSV RSV R (vehicles up to year 2000)	1.22 in (31.0 mm)
Diameter of the inlet valve plate RSV RSV R (vehicles year 2001 and later)	1.50 in (38.0 mm)
Diameter of the exhaust valve plate RSV RSV R (vehicles year 2001 and later)	1.22 in (31.0 mm)
Diameter of the inlet valve plate SL (vehicles up to year 2000)	1.42 in (36.0 mm)
Diameter of the exhaust valve plate SL (vehicles up to year 2000)	1.22 in (31.0 mm)
Diameter of the inlet valve plate SL (vehicles year 2001 and later)	1.50 in (38.0 mm)
Diameter of the exhaust valve plate SL (vehicles year 2001 and later)	1.22 in (31.0 mm)
Diameter of the inlet valve plate RST	1.42 in (36.0 mm)
Diameter of the exhaust valve plate RST	1.22 in (31.0 mm)
Diameter of the inlet valve plate ETV	1.42 in (36.0 mm)
Diameter of the exhaust valve plate ETV	1.22 in (31.0 mm)
Engine idling rpm RSV RSV R	1,250 ± 100 rpm CO 1% [+1% – 0.5% (total range from 0.5% to 2%)]
Engine idling rpm SL	1,250 ± 100 rpm CO 1% [+1% – 0.5% (total range from 0.5% to 2%)]
Engine idling rpm RST	1,250 ± 100 rpm CO 1% [+1% – 0.5% (total range from 0.5% to 2%)]
Engine idling rpm ETV	1,340 ± 100 rpm CO 1% [+1% – 0.5% (total range from 0.5% to 2%)]
Engine revolutions at peak rpm RSV RSV R (vehicles up to year 2000)	10,250 ± 100 rpm
Engine revolutions at peak rpm RSV RSV R (vehicles year 2001 and later)	10,500 ± 100 rpm
Engine revolutions at peak rpm SL (vehicles up to year 2000)	10,250 ± 100 rpm

Follow ►

Follow ►

ENGINE	
Engine revolutions at peak rpm SL (vehicles year 2001 and later)	10,500 ± 100 rpm
Engine revolutions at peak rpm RST	10,500 ± 100 rpm
Engine revolutions at peak rpm ETV	8,750 ± 100 rpm
Ignition	electronically controlled
Ignition timing	21.8° ± 2° at 2,800 rpm
Starting	electric
Spark advance	At start: 5° before TDC, additional advance depending on specific consumption levels
Starter motor gear ratio	$i = 49/9 * 30/11 * 64/30 = 31.677$
Clutch	multidisc in oil bath, with hydraulic control on the left side of the handlebar and PPC device - # 9 lined discs; thick 0.14 in (3.5 mm) - # 10 internal discs; thick 0.06 in (1.5 mm)
Gear	mechanical, 6 gears with foot control on the left side of the engine
Lubrication system	dry pan with separate oil tank, 2 trochoidal pumps and cooling radiator
Lubrication pressure	min 72.5 in (500 kP) (5 bar) at max 80 °C (176 °F) and 6,000 rpm
Air cleaner	with dry filter cartridge
Cooling	liquid-cooled
Coolant pump gear ratio	$i_{wp} = 28/27 * 28/28 = 1.037$
Coolant pump delivery (with thermal expansion valve open)	23.8 Us gal/min (90 ℓ/min) and 9,000 rpm
Thermal expansion valve opening start temperature	65 ± 2 °C (149 ± 5 °F)
Engine dry weight	~ 143 lb (65 kg)

CAPACITY	
Engine oil	oil renew 3.91 US qt (3,700 cm³) – oil and oil filter renew 4.12 US qt (3,900 cm³)
For further technical data consult the corresponding voice in the chapter (TECHNICAL DATA) of specific vehicle workshop manual, see 0.4.1 (VEHICLE WORKSHOP MANUAL).	

DRIVE BSV BSV B					
GEAR RATIOS	Ratio	Primary	Secondary	Final ratio	Total ratio
	1 st	31/60 = 1 : 1.935	14/35 = 1 : 2.500	17/42 = 1 : 2.470	11.948
	2 nd		16/28 = 1 : 1.750		8.368
	3 rd		19/26 = 1 : 1.368		6.543
	4 th		22/24 = 1 : 1.091		5.216
	5 th		23/22 = 1 : 0.957		4.573
	6 th		27/23 = 1 : 0.852		4.073
For further technical data consult the corresponding voice in the chapter (TECHNICAL DATA) of specific vehicle workshop manual, see 0.4.1 (VEHICLE WORKSHOP MANUAL).					

Follow ►

Follow ►

DRIVE SL					
GEAR RATIOS	Ratio	Primary	Secondary	Final ratio	Total ratio
	1 st	31/60 = 1 : 1.935	14/35 = 1 : 2.500	16/41 = 1 : 2.563	12.399
	2 nd		16/28 = 1 : 1.750		8.679
	3 rd		19/26 = 1 : 1.368		6.787
	4 th		22/24 = 1 : 1.091		5.411
	5 th		23/22 = 1 : 0.957		4.744
	6 th		27/23 = 1 : 0.852		4.225

For further technical data consult the corresponding voice in the chapter (TECHNICAL DATA) of specific vehicle workshop manual, see 0.4.1 (VEHICLE WORKSHOP MANUAL).

DRIVE RST					
GEAR RATIOS	Ratio	Primary	Secondary	Final ratio	Total ratio
	1 st	31/60 = 1 : 1.935	14/35 = 1 : 2.500	16/43 = 1 : 2.687	13.000
	2 nd		16/28 = 1 : 1.750		9.102
	3 rd		19/26 = 1 : 1.368		7.117
	4 th		22/24 = 1 : 1.091		5.674
	5 th		23/22 = 1 : 0.957		4.975
	6 th		27/23 = 1 : 0.852		4.431

For further technical data consult the corresponding voice in the chapter (TECHNICAL DATA) of specific vehicle workshop manual, see 0.4.1 (VEHICLE WORKSHOP MANUAL).

DRIVE DIV					
GEAR RATIOS	Ratio	Primary	Secondary	Final ratio	Total ratio
	1 st	31/60 = 1 : 1.935	14/35 = 1 : 2.500	17/45 = 1 : 2.647	12.804
	2 nd		16/28 = 1 : 1.750		9.041
	3 rd		19/26 = 1 : 1.368		7.006
	4 th		22/24 = 1 : 1.091		5.582
	5 th		23/22 = 1 : 0.957		4.896
	6 th		27/23 = 1 : 0.852		4.358

For further technical data consult the corresponding voice in the chapter (TECHNICAL DATA) of specific vehicle workshop manual, see 0.4.1 (VEHICLE WORKSHOP MANUAL).

FUEL SYSTEM
For this technical data consult the corresponding voice in the chapter (TECHNICAL DATA) of specific vehicle workshop manual, see 0.4.1 (VEHICLE WORKSHOP MANUAL).

FRAME
For this technical data consult the corresponding voice in the chapter (TECHNICAL DATA) of specific vehicle workshop manual, see 0.4.1 (VEHICLE WORKSHOP MANUAL).

SUSPENSIONS
For this technical data consult the corresponding voice in the chapter (TECHNICAL DATA) of specific vehicle workshop manual, see 0.4.1 (VEHICLE WORKSHOP MANUAL).

Follow ►

Follow ►

BRAKES

For this technical data consult the corresponding voice in the chapter (TECHNICAL DATA) of specific vehicle workshop manual, see 0.4.1 (VEHICLE WORKSHOP MANUAL).

WHEEL RIMS

For this technical data consult the corresponding voice in the chapter (TECHNICAL DATA) of specific vehicle workshop manual, see 0.4.1 (VEHICLE WORKSHOP MANUAL).

FRONT TIRE

For this technical data consult the corresponding voice in the chapter (TECHNICAL DATA) of specific vehicle workshop manual, see 0.4.1 (VEHICLE WORKSHOP MANUAL).

REAR TIRE

For this technical data consult the corresponding voice in the chapter (TECHNICAL DATA) of specific vehicle workshop manual, see 0.4.1 (VEHICLE WORKSHOP MANUAL).

SPARK PLUGS

Number per cylinder	2
Standard	NGK R DCPR9E
Spark plug gap	0.024 – 0.028 in (0.6 – 0.7 mm)
Resistance	5 kΩ

ELECTRIC SYSTEM

For this technical data consult the corresponding voice in the chapter (TECHNICAL DATA) of specific vehicle workshop manual, see 0.4.1 (VEHICLE WORKSHOP MANUAL).

BULBS

For this technical data consult the corresponding voice in the chapter (TECHNICAL DATA) of specific vehicle workshop manual, see 0.4.1 (VEHICLE WORKSHOP MANUAL).

WARNING LIGHTS

For this technical data consult the corresponding voice in the chapter (TECHNICAL DATA) of specific vehicle workshop manual, see 0.4.1 (VEHICLE WORKSHOP MANUAL).

2.5 LUBRICANT CHART









Consult the corresponding chapter of specific vehicle workshop manual, see 0.4.1 (VEHICLE WORKSHOP MANUAL) or the specific use and maintenance book, see 0.4.4 (USE AND MAINTENANCE BOOK).

2.6 CONSUMABLES

Only use the products given below for any maintenance work. The materials mentioned have been tested for many years and are suitable for all the application conditions indicated by the manufacturer.

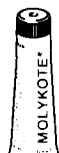

NOTE The consumables, which are coded, are available on application, see 2.6.2 (USE OF CONSUMABLES).

2.6.1 PRODUCT PROPERTIES

aprilia part# (product)	Use and properties
- aprilia part# 0897651 [LOCTITE® 243 blue 0.34 fl oz (10 cm ³)] 	Thread locker for screws and nuts up to M36, and to seal connections for fluids, medium strength. It can be used on parts which have not been completely degreased. The hardening time depends on the temperature and the material (maximum one hour). Resistance to temperatures in the range -55 to 150 °C (-131 °F to 302 °F).
- aprilia part# 0898011 (fluorescent green LOCTITE® 275). 	It prevents the loosening of the threaded components and the fluid leakages due to vibrations. It must be used on clean, degreased and non-oxidized components. Apply a quantity sufficient to cover all the threaded part.
- aprilia part# 0899788 [LOCTITE® 648 green 0.17 oz (5 g)] 	High strength thread locker for screw threads. The hardening time depends on the temperature and the material (maximum twelve hours). Resistance to temperatures in the range -55 to 175 °C (-131 °F to 347 °F). To remove nuts that have been fastened with Loctite 648, it may be necessary to heat the assembled parts to a temperature of 250 °C (482 °F).
- aprilia part# 0899784 (LOCTITE® 574 orange) 	Solvent-free joint cement, to be used instead of gaskets where components are held firmly together, and where a precise distance is required between the two components. Applied in its liquid state, it hardens after assembly on contact with the metal within a few hours. A seal is created whose surface structure adapts to the surfaces to be sealed. Resistance to temperatures in the range -55 to 200 °C (-131 °F to 392 °F); where applied, it seals the surfaces against corrosion.
- aprilia part# 8116067 (LOCTITE® 8150) 	Paste to be used on components subjected to high temperature.
- aprilia part# 0297434 (LOCTITE® 767 Anti Seize 15378) 	Lubricant and anti-corrosive, resistant to high temperatures. Sprayed on both components, it ensures low sliding friction and maintenance-free operation for a long period. It also prevents corrosion.
- aprilia part# 0297433 [MOLYKOTE® G-N 1.76 oz (50 g)] 	Lubricating grease, used on connections and bearings subject to heavy loads, and to lubricate threads and connections which are heavily torqued, in order to prevent corrosion, which would prevent subsequent disassembly. To be applied to both joining surfaces.
- aprilia part# 0297386 [SILASTIC 732 RTV 3.53 oz (100 g)] 	Silicone rubber sealant, used to prevent water from getting inside the alternator cover.

2.6.2 USE OF CONSUMABLES

For the description of use unintentionally omitted in these tables, and for further information refer to the use of consumables, see 0.4.2 (SPARE PARTS CATALOGUE).



aprilia part# (product)	Description of use
– aprilia part# 8116050 (engine oil) (*)	<ul style="list-style-type: none"> – On timing intermediate gear roller bearings. – On lower balanceshaft thrust washer. – Clutch disengaging shaft. – On valve stems and valve lifter buckets. – On valve guide oil seals. – On camshaft housings. – On the timing chain tightener. – On double starter gear and idler gear pins. – On the sprag clutch gear/sprag clutch contact surface. – On the sprag clutch inner contact surface. – On piston, piston rings and piston rings grooves. <p>For the description of use referred to vehicle components consult the corresponding voice in the chapter (USE OF CONSUMABLES) of specific vehicle workshop manual, see 0.4.1 (VEHICLE WORKSHOP MANUAL).</p>
– aprilia part# 0897651 [LOCTITE® 243 blue 0.34 fl oz (10 cm³)] (**)	<ul style="list-style-type: none"> – On coolant pump center fastening screw. – On cylinder joining bracket fastening screws. – On engine half-case bearing lock screws. – On cylinder fastening stud bolts (engine half-case side). –  On crankshaft position sensor fastening screws. – On camshaft position sensor fastening screws. –  On crankshaft position sensor fastening screw. – On index lever and plate fastening screws. – On crankshaft fastening nut. – On timing gear fastening screws. – On upper balanceshaft balanceweight fastening nut. – On intermediate timing gear bearing support lower fastening screw. – On thread of coolant manifold plug, on rear cylinder “2”. – On thread of engine oil pressure sensor. – On stator fastening screws. <p>For the description of use referred to vehicle components consult the corresponding voice in the chapter (USE OF CONSUMABLES) of specific vehicle workshop manual, see 0.4.1 (VEHICLE WORKSHOP MANUAL).</p>
– aprilia part# 0898011 (fluorescent green LOCTITE® 275) (**) 	<ul style="list-style-type: none"> – On thread of coolant union coupling, on cylinders.
– aprilia part# 0899784 (LOCTITE® 574 orange) (**) 	<ul style="list-style-type: none"> – On neutral gear switch contact screw. – On both surfaces of the engine oil pump. – On cylinder base where it contacts the engine case. – On thread of the engine oil union coupling, on the rear cylinder “2”. <p>For the description of use referred to vehicle components consult the corresponding voice in the chapter (USE OF CONSUMABLES) of specific vehicle workshop manual, see 0.4.1 (VEHICLE WORKSHOP MANUAL).</p>

(*) = see 2.5 (LUBRICANT CHART).

(**) = see 2.6.1 (PRODUCT PROPERTIES).

Follow 

Follow ►

aprilia part# (product)	Description of use
– aprilia part# 0899788 [LOCTITE® 648 green 0.17 oz (5 g)] (**)	<ul style="list-style-type: none"> – On coolant pump idler gear pin. – On engine oil pump cap. – On spring-support plate/clutch gear/clutch housing fastening screws. – On clutch gear metal slip fastening screws. – Assembly sprag clutch flange/alternator rotor. – On clutch housing fastening nut. – On lower balancershaft balanceweight fastening screw. – On sprag clutch flange/alternator rotor fastening screws. – On alternator rotor inner taper. – On flywheel fastening screw. – On the flat surface of the sprag clutch flange before to place it in the center of the alternator rotor. – On thread (side cylinder) of exhaust pipes studs.
– aprilia part# 8116067 (LOCTITE® 8150) (**)	<p>For the description of use referred to vehicle components consult the corresponding voice in the chapter (USE OF CONSUMABLES) of specific vehicle workshop manual, see 0.4.1 (VEHICLE WORKSHOP MANUAL).</p>
– aprilia part# 0897330 (multi-purpose grease bp lz.)	<ul style="list-style-type: none"> – On the thrust washer of the oil pump intermediate drive gear. – On the oil seal of the upper balancershaft bearing. <p>For the description of use referred to vehicle components consult the corresponding voice in the chapter (USE OF CONSUMABLES) of specific vehicle workshop manual, see 0.4.1 (VEHICLE WORKSHOP MANUAL).</p>
– aprilia part# 0297434 (LOCTITE® 767 Anti Seize 15378) (**)	<ul style="list-style-type: none"> – On main shaft and countershaft. – On main shaft and countershaft housings. – On crankshaft and lower balancershaft. – On the main shaft housing and spline.
– aprilia part# 0297433 [MOLYKOTE® G-N 1.76 oz (50 g)] (**)	<ul style="list-style-type: none"> – On main bushing housings. – On main bushings. – On engine case bearing housings. – On coolant pump shaft. – On valve guide recesses in the head. – On valve guide edges. – Valve lifter buckets/camshaft cams contact surface. – On crankshaft and lower balancershaft bushing housings. – On crankshaft and lower balancershaft housings. – On connecting rod/piston pin bores. – On camshafts cams. – On starter motor fastening housing.
– aprilia part# 0297386 [SILASTIC 732 RTV 3.53 oz (100 g)] (**)	<ul style="list-style-type: none"> – On cable bracket on alternator cover. – On camshaft sensor cable guide. –  On contact surfaces of plastic plug with the front cylinder "1".
– aprilia part# 8116053  Bimol Grease 481)	<ul style="list-style-type: none"> – On intermediate timing gear thrust washer. – Lower balancershaft oil seal. – Starter motor gear. <p>For the description of use referred to vehicle components consult the corresponding voice in the chapter (USE OF CONSUMABLES) of specific vehicle workshop manual, see 0.4.1 (VEHICLE WORKSHOP MANUAL).</p>

(**) = see 2.6.1 (PRODUCT PROPERTIES).

2.7 SPECIAL TOOLS OPT

In order to perform assembly, reassembly and settings correctly, special tools suitable for the task must be used. The use of special tools avoids the potential risk of damage as a result of inappropriate tools and/or improvised methods.

Below is a list of the special tools designed especially for this specific engine.

When ordering generic special tools, refer to the special tools manual.

CAUTION
Before using the special tools, consult any documents attached.

WARNING
Do not attempt to use makeshift tools to work on this engine. To do so will not only ensure that you damage the engine, sometimes irreparably, but you will also hurt yourself. Failure to use special tools will certainly lead to injury to the mechanic.

2.7.1 ENGINE TOOLS OPT

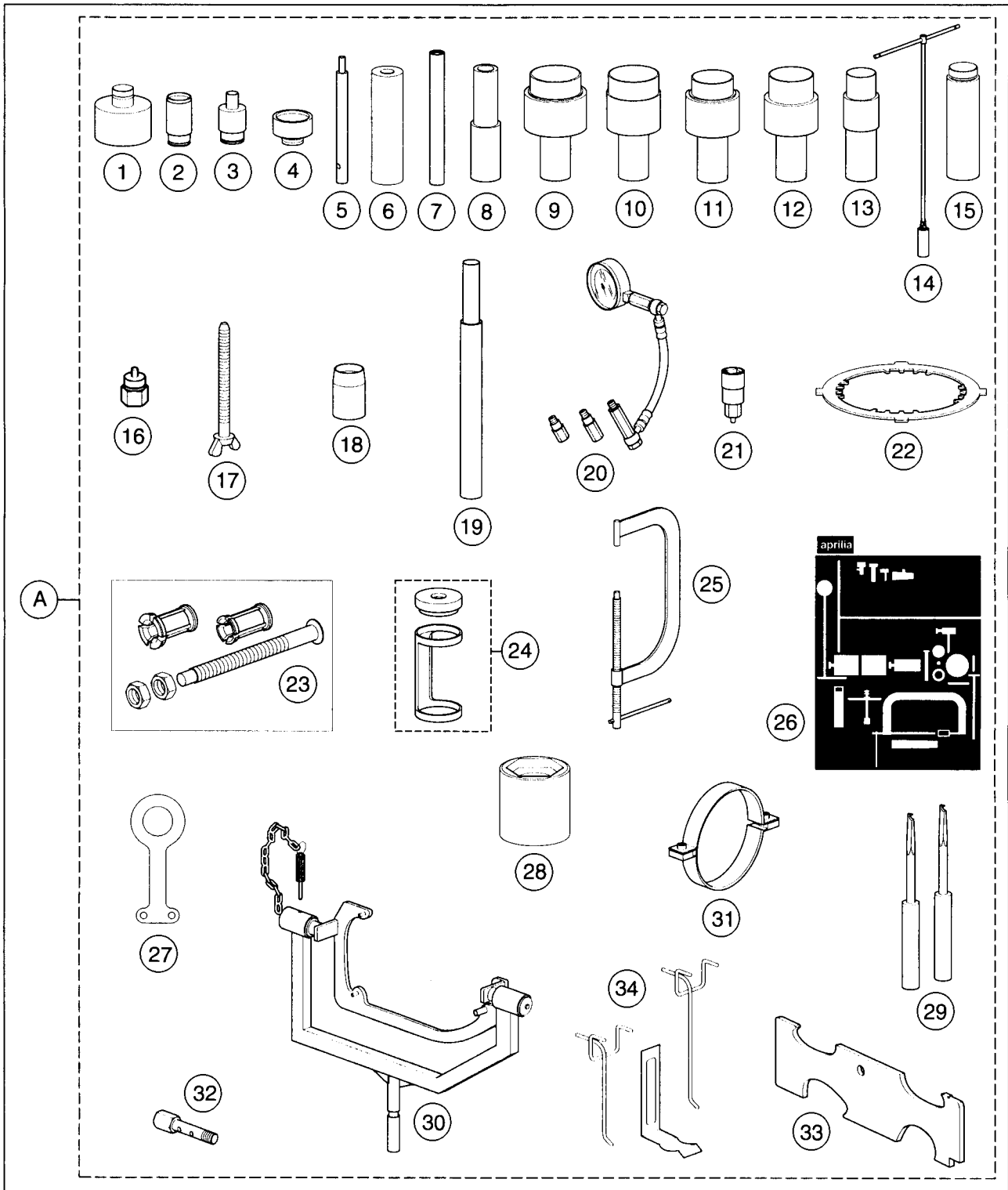

Follow ►

Follow ►

Pos.	– aprilia part# (tool description and function)	Note
A	– 8140175 (complete tool kit for engine)	–
1	– 0277680 (countershaft oil seal assembly drift)	✕
2	– 0277660 (upper balanceshaft oil seal assembly drift)	✕
3	– 0277670 (coolant pump shaft housing oil seal assembly drift)	✕
4	– 0877257 (coolant pump shaft housing sliding ring assembly drift)	✕
5	– 0277510 (valve guide disassembly drift)	✕
6	– 0277210 (valve guide assembly drift)	✕
7	– 0277695 (valve guide oil seal assembly drift)	✕
8	– 8140155 (main shaft oil seal-clutch shaft oil seal assembly drift)	✕
9	– 0277725 (crankshaft bushing inserter drift)	✕
10	– 0277720 (crankshaft sleeve puller drift)	✕
11	– 0277537 (upper balanceshaft bushing inserter drift)	✕
12	– 0277727 (crankshaft-clutch cover bushing inserter drift)	✕
13	– 0277729 (lower balanceshaft bushing inserter drift)	✕
14	– 8140177 (cap socket spanner)	●
15	– 0277252 (tool for removal alternator cover)	✕
16	– 0277730 (alternator rotor removal hexagonal bolt)	✕
17	– 0240880 (threaded bolt for retaining the crankshaft at TDC)	✕
18	– 0277308 (countershaft guide bushing)	✕
19	– 8140178 (piston pin disassembly and reassembly drift)	✕
20	– 8140181 (fuel-oil pressure gauge)	●
21	– 8140182 (alternator rotor bolt removal bushing)	✕
22	– 0277881 (clutch locking tool)	✕
23	– 8140156 + 8140157 + 0276377 (clutch cover sleeve puller)	✕
24	– 0276479 (valves spring-pusher tool)	✕
25	– 8140179 (valves disassembly and reassembly clamp)	✕
26	– 8157143 (adhesive for tool holder panel)	–
27	– 8140183 (engine lifting eye hook)	●
28	– 8140184 (primary transmission nut disassembly bushing)	✕
29	– 8140185 (clutch disc extraction hook lever)	✕
30	– 8140188 (engine support)	●
31	– 8140186 (piston ring compression tool)	✕
32	– 8140197 (banjo screw for fuel pressure test)	●
33	– 8140205 (camshaft template tool)	✕
34	– 8140426 (panel hooks)	–

✕ = Special tools required in order to perform some operations described in this manual.

● = Special tools required to perform some operations described in the specific vehicle workshop manual, see 0.4.1 (VEHICLE WORKSHOP MANUAL).

2.7.2 MISCELLANEOUS TOOLS **OPT**

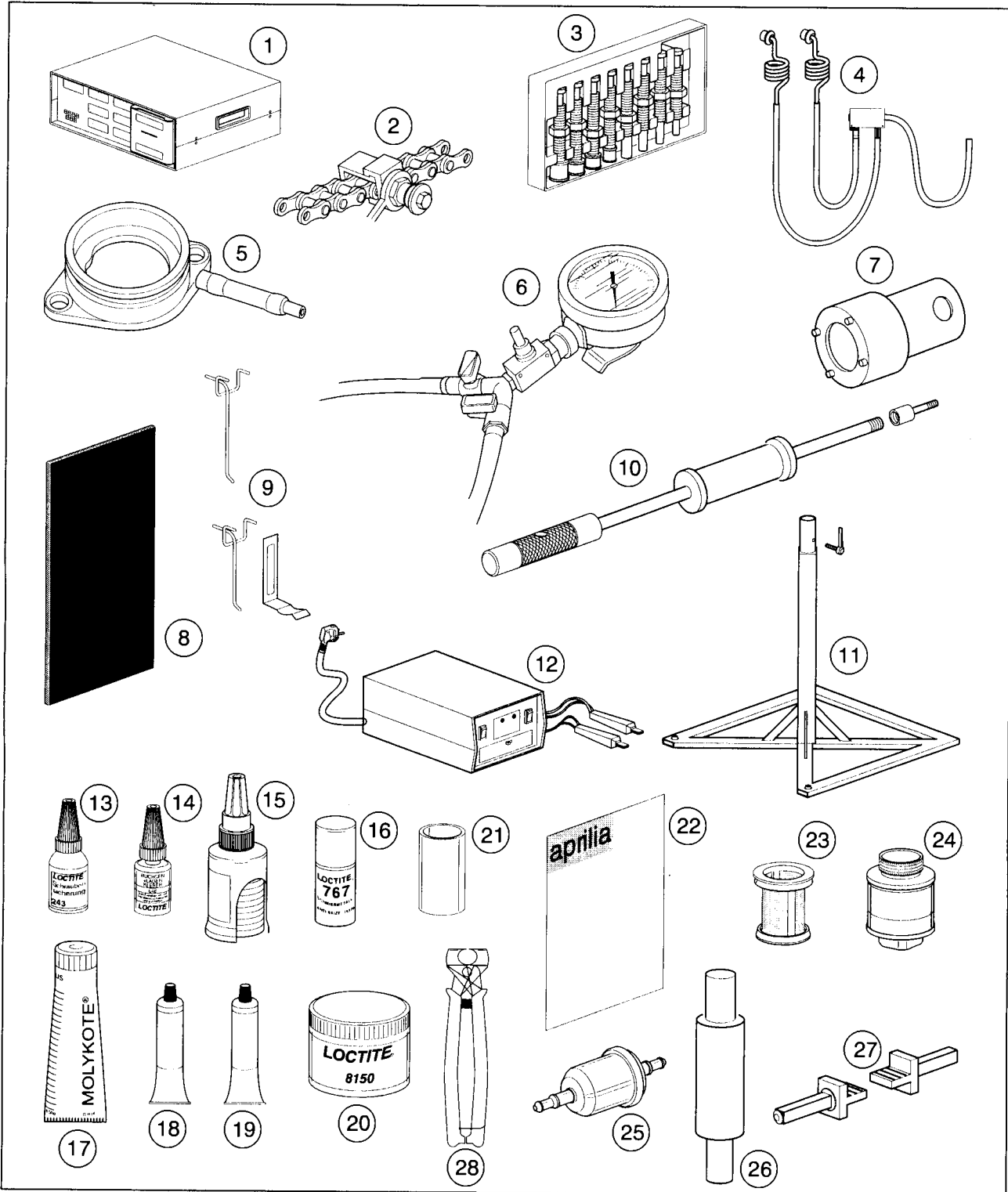

Pos.	- aprilia part# (tool description and function)	Note
1	- 8140196 (exhaust gas analyzer)	●
2	- 8140192 (chain disassembly/reassembly tool)	●
3	- 8140180 (kit for installing and removing bearings)	●
4	- 8140202 (exhaust gas analyzer tube kit)	●
5	- 8140267 (intake manifold for vacuum gauge)	●
6	- 8140256 (vacuum gauge)	●
7	- 8140424 (key for Ohlins fork)	●
8	- 8140199 (tool holder panel)	-

Follow ▶

Follow ►

Pos.	– aprilia part# (tool description and function)	Note
9	– 8140426 (panel hooks)	–
10	– 8140432 (head extractor)	●
11	– 8140187 (engine support stand)	●
12	– 8124838 (battery charger M.F.)	●
13	– 0897651 [LOCTITE® 243 blue 0.34 fl oz (10 cm ³)]	●
14	– 0899788 [LOCTITE® 648 green 0.17 oz (5 g)]	✕
15	– 0899784 (LOCTITE® 574 orange)	●
16	– 0297434 (LOCTITE® 767 Anti Seize 15378)	✕
17	– 0297433 [MOLYKOTE® G-N 1.76 oz (50 g)]	✕
18	– 0897330 (multi-purpose grease bp lz.)	●
19	– 0297386 [SILASTIC 732 RTV 3.53 oz (100 g)]	✕
20	– 8116067 (LOCTITE® 8150)	●
21	– 8140395 [particulate filter for: aprilia part# 8140196 (exhaust gas analyzer)]	●
22	– 8202222 (generic panel sticker)	–
23	– 8140396 (tabular net filter for: aprilia part# 8140196 (exhaust gas analyzer))	●
24	– 8140397 (oxygen sensor for: aprilia part# 8140196 (exhaust gas analyzer))	●
25	– 8140398 (air intake net filter for: aprilia part# 8140196 (exhaust gas analyzer))	●
26	– 8140074 (lower balanceshaft bushing extractor drift)	✕
27	– 8140204 (support for rear stand)	–
28	– 0277295 (click clamp installation pliers)	●

✕ = Special tools required in order to perform some operations described in this manual.

● = Special tools required to perform some operations described in the specific vehicle workshop manual, see 0.4.1 (VEHICLE WORKSHOP MANUAL).

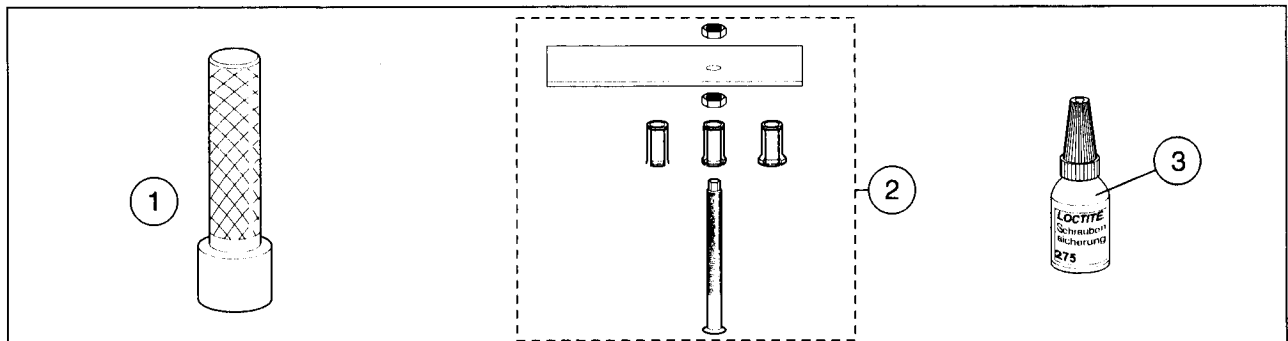
2.7.3 FURTHER aprilia VEHICLES TOOLS **OPT**

Pos.	– aprilia part# (tool description and function)	Note
1	– 0877650 (handle for drift)	✕
2	– 0277265 (balanceshaft bearings - main shaft bearings - countershaft bearings, puller)	✕
3	– 0898011 (fluorescent green LOCTITE® 275)	✕
–	– 8116050 (engine oil)	●
–	– 8116053 [Bimol Grease 481]	●
–	– 8116038 (LUBERING ST grease)	●
–	– xxxxxxx N.A. (AP-LUBE temporary lubricant)	●
–	– xxxxxxx N.A. (DID CHAIN LUBE grease)	●
–	– 8116031 ("Biosolvent" frame detergent)	●
–	– 8116945 ("ACRILON 28" cyanoacrylic glue)	●
–	– xxxxxxx N.A. (MOTUL MOTOWASH degreaser)	●
–	– 8116043 (ANTI-SEIZE MOTAGEPASTE AS 1800 antiscuff paste)	●
–	– xxxxxxx N.A. (Alcohol)	●

xxxxxxx N.A. = Not available

✕ = Special tools required in order to perform some operations described in this manual.

● = Special tools required to perform some operations described in the specific vehicle workshop manual, see 0.4.1 (VEHICLE WORKSHOP MANUAL).

2.8 FASTENERS

Carefully read 1.3.10 (FASTENERS TIGHTENING TORQUES).

2.8.1 JOINTS WITH CLICK CLAMPS AND WITH SCREW-TYPE CLAMPS

CAUTION

Remove **ONLY** the clamps indicated in the maintenance procedures.

The following text does not authorize the arbitrary removal of the clamps present on the engine.

WARNING

Before removing a clamp, make sure that the removal does not cause any fluid leakage; if so, provide for preventing such leakages and protect the parts placed around the joint.

CLICK CLAMPS

For the removal it is sufficient to use simple pliers, while for the installation a special tool is required (see below).

Before removing a clamp, prepare the material necessary for the correct installation of the new clamp.

NOTE Have the appropriate special tool  available:
– aprilia part# 0277295 (click clamp installation pliers).

CAUTION

Upon installation, replace the click clamp that has been removed with a new click clamp having the same dimensions, see 0.4.2 (SPARE PARTS CATALOGUE).

Do not attempt to reinstall the removed click clamp, since it is unusable.

Do not replace the removed click clamp with a screw-type clamp or with other types of clamps.

CAUTION

Proceed with care, in order not to damage the joint components.

- ◆ Work with the pliers on the head of the click clamp, forcing until you release it.

SCREW-TYPE CLAMPS

For the removal and installation it is sufficient to use a simple screwdriver.

CAUTION

Check the conditions of the screw-type clamp and if necessary replace it with a new screw-type clamp of the same dimensions, see 0.4.2 (SPARE PARTS CATALOGUE).

When fastening the screw-type clamp, make sure that the joint is sufficiently stable.

2.8.2 GENERAL VALUES OF TIGHTENING TORQUES

The following table shows tightening torques for screws and bolts with metric ISO threads, as is used in this engine. These are general values to be used if no specific value is given in this manual or other **aprilia** service literature.

Screw or bolt thread	Wrench	Tightening torque	
		ftlb	(Nm)
M 6	10	4.34	6
M 8	12	10.84	15
M 10	14	21.70	30
M 12	17	39.79	55
M 14	19	61.49	85
M 16	22	94.03	130

If not otherwise indicated, the tightening torques shown should be used for clean and dry threads, at room temperature.

NOTE To avoid damage to the threads, tighten screws and bolts as follows:

- ◆ Run up the fasteners finger tight.
- ◆ Applying half the prescribed tightening torque, tighten the fasteners that are diametrically opposite each other: (A) and (B); (C) and (D).
- ◆ Repeat, applying the prescribed tightening torque.

NOTE In this way the pressure exerted by the fasteners will be uniformly distributed on the joint surface.

Steel/aluminum fastening screws with similar coefficient of elasticity:

Screw	ftlb	Nm
M4	2.2	3
M5	4.4	6
M6	8.7	12
M8	18	25
M10	36	50
M12	58	80

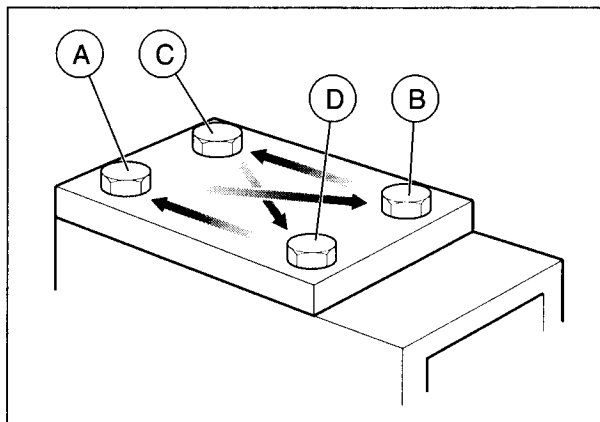

2.8.3 SPECIFIC VALUES OF TIGHTENING TORQUES

CAUTION

The fasteners featured in the table must be torqued to specification using a torque spanner and LOCTITE® applied, where indicated.

Notes:

L243 = fasten with LOCTITE® 243

L572 = fasten with LOCTITE® 572

L574 = fasten with LOCTITE® 574

L648 = fasten with LOCTITE® 648

ENGINE

Engine/Frame Fasteners

For this fasteners consult the corresponding voice in the paragraph (SPECIFIC VALUES OF TIGHTENING TORQUES) of specific vehicle workshop manual, see 0.4.1 (VEHICLE WORKSHOP MANUAL).

Engine Fasteners

Description	Q.ty	Screw/nut	ftlb	Nm	Note
Engine oil inlet flange	2	M6	8.7	12	-

For further fasteners consult the corresponding voice in the paragraph (SPECIFIC VALUES OF TIGHTENING TORQUES) of specific vehicle workshop manual, see 0.4.1 (VEHICLE WORKSHOP MANUAL).

Crankcase

Description	Q.ty	Screw/nut	ftlb	Nm	Note
Grooved ball bearings for selector roller/[alternator side (MS)] case	1	Flat-head screw M6x13	8	11	L243
Grooved ball bearings for selector roller/[clutch side (KS)] case	1	Flat-head screw M6x13	8	11	L243
Grooved ball bearings for propeller shaft/[clutch side (KS)] case	2	Flat-head screw M6x13	8	11	L243
Coolant pump idler gear/[clutch side (KS)] case	1	Pin 10	-	-	L648
Gasket [flywheel side (MS)] case/[clutch side (KS)] case	1	-	-	-	On both sides in the engine oil "labyrinth" seal area.
[alternator side (MS)] case/[clutch side (KS)] case	13	Allen screw M6x65	8	11	-
[alternator side (MS)] case/[clutch side (KS)] case	1	Allen screw M6x80	8	11	-
[alternator side (MS)] case/[clutch side (KS)] case	5	Allen screw M6x45	8	11	-
[alternator side (MS)] case/[clutch side (KS)] case	1	Allen screw M6x25	8	11	-
Case	1	Magnetic screw M12x1.5	14.5	20	-
Case	1	Contact screw M10	2.9	4	L574
Case/nozzle 75	1	Allen screw M6x10	4.4	6	-
Bearing flange [clutch side (KS)]/[alternator side (MS)]	2	Screw M8x45	18	25	-
Bearing flange [clutch side (KS)]	2	Screw M8x25	18	25	-
Bearing flange [alternator side (MS)]	1	Allen screw M8x20	18	25	-
Bearing flange [alternator side (MS)]	1	Allen screw M6x20	8	11	L243

For further fasteners consult the corresponding voice in the paragraph (SPECIFIC VALUES OF TIGHTENING TORQUES) of specific vehicle workshop manual, see 0.4.1 (VEHICLE WORKSHOP MANUAL).

Crankshaft, balancshaft, gearshift

Description	Q.ty	Screw/nut	ftlb	Nm	Note
Shifting lever/positioning disc	2	Allen screw M6x20	8	11	L243
Balancshaft [clutch side (KS)]	1	Nut M22x1.5	108	150	-
Crankshaft [clutch side (KS)]	1	Nut M33x1.5	166	230	L243
Balancshaft [alternator side (MS)]	1	Allen screw M10x20	36	50	L648

Oil pump

Description	Q.ty	Screw/nut	ftlb	Nm	Note
Oil pump	1	Without head screw with double diameter M12x1.5	-	-	Upper and lower surfaces: L574

Follow ►

Follow ►

Oil pump					
Description	Q.ty	Screw/nut	ftlb	Nm	Note
Oil pump cover	1	–	–	–	Upper and lower surfaces: L574
Oil pump lid	4	Allen screw M6x45	8	11	–









Clutch					
Description	Q.ty	Screw/nut	ftlb	Nm	Note
Countershaft [clutch side (KS)]	1	Nut M24x1.5	123	170	L648
Clutch spring	6	Screw M6x25	8	11	–
Disengagement rod	1	Locking nut M12	21.7	30	–
Complete diaphragm ring	8	Allen screw M5x20	3.6	5	–
Primary drive (spring-support plate/clutch gear/clutch housing fastening screws)	3	Screw M8x16	21.7	30	L648
Primary drive (spring-support plate/clutch gear/clutch housing fastening screws)	3	Screw M8x25/ nut M8	21.7	30	L648

Head, cylinders					
Description	Q.ty	Screw/nut	ftlb	Nm	Note
Camshaft support/head "1" (front)	8	Allen screw M6x30	8	11	–
Head "1" (front)	2	Exhaust pipe M18x1.5	9.4	13	L275
 Head "1" (front)	1	Breather nipple	20	2.0	L243
Head "2" (rear)	1	Exhaust pipe M18x1.5	9.4	13	L275
Camshaft support/head "2" (rear)	4	Allen screw M6x30	8	11	–
Camshaft support/head "2" (rear)	2	Allen screw M6x45	8	11	–
Camshaft support/head "2" (rear)	2	Allen screw M6x55	8	11	–
Head "2" (rear)	1	Cap screw M18x1.5	14.4	20	L243
Head/exhaust	6	Stud bolt M8x16/20	7.2	10	L648
Head "2" (rear)	1	Angular union	–	–	L574
Head/case	8	Stud bolt M10x171	4.4	6	L243
Cylinder/head	8	Screws with shoulder M8x45	Not varnished cylinder version 20.3-21.7 ftlb (28-30 Nm)		–
			Varnished cylinder version 18-20.3 ftlb (25-28 Nm)		
Head/stud bolt	8	Nut M10	Not varnished head version 42 ftlb (58 Nm)		Grease the nut support surface
			Varnished head version 36.2-39.8 ftlb (50-55 Nm)		
			Varnished head version (with nut on outer side) 42 ftlb (58 Nm)		
Head/chain compartment	4	Allen screw M6x100	8	11	–
Head "2" (rear)/bearing flange	2	Screw M6x35	8	11	–
Head "2" (rear)/bearing flange	2	Screw M6x20	8	11	–

Follow ►

Follow ►

Head, cylinders					
Description	Q.ty	Screw/nut	ftlb	Nm	Note
Head "1" (front)/Timing gear - exhaust camshaft	3	Allen screw M6x14	8	11	L243
Head "1" (front)/Timing gear - intake camshaft	3	Allen screw M6x14	8	11	L243
Head "1" (front)/Timing chain - guide bracket	1	Spacer screw M6x16	8	11	-
Head "2" (rear)/Timing gear - intake camshaft	3	Allen screw M6x11.5	8	11	L243
Head "2" (rear)/Drive gear (upper balanceshaft gearing) + timing gear - exhaust camshaft	3	Allen screw M6x14	8	11	L243
Head "2" (rear)/Balance weight + driven gear (upper balance-shaft gearing) - intake camshaft	1	Nut M14x1	36	50	L243
Head "2" (rear)/Timing chain guide	2	Screw M6x35	8	11	-
Valve cover	10	Spacer screw M6x23	6.6	9	-
Head	4	Spark cap	13	18	-
Induction flange	4	Allen screw M8x25	13.7	19	-
Cylinder/chain tightener	2	Cap screw M16x1.5	21.7	30	-
Head "1" (front)	1	Coolant temperature thermistor	14.5	20	-
Head "2" (rear)	1	Coolant temperature thermistor	14.5	20	-
Cylinder bracket support shoe	2	Screw Allen M10x40	29	40	-
Cylinder bracket support shoe	2	Nut M10	29	40	L243

Ignition system, starter motor					
Description	Q.ty	Screw/nut	ftlb	Nm	Note
   Crankshaft position sensor/alternator cover	2	Taptite screw M6x16	8	11	-
  Crankshaft position sensor/alternator cover	1	Taptite screw M6x12	7.2	10	L243
Alternator cover/alternator	3	Allen screw M6x40	8	11	L243
Alternator rotor/sprag clutch case/alternator ring	-	-	-	-	L648
  Alternator rotor/sprag clutch case/alternator ring	3	Allen screw M8x18	21.7	30	L648
Sprag clutch case	3	Allen screw M8x16	21.7	30	L648
Alternator rotor taper	-	-	-	-	L648
Alternator rotor/crankshaft	1	Allen screw M16x30	94	130	L648
Alternator cover/[alternator side (MS)] case	12	Allen screw M6x35	8	11	-
Alternator cover	1	Cap screw M24x1.5	Manual tightening	-	Alternator cover
  Alternator cover/cable-lock bracket	1	Allen screw M6x10	5	7	L243
Camshaft position sensor/head "1" (front)	2	Taptite screw M5x12	2.9	4	L243

For further fasteners consult the corresponding voice in the paragraph (SPECIFIC VALUES OF TIGHTENING TORQUES) of specific vehicle workshop manual, see 0.4.1 (VEHICLE WORKSHOP MANUAL).

Clutch cover, coolant pump					
Description	Q.ty	Screw/nut	ftlb	Nm	Note
Coolant pump	1	Impeller	Manual tightening, min. 5 ftlb (7 Nm)	-	-
Clutch cover	1	Oil pressure switch M10x1	10.8	15	L243
Coolant pump case	1	Allen screw M6x25	8	11	-

Follow ►

Follow ►

Clutch cover, coolant pump					
Coolant pump case	3	Allen screw M6x55	8	11	L243 only for left central screw
Clutch cover	11	Allen screw M6x35	8	11	–
Clutch cover	3	Allen screw M8x40	13.7	19	–
Clutch cover	1	Allen screw M8x65	13.7	19	–

SWINGING ARM

For this fasteners consult the corresponding voice in the paragraph (SPECIFIC VALUES OF TIGHTENING TORQUES) of specific vehicle workshop manual, see 0.4.1 (VEHICLE WORKSHOP MANUAL).

SIDE STAND

For this fasteners consult the corresponding voice in the paragraph (SPECIFIC VALUES OF TIGHTENING TORQUES) of specific vehicle workshop manual, see 0.4.1 (VEHICLE WORKSHOP MANUAL).

FRONT SUSPENSION**Front fork**

For this fasteners consult the corresponding voice in the paragraph (SPECIFIC VALUES OF TIGHTENING TORQUES) of specific vehicle workshop manual, see 0.4.1 (VEHICLE WORKSHOP MANUAL).

Steering damper

For this fasteners consult the corresponding voice in the paragraph (SPECIFIC VALUES OF TIGHTENING TORQUES) of specific vehicle workshop manual, see 0.4.1 (VEHICLE WORKSHOP MANUAL).

REAR SUSPENSION**Damper absorber**

For this fasteners consult the corresponding voice in the paragraph (SPECIFIC VALUES OF TIGHTENING TORQUES) of specific vehicle workshop manual, see 0.4.1 (VEHICLE WORKSHOP MANUAL).

Linkage

For this fasteners consult the corresponding voice in the paragraph (SPECIFIC VALUES OF TIGHTENING TORQUES) of specific vehicle workshop manual, see 0.4.1 (VEHICLE WORKSHOP MANUAL).

ELECTRICAL SYSTEM

For this fasteners consult the corresponding voice in the paragraph (SPECIFIC VALUES OF TIGHTENING TORQUES) of specific vehicle workshop manual, see 0.4.1 (VEHICLE WORKSHOP MANUAL).

AIR FILTER CASE

For this fasteners consult the corresponding voice in the paragraph (SPECIFIC VALUES OF TIGHTENING TORQUES) of specific vehicle workshop manual, see 0.4.1 (VEHICLE WORKSHOP MANUAL).

FRONT WHEEL

For this fasteners consult the corresponding voice in the paragraph (SPECIFIC VALUES OF TIGHTENING TORQUES) of specific vehicle workshop manual, see 0.4.1 (VEHICLE WORKSHOP MANUAL).

Follow ►

Follow ►

REAR WHEEL

For this fasteners consult the corresponding voice in the paragraph (SPECIFIC VALUES OF TIGHTENING TORQUES) of specific vehicle workshop manual, see 0.4.1 (VEHICLE WORKSHOP MANUAL).

COOLING SYSTEM

For this fasteners consult the corresponding voice in the paragraph (SPECIFIC VALUES OF TIGHTENING TORQUES) of specific vehicle workshop manual, see 0.4.1 (VEHICLE WORKSHOP MANUAL).

BRAKE SYSTEMS

Front system

For this fasteners consult the corresponding voice in the paragraph (SPECIFIC VALUES OF TIGHTENING TORQUES) of specific vehicle workshop manual, see 0.4.1 (VEHICLE WORKSHOP MANUAL).

Rear system

For this fasteners consult the corresponding voice in the paragraph (SPECIFIC VALUES OF TIGHTENING TORQUES) of specific vehicle workshop manual, see 0.4.1 (VEHICLE WORKSHOP MANUAL).

CLUTCH CONTROL SYSTEM

For this fasteners consult the corresponding voice in the paragraph (SPECIFIC VALUES OF TIGHTENING TORQUES) of specific vehicle workshop manual, see 0.4.1 (VEHICLE WORKSHOP MANUAL).

EXHAUST SYSTEM

For this fasteners consult the corresponding voice in the paragraph (SPECIFIC VALUES OF TIGHTENING TORQUES) of specific vehicle workshop manual, see 0.4.1 (VEHICLE WORKSHOP MANUAL).

FUEL SYSTEM

Fuel pump flange

For this fasteners consult the corresponding voice in the paragraph (SPECIFIC VALUES OF TIGHTENING TORQUES) of specific vehicle workshop manual, see 0.4.1 (VEHICLE WORKSHOP MANUAL).

Fuel tank

For this fasteners consult the corresponding voice in the paragraph (SPECIFIC VALUES OF TIGHTENING TORQUES) of specific vehicle workshop manual, see 0.4.1 (VEHICLE WORKSHOP MANUAL).

ENGINE OIL TANK AND RADIATOR

For this fasteners consult the corresponding voice in the paragraph (SPECIFIC VALUES OF TIGHTENING TORQUES) of specific vehicle workshop manual, see 0.4.1 (VEHICLE WORKSHOP MANUAL).

FRAME/FAIRINGS

For this fasteners consult the corresponding voice in the paragraph (SPECIFIC VALUES OF TIGHTENING TORQUES) of specific vehicle workshop manual, see 0.4.1 (VEHICLE WORKSHOP MANUAL).

RIGHT/LEFT HANDLEBARS AND CONTROLS

For this fasteners consult the corresponding voice in the paragraph (SPECIFIC VALUES OF TIGHTENING TORQUES) of specific vehicle workshop manual, see 0.4.1 (VEHICLE WORKSHOP MANUAL).

NOTE

THIS PAGE HAS BEEN INTENTIONALLY LEFT EMPTY

**REMOVING/REFITTING
THE COMPLETE ENGINE
FROM/TO THE VEHICLE FRAME**

3

REMOVING/REFITTING THE COMPLETE ENGINE FROM/TO THE VEHICLE FRAME

TABLE OF CONTENTS

3.1 PREFACE	3-2-00
3.2 ENGINE PARTS WHICH CAN BE DISASSEMBLED WITHOUT REMOVING THE ENGINE FROM THE FRAME	3-2-00
3.3 REMOVING THE COMPLETE ENGINE FROM THE FRAME	3-2-00
3.4 REFITTING THE ENGINE TO THE FRAME	3-2-00

3.1 PREFACE

This section contains the information and data required by the professional mechanic to remove and refit the engine, from and to, the frame of the specific **aprilia** vehicle; it also indicates the engine parts which can be removed and refitted without removing the engine from the frame.

3.2 ENGINE PARTS WHICH CAN BE DISASSEMBLED WITHOUT REMOVING THE ENGINE FROM THE FRAME

Consult the corresponding chapter in the section 3 (ENGINE) of specific vehicle workshop manual, see 0.4.1 (VEHICLE WORKSHOP MANUAL).

3.3 REMOVING THE COMPLETE ENGINE FROM THE FRAME

Consult the corresponding chapter in the section 3 (ENGINE) of specific vehicle workshop manual, see 0.4.1 (VEHICLE WORKSHOP MANUAL).

3.4 REFITTING THE ENGINE TO THE FRAME

Consult the corresponding chapter in the section 3 (ENGINE) of specific vehicle workshop manual, see 0.4.1 (VEHICLE WORKSHOP MANUAL).

NOTE

DISASSEMBLING THE ENGINE

4

DISASSEMBLING THE ENGINE

TABLE OF CONTENTS

4.1 PREFACE	4-3-00
4.2 IMPORTANT INFORMATION	4-3-00
4.2.1 ENGINE SAFETY RULES	4-3-00
4.3 TECHNICAL INFORMATION	4-4-00
4.3.1 TECHNICAL DATA	4-4-00
4.3.2 MAINTENANCE INTERVALS	4-4-00
4.3.3 TROUBLESHOOTING	4-4-00
4.3.4 SEALANTS	4-4-00
4.3.5 LUBRICANTS	4-4-00
4.3.6 SPECIAL TOOLS	4-4-00
4.3.7 TIGHTENING TORQUE	4-4-00
4.3.8 MARKS ON THE ENGINE PARTS	4-5-00
4.4 ENGINE DISASSEMBLY SEQUENCE	4-6-00
4.5 REMOVING THE STARTER MOTOR	4-7-00
4.6 DISASSEMBLING CYLINDER "1" (FRONT), HEAD AND PISTON	4-8-00
4.7 DISASSEMBLING CYLINDER "2" (REAR), HEAD AND PISTON	4-11-00
4.8 REMOVING THE ALTERNATOR COVER AND ALTERNATOR SYSTEM	4-14-00
4.9 DISASSEMBLING CYLINDER "1" (FRONT) TIMING DRIVE ASSEMBLY	4-15-00
4.10 REMOVING THE ENGINE OIL FILTER	4-15-00
4.11 REMOVING THE CLUTCH COVER	4-16-00
4.12 DISASSEMBLING THE CLUTCH	4-17-00
4.13 DISASSEMBLING THE LOWER BALANCESHAFT MECHANISM AND PRIMARY DRIVE GEAR	4-18-00
4.14 DISASSEMBLING CYLINDER "2" (REAR) TIMING DRIVE ASSEMBLY	4-19-00
4.15 REMOVING THE OIL PUMP	4-20-00
4.16 DISASSEMBLING THE GEAR SELECTION MECHANISM	4-21-00
4.17 SPLITTING THE ENGINE CASE	4-22-00
4.18 DISASSEMBLING THE CRANKSHAFT AND THE LOWER BALANCESHAFT	4-22-00
4.19 DISASSEMBLING THE GEARBOX	4-23-00

4.1 PREFACE

This section contains the information and data required by the professional mechanic to disassembly this specific **aprilia** engine.

This section is based on the knowledge that we possessed at the time of publication.

Since **aprilia** constantly strives to improve their vehicles, we reserve the right to make technical modifications and improvements to the engine.

Thus, it is possible that for some engines this section may be incomplete or in error, and some sections of this manual may not be applicable to the engine upon which you are working.

If you have any doubt as to the applicability of any statement in this section, contact **aprilia** directly.

Again, if you have any questions, do not hesitate to contact the factory directly.



4.2 IMPORTANT INFORMATION

4.2.1 ENGINE SAFETY RULES

See 1.3.7 (ENGINE GENERAL SAFETY RULES).

See 1.4.4 (ENGINE SAFETY RULES).

See 1.4.5 (REQUIREMENTS FOR ENGINE OPERATIONS WORK).

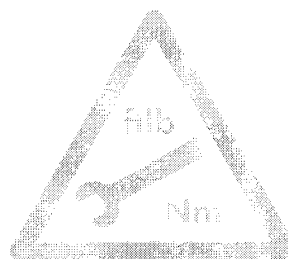

4.3 TECHNICAL INFORMATION

4.3.1 TECHNICAL DATA

See 2.4 (TECHNICAL DATA).

4.3.2 MAINTENANCE INTERVALS

See 2.2 (REGULAR SERVICE INTERVAL CHART).

4.3.3 TROUBLESHOOTING

See 8.1 (TROUBLESHOOTING).

4.3.4 SEALANTS

See 2.6 (CONSUMABLES).

4.3.5 LUBRICANTS

See 2.5 (LUBRICANT CHART).

4.3.6 SPECIAL TOOLS

See 2.7 (SPECIAL TOOLS .

4.3.7 TIGHTENING TORQUE

See 2.8 (FASTENERS).

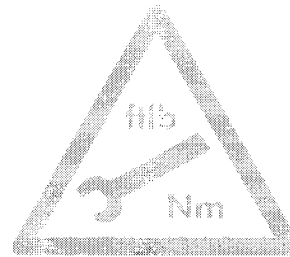
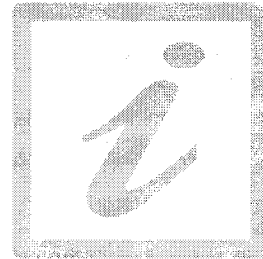

4.3.8 MARKS ON THE ENGINE PARTS

The disassembly, reassembly and replacement operations require that some parts of the engine be marked with a colored dot, letters, or reference marks.

The following table indicates the part, the type of mark, the reason for the mark and the reference to the appropriate chapter or paragraph in this specific manual.

Part		Mark (type)	Mark function	Reference to the text
Mating component	Marked component			
Engine crankcase (inside both crankcase halves).	Main bearings (installed on the engine crankcase).	Color: Red (minimum range). Blue (medium range). Yellow (maximum range).	Refers to the diameters of the bearing lands (crankshaft and bal-anceshaft) on the crankcase halves, for the selection of the size range.	5.4 (CRANKSHAFT MAIN BUSHINGS AND LOWER BALANCE-SHAFT MAIN BUSHINGS). 5.4.2 (ASSEMBLY).
Connecting rod (not marked).	Big end bearings.	Color: Red (minimum thickness). Blue (medium thickness). Yellow (maximum thickness).	Refers to the thickness of the big end bearing.	5.12 (REPLACING AND INSTALLING THE CONNECTING RODS).
Clutch cover (not marked).	Support bearings (installed on the clutch cover).	Color: Red (minimum range). Blue (medium range). Yellow (maximum range).	Refers to the diameters of the bearing lands (crankshaft and bal-anceshaft) on the clutch cover, for the selection of the size range.	5.21 (SUPPORT BEARINGS).
Valve seats (on the head) (not marked).	Valve springs.	Not present. To be made on the upper part of the springs upon disassembly.	Refers to the upper part of the springs, indispensable to ensure correct reassembly.	5.25 (DISASSEMBLING THE INTAKE AND EXHAUST VALVES). 5.30 (VALVES). 5.30.4 (ASSEMBLING THE VALVES IN THE HEAD).
Head "1" (front) (not marked).	Cylinder "2" (front).	Letter "A" or "B" stamped on the lower side of cylinder "1".	Refers to the "size range" of cylinder "1".	5.31 (CYLINDER) 5.32 (PISTON AND GUDGEON PIN). 6.13 [ASSEMBLING THE PISTON AND CYLINDER "2" (REAR)].
Head "2" (rear) (not marked).	Cylinder "2" (rear).	Letter "A" or "B" stamped on the lower side of cylinder "2".	Refers to the "size range" of cylinder "2".	6.19 [ASSEMBLING THE PISTON AND CYLINDER "1" (FRONT)].
Cylinder "1" (front).	Piston "1" (front) – original installed.	Not present. Number "1" to be stamped on the piston and the cylinder "1" upon disassembly.	Refers to the cylinder-piston set and to the position of the piston in cylinder "1".	4.6 [DISASSEMBLING CYLINDER "1" (FRONT), HEAD AND PISTON].
Cylinder "2" (rear).	Piston "2" (rear) – original installed.	Not present. Number "2" to be stamped on the piston and the cylinder "2" upon disassembly.	Refers to the cylinder-piston set and to the position of the piston in cylinder "2".	4.7 [DISASSEMBLING CYLINDER "2" (REAR), HEAD AND PISTON].
Cylinder "1" (front) with letter "A" or "B".	Piston "1" (front) – renewed.	Color: Red (range "A"). Green (range "B").	Refers to the "size range" ("A" or "B") of cylinder "1" and to the direction of assembly.	5.32 (PISTON AND GUDGEON PIN).
Cylinder "2" (rear) with letter "A" or "B".	Piston "2" (rear) – renewed.	Color: Red (range "A"). Green (range "B").	Refers to the "size range" ("A" or "B") of cylinder "2" and to the direction of assembly.	5.32 (PISTON AND GUDGEON PIN).

4.4 ENGINE DISASSEMBLY SEQUENCE

CAUTION

Any components removed must be set aside in groups arranged according to their assembly position. This will ensure that when you reassemble the engine, all parts will be fitted in their proper locations.

NOTE Before going ahead with the disassembly of the engine, gather the appropriate special tools, see 2.7 (SPECIAL TOOLS **DPT**).

NOTE This diagram shows the operations to be performed and the sequence to be followed when disassembling the engine parts.

In order to remove the parts outlined with short dashes, ([-]) the engine must be removed from the frame, see 3.3 (REMOVING THE COMPLETE ENGINE FROM THE FRAME).

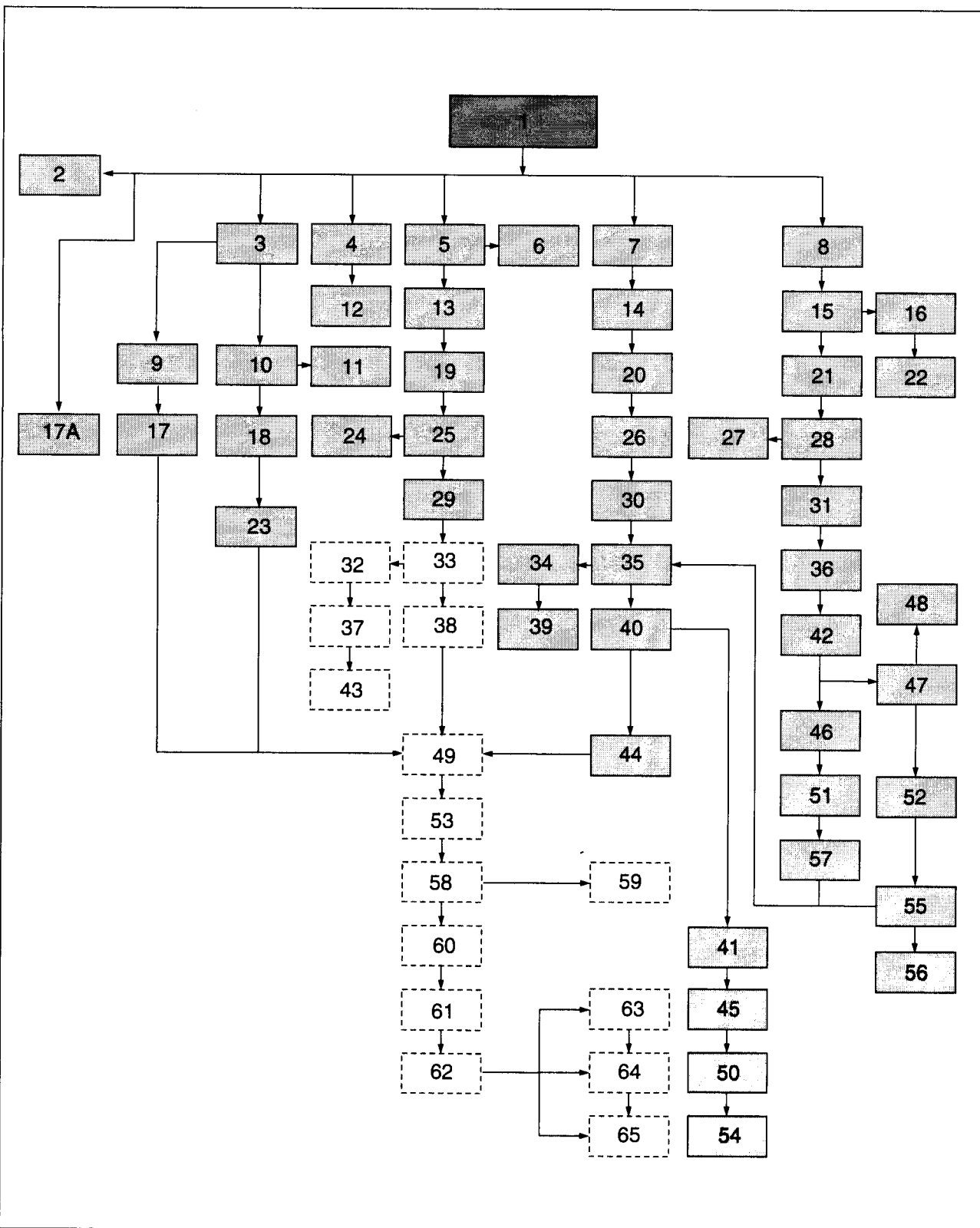

Diagram key**NOTE**

Cylinder "1" = front cylinder.
Cylinder "2" = rear cylinder.

- | | |
|--|--|
| <ul style="list-style-type: none"> 1) Engine 2) Starter motor 3) Alternator cover 4) Oil filter cover 5) Cylinder "1" tappet cover 6) Camshaft position sensor 7) Cylinder "2" tappet cover 8) Complete clutch diaphragm cover 9) Stator 10) Alternator rotor 11) Clutch 12) Oil filter cartridge 13) Cylinder "1" TDC position 14) Cylinder "2" TDC position 15) Clutch diaphragm 16) Complete support plate and disengagement rod 17) RSV RSV R SL Crankshaft position sensor 17A) RST ETV Crankshaft position sensor 18) Starter motor drive 19) Cylinder "1" timing chain tightener 20) Upper balancershaft drive 21) Coolant pump lid 22) Clutch discs 23) Cylinder "1" timing drive assembly 24) Cylinder "1" camshafts 25) Cylinder "1" timing drive gears 26) Cylinder "2" timing chain tightener 27) Coolant pump 28) Clutch cover 29) Cylinder "1" timing chain 30) Cylinder "2" timing drive gears 31) Complete support plate and disengagement rod | <ul style="list-style-type: none"> 32) Cylinder "1" head 33) Cylinder "1" head with cylinder 34) Cylinder "2" top side upper balancershaft 35) Cylinder "2" timing chain 36) Clutch discs 37) Cylinder "1" camshafts 38) Cylinder "1" piston 39) Cylinder "2" camshafts 40) Cylinder "2" head with cylinder 41) Cylinder "2" head 42) Primary drive 43) Cylinder "1" valves 44) Cylinder "2" piston 45) Cylinder "2" top side upper balancershaft 46) Balancershaft gear 47) Oil pump gear 48) Oil pump 49) Removing the engine half-case 50) Cylinder "2" camshafts 51) Coolant pump transmission 52) Complete gearshift shaft 53) Lower balancershaft 54) Cylinder "2" valves 55) Index plate 56) Index lever 57) Cylinder "2" timing drive assembly 58) Crankshaft 59) Connecting rod 60) Gearshift rods 61) Gearshift fork 62) Gearshift, shift cam 63) Drive gears 64) Gearbox bearings 65) Crankshaft, lower balancershaft |
|--|--|

4.5 REMOVING THE STARTER MOTOR

Consult the corresponding paragraph in the section 3 (ENGINE) of specific vehicle workshop manual, see 0.4.1 (VEHICLE WORKSHOP MANUAL).

4.6 DISASSEMBLING CYLINDER "1" (FRONT), HEAD AND PISTON

Carefully read 4.2 (IMPORTANT INFORMATION).

CAUTION

The head and the cylinder must be disassembled as unit. This is the only way in which the head and cylinder can be separated.

- ◆ Remove the two spark plugs (1) from the head of the cylinder "1" (front), see section 2 (SERVICE AND SETTING UP) of specific vehicle workshop manual see 0.4.1 (VEHICLE WORKSHOP MANUAL).
- ◆ Unscrew and remove the five complete M6 spacer screws (2) and remove the head cover (3) together with its gasket.
- ◆ Unscrew and remove the two M10 Allen screws (4) and remove the support bracket (5).
- ◆ Remove the plastic plug (6) and O-Ring (7) located in the center of the alternator cover.
- ◆ Remove the M8 Allen screw (8) complete with seals.
- ◆ Use a size 14 mm Allen wrench (9), turn the crankshaft counterclockwise (11) until the piston "1" is at TDC (ignition).

NOTE At the TDC (ignition), the reference marks "IN" (10) and "EX" (11) of the two gears are parallel to the head uncoupling surface, and face each other.

NOTE Have the appropriate special tool **DPT** available:
– **aprilia** part# 0240880 (threaded bolt for retaining the crankshaft at TDC) (12);

- ◆ Screw the special tool (12) into the slot previously occupied by the M8 Allen screw (8) by hand so that you can feel it fit perfectly inside the crankshaft fastening slot.

NOTE Turn the crankshaft both ways to ensure that the threaded pin is engaged perfectly. The threaded pin should not be overtightened.

Threaded pin tightening torque: max. 3.6 ftlb (5 Nm).

Follow ▶

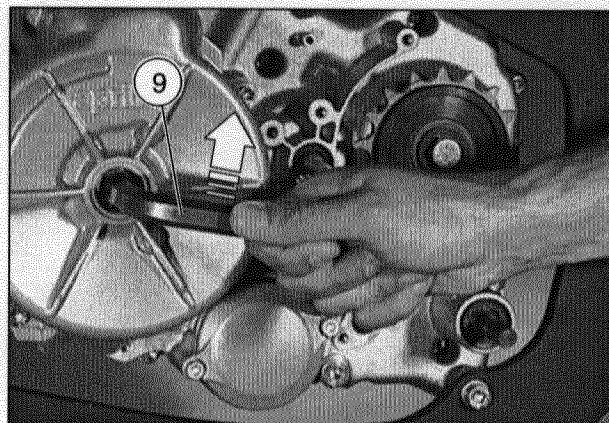
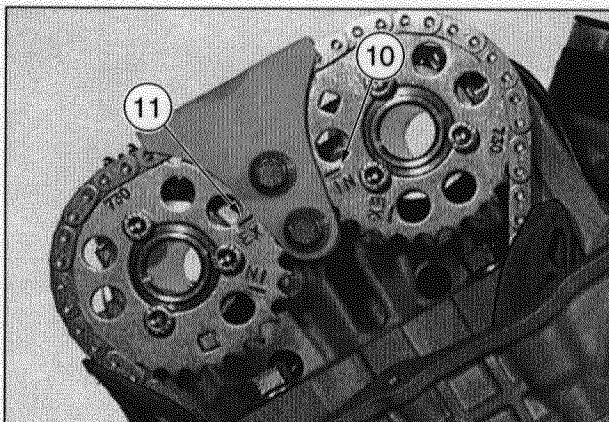
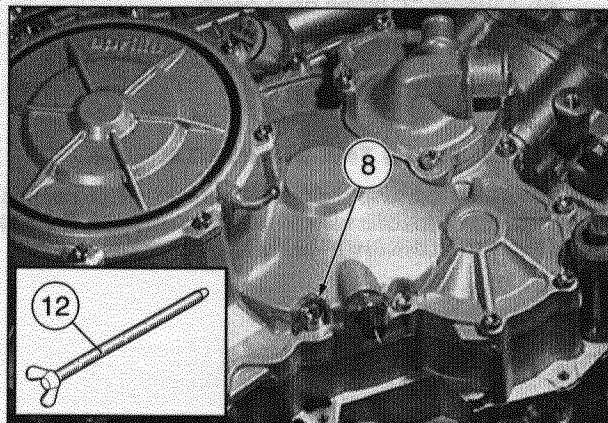
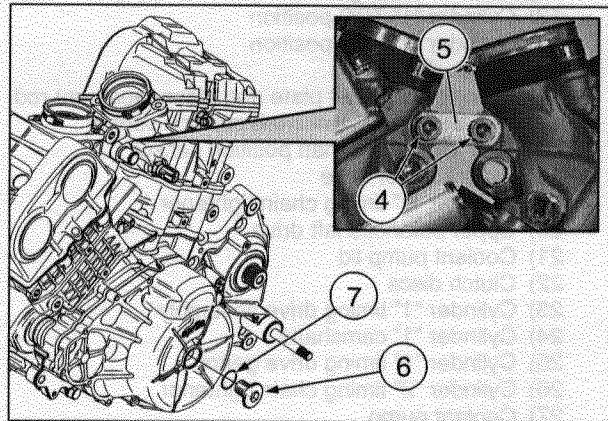
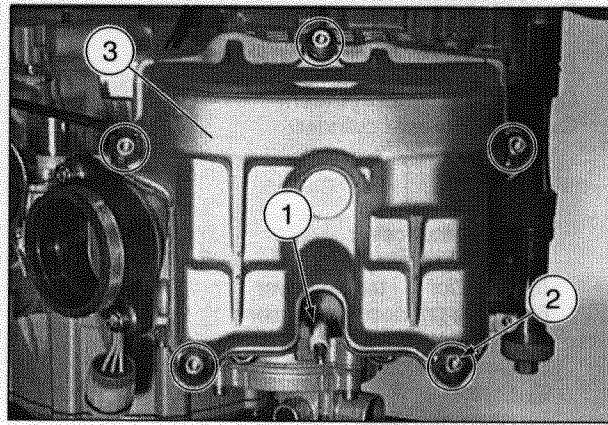

Follow ▶

- ◆ Unscrew and remove the plug (13) complete with its seal (14) and remove the complete chain tightener (15).
- ◆ Unscrew and remove the two M6 spacer screws (16) and remove the chain guide bracket (17).
- ◆ Pull the chain guide shoe (18) out from above.

⚠ WARNING

To properly reassemble the two gears (19): before removal, mark with SX and DX the left and the right gears respectively, and sign with the reference mark "A" the gears and the camshafts.

- ◆ Disengage, from the timing chain (20), the two gears (19) slide and remove them.
- ◆ Unscrew and remove the six M6x11.5 Allen screws (21).
- ◆ Let the timing chain (20) drop into the cylinders chain compartment.
- ◆ Unscrew and remove the two M6 Allen screws (22).
- ◆ Unscrew and remove the four M10 nuts (23).

⚠ WARNING

Be careful to avoid possible injury caused by allowing hands to get trapped between the cylinder and the stud bolts (24).

- ◆ Remove the cylinder (25) and complete head (26).

⚠ CAUTION

When removing the cylinder, take care not to damage the cylinder.
Be careful to keep the two locating dowels (27) from dropping inside the crankcase.

NOTE See 5.24 (HEAD AND CAMSHAFT) for instructions on taking the complete head apart.

- ◆ Cover the opening in the base with a clean cloth.
- ◆ Remove the cylinder base gasket from its groove and pull out the two locating dowels (27).

Follow ▶

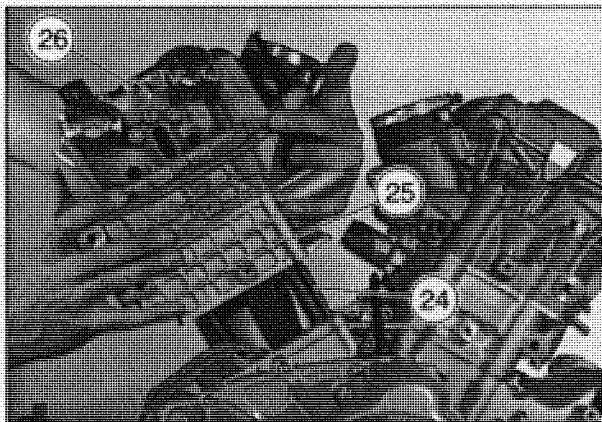
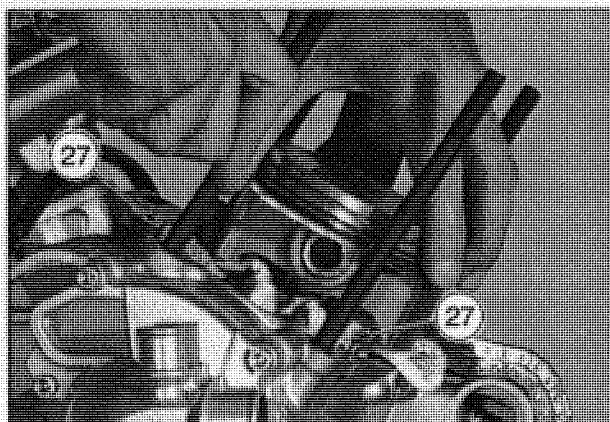
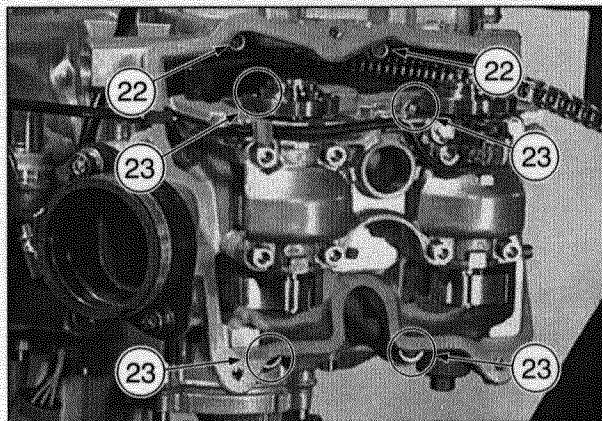
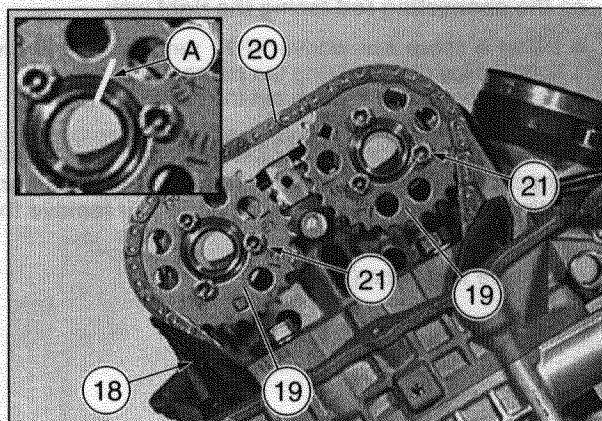
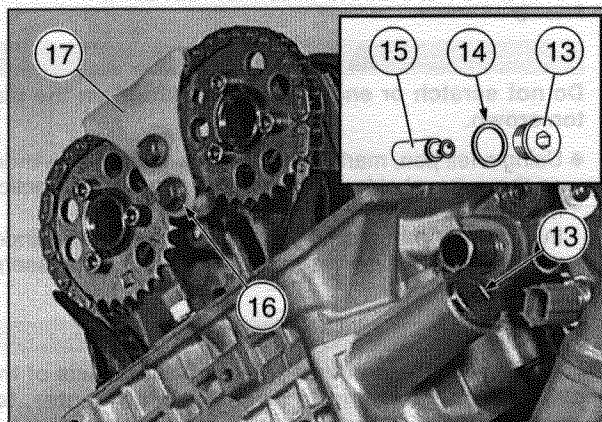

Follow ►

CAUTION

Do not scratch or engrave any markings on the piston crown.

- ◆ Using a felt pen, mark the piston crown and the cylinder on the exhaust side (28) to remind you which direction it should be reassembled in.
- In the same way, mark both the piston and the cylinder with a "1" so that the two components can be reassembled correctly.

CAUTION

In order to prevent unbalanced forces, the axis of the pistons' gudgeon pin is positioned off-center, towards the front of the vehicle.

When reassembling, the piston must be positioned on the connecting rod facing the right way.

- ◆ Using a sharp screwdriver (29), remove the left and right circlips (30) securing the piston pin.
- ◆ Using a special drift, push out the piston pin (31).

CAUTION

Support the piston with one hand so that the connecting rod is not tilted or bent while you remove the piston pin.

- ◆ Remove the piston (32).

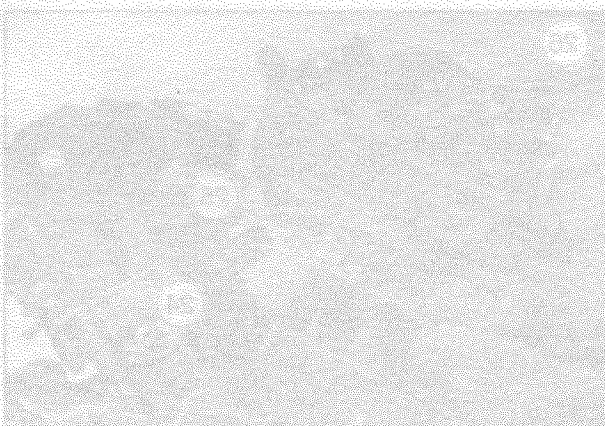
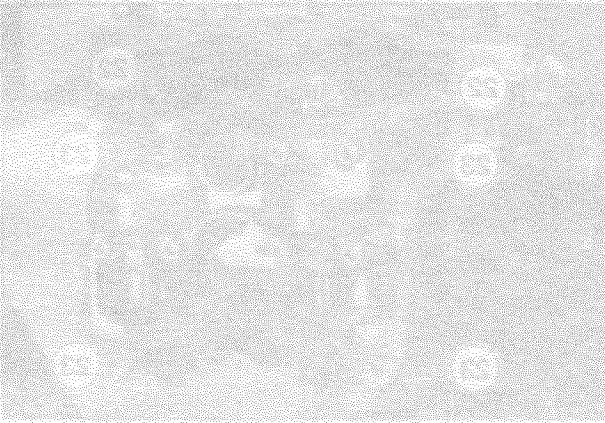
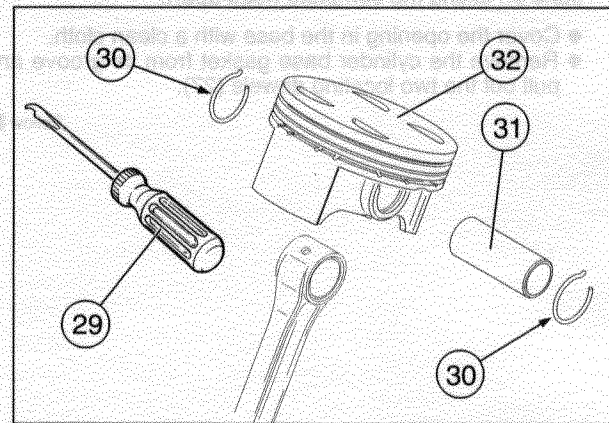
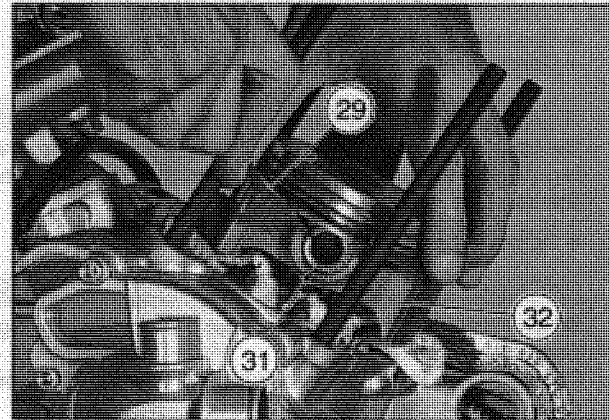
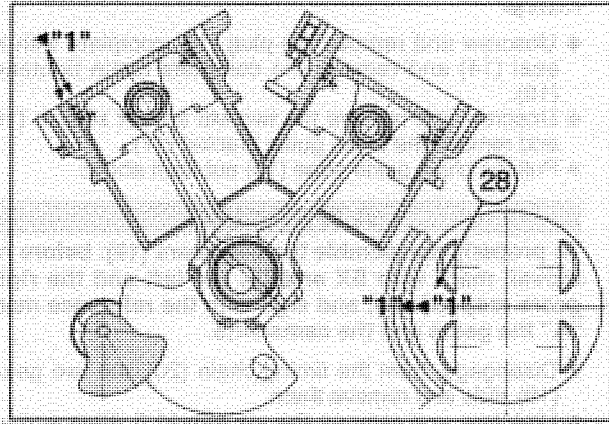

4.7 DISASSEMBLING CYLINDER "2" (REAR), HEAD AND PISTON

Carefully read 4.2 (IMPORTANT INFORMATION).

NOTE The following operations can be performed without removing the engine from the frame.

⚠ WARNING

The head and the cylinder must be disassembled as a unit. This is the way in which the head and cylinder can be separated.

⚠ WARNING

If you disassemble after removing the cylinder, the "*" marked operations are already done.

Otherwise [removal of the cylinder "2" (rear)], do not do the "*" marked operations.

- ◆ Remove the two spark plugs (1) from the head of the cylinder "2" (rear), see section 2 (SERVICE AND SETTING UP) of specific vehicle workshop manual see 0.4.1 (VEHICLE WORKSHOP MANUAL).
- ◆ Unscrew and remove the five complete M5 spacer screws (2) and remove the head cover (3) together with its gasket.
- ◆ Unscrew and remove the two M10 Allen screws (4) and remove the support bracket (5).
- ◆ Remove the plastic plug (6) and O-ring (7) located in the center of the alternator cover.
- ◆ Remove the M8 Allen screw (8) complete with seals.

⚠ WARNING

When driving gear (9) is assembled, it is not possible to read the reference marks "IN" (10) and "EX" (11) on the gear (12). You must refer to the mark "IN" (10) and "EX" (11) on the gear (13).

Do not remove the driving gear (9) in order to read the reference marks, because this causes the upper bal-anceshaft to become out of time.

⚠ CAUTION

* When turning the crankshaft, guide the connecting rod and timing chain of cylinder "1" so as to prevent them from getting stuck inside the housing.

- ◆ Using a 14 mm Allen wrench (14), turn the crankshaft counterclockwise until the piston "2" is at TDC (ignition).

NOTE At the TDC (ignition), the reference marks "IN" (10) and "EX" (11) of the two gears are parallel to the head uncoupling surface, and face each other.

NOTE Have the appropriate special tool  available:

– aprilia part# 0240880 (threaded bolt for retaining the crankshaft at TDC) (15).

- ◆ Screw the special tool (15) into the slot previously occupied by the M8 Allen screw (8) by hand so that you can feel it fit perfectly inside the crankshaft fastening slot.

NOTE Turn the crankshaft both ways to ensure that the threaded pin is engaged perfectly. The threaded pin should not be overtightened.

Threaded pin tightening torque: max. 3.6 ftlb (5 Nm).

Follow ►

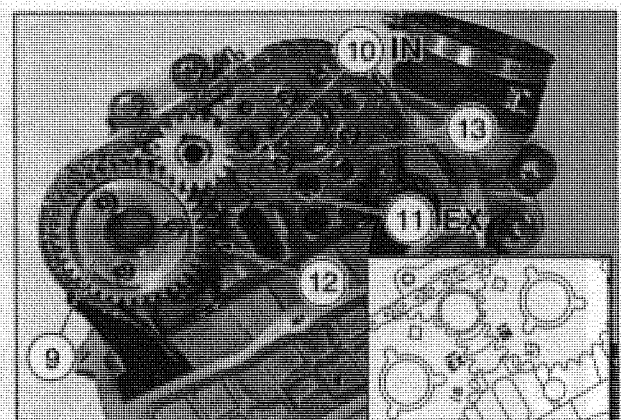
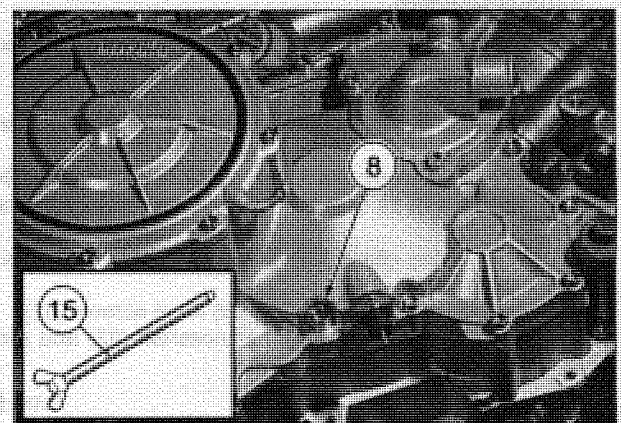
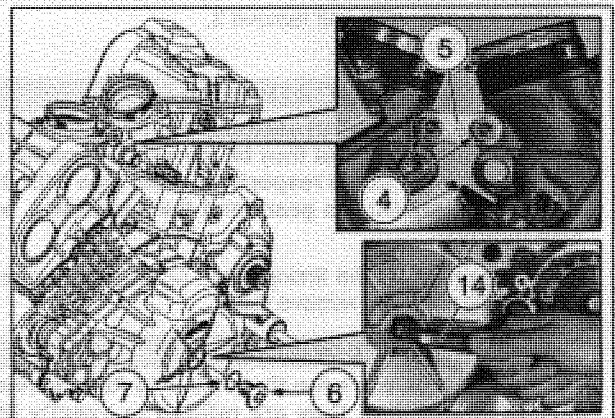
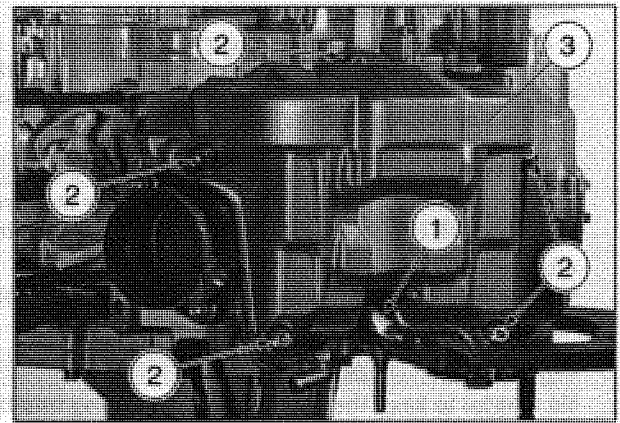

Follow ►

- ◆ Unscrew and remove the plug (16) complete with its seal (17) and remove the complete chain tightener (18).
- ◆ Insert an appropriate drift (diam. 7.5 mm) (19) in the upper balanceshaft hole (20).

CAUTION

When loosening the M14x1 nut (21), counter the force with the drift (19) so as not to strain the drive chain.

- ◆ Unscrew and remove the M14x1 nut (21).
- ◆ Remove the balanceweight (22) from the upper balanceshaft (23).

CAUTION

Be careful to keep the key (24) from dropping into the chain compartment. Cover the chain compartment with a clean cloth.

- ◆ Slide the gear (25) and remove it.
- ◆ Remove the key (24).

CAUTION

In order to properly reassemble the two gears (12) (13), it is necessary that they be marked LH and RH at the left and right gears respectively, and sign with the reference mark (A) the gears and the camshafts, before removal.

- ◆ Disengage, from the timing chain (27), the two gears (12) (13) slide and remove them.

WARNING

Before removal, mark the three M6 x 14 Allen screws (28) to ensure that they are refitted in exactly the same holes from which they were removed. Failure to do this can lead to irreparable engine failure, and a serious accident.

- ◆ Unscrew and remove the three M6 x 14 Allen screws (28).
- ◆ Slide the gear (9) and remove it.
- ◆ Unscrew and remove the three M6 x 10 Allen screws (29).
- ◆ Unscrew and remove the two M6 Allen screws (30) complete with its seal and remove the chain tightener (31).
- ◆ Let the timing chain (27) drop into the cylinder chain compartment.
- ◆ Unscrew and remove the two M6 Allen screws (32).
- ◆ Rotate upwards the upper balanceshaft (23) and slide out it.

Follow ►

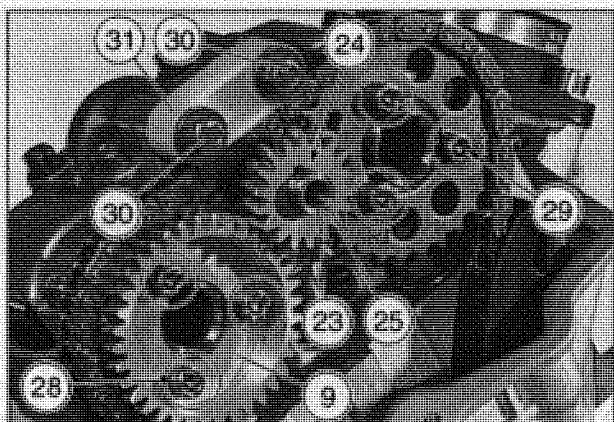
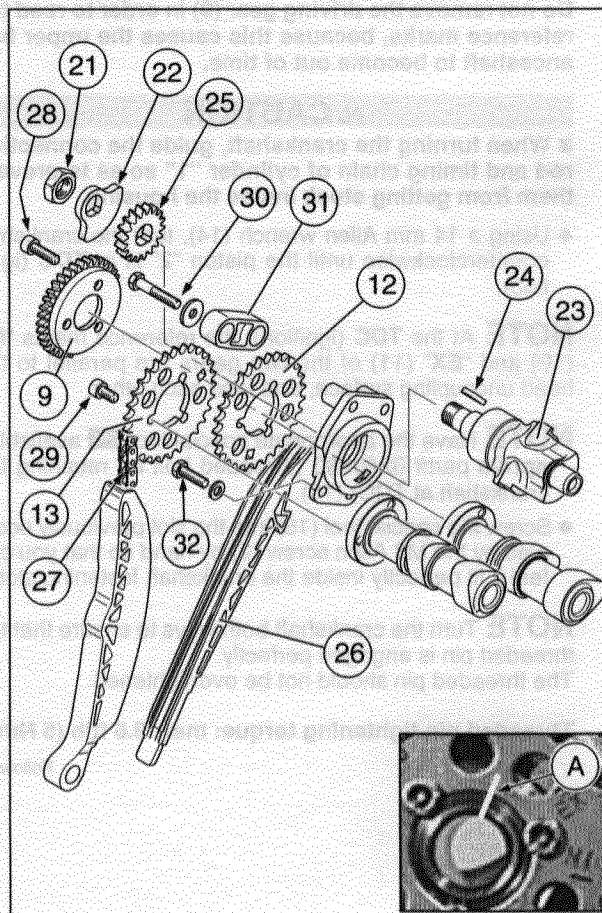
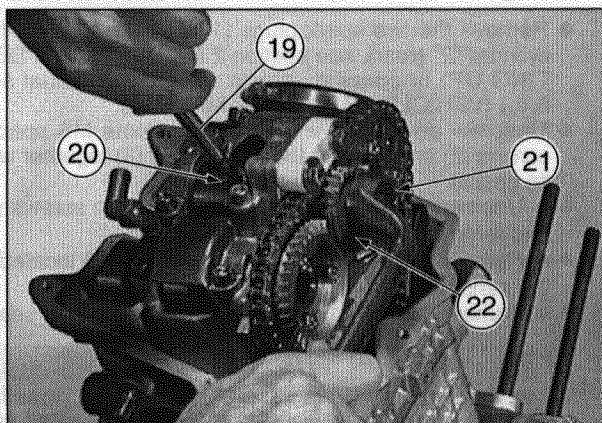
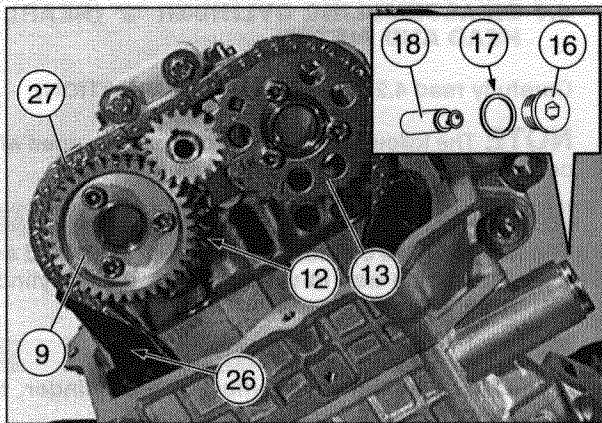

Follow ▶

- ◆ Unscrew and remove the two M6 Allen screws (33) and four M10 nuts (34).

⚠ WARNING

Be careful to avoid possible injury caused by allowing hands to get trapped between the cylinder and the stud bolts (35).

- ◆ Remove the cylinder (36) and complete head (37).

⚠ CAUTION

When removing the cylinder, take care not to damage the cylinder.
Be careful to keep the two locating dowels (30) from dropping inside the crankcase.

NOTE See 5.24 (HEAD AND CAMSHAFT) for instructions on taking the complete head apart.

- ◆ Cover the opening in the base with a clean cloth.
- ◆ Remove the cylinder base gasket from its groove and pull out the two locating dowels (38).

⚠ CAUTION

Do not scratch or engrave any markings on the piston crown.

- ◆ Using a felt pen, mark the piston crown on the exhaust side (39) to remind you which direction it should be assembled in.
In the same way, mark both the piston and the cylinder with a "2" so that the two components can be reassembled correctly.

⚠ CAUTION

In order to prevent unbalanced forces, the axis of the pistons' gudgeon pin is positioned off-center, towards the front of the vehicle.

When reassembling, the piston must be positioned on the connecting rod facing the right way.

- ◆ Using a sharp screwdriver (40), remove the left and right circlips (41) securing the piston pin.
- ◆ Use a special drift to push out the piston pin (42).

⚠ CAUTION

Support the piston with one hand so that the connecting rod is not tilted or bent while you remove the piston pin.

- ◆ Remove the piston (43).

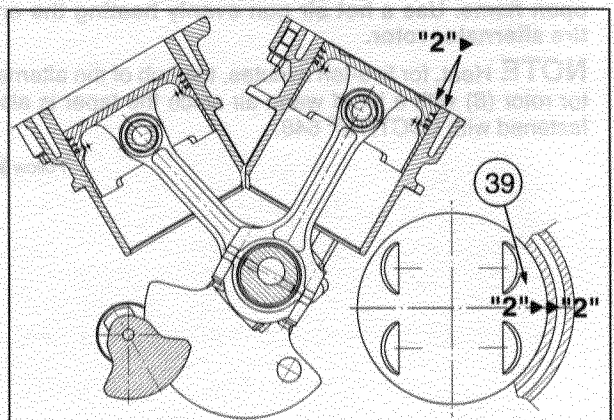
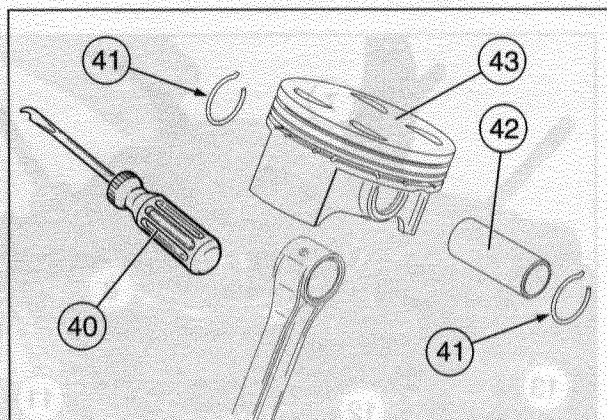
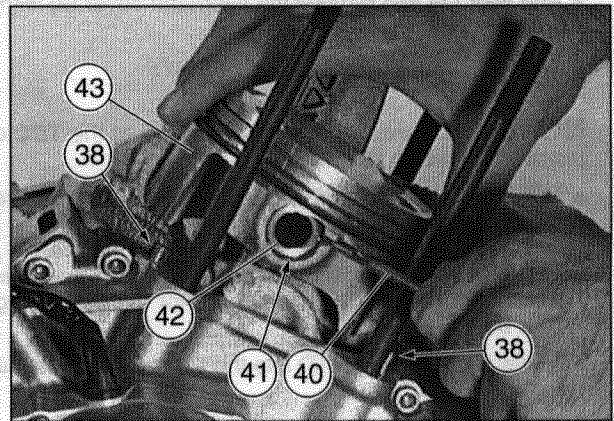
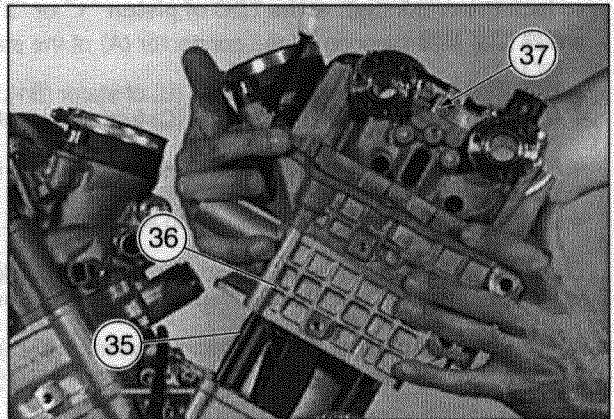
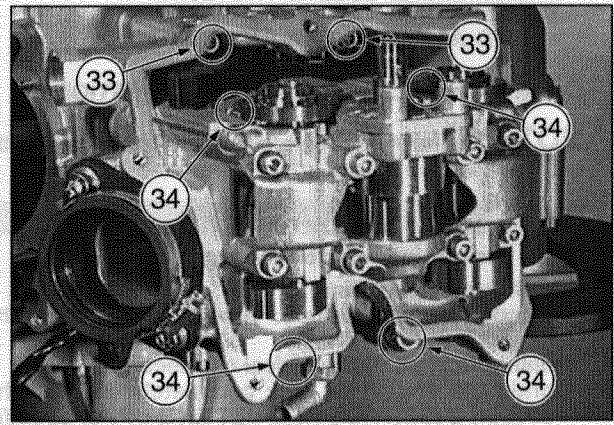







4.8 REMOVING THE ALTERNATOR COVER AND ALTERNATOR SYSTEM

Carefully read 4.2 (IMPORTANT INFORMATION).

NOTE The following operations can be performed without removing the engine from the frame.





WARNING

When performing work on the ignition system:

- switch off the engine;
 - disconnect the battery: always disconnect the negative pole (-) first;
 - disconnect all the electrical connections;
 - drain the engine oil tank completely, consult the section 2 (SERVICE AND SETTING UP) of specific vehicle workshop manual see 0.4.1 (VEHICLE WORKSHOP MANUAL);
 - lock the crankshaft at the TDC of piston "1" or "2".
- ◆    Disconnect the connector (A) of the stator (A1).
 - ◆   Disconnect the connector (B) of stator (B1).
 - ◆   Disconnect the connector (C) from the crankshaft position sensor (C1).
 - ◆ Remove the plastic plug (D) and O-ring (E) located in the center of the alternator cover (3).
 - ◆ Unscrew and remove the twelve Allen screws M6 (1).

NOTE Have the appropriate special tool  available:

- aprilia part# 0277252 (tool for removal alternator cover) (2).

- ◆ Screw the special tool (2) onto the alternator cover (3).
- ◆    Lift and remove the alternator cover (3) with:
 - stator (A1);
 - crankshaft position sensor (A2).
- ◆   Lift and remove the alternator cover (3) with:
 - stator (B1);
 - crankshaft position sensor (C1).
- ◆ Remove the gasket (4).

NOTE The crankshaft must be retained at the TDC of piston "1" or piston "2".

- ◆ Unscrew and remove the M14 Allen screw (5) and remove the washer (6).

NOTE Have the appropriate special tool  available:

- aprilia part# 0277730 (alternator rotor removal hexagonal bolt) (7).

- ◆ Screw the special tool (7) into the thread of the alternator rotor (8).

CAUTION

Never heat the hub of the alternator rotor (8) with an open flame. Use a hot air gun evenly heating the entire alternator rotor.

NOTE Heat, for five-ten minutes, the hub of the alternator rotor (8) with a jet of warm air since the taper is also fastened with LOCTITE® 648.

Follow 

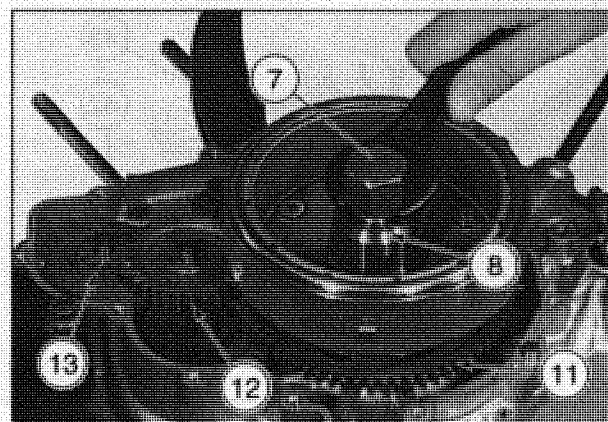
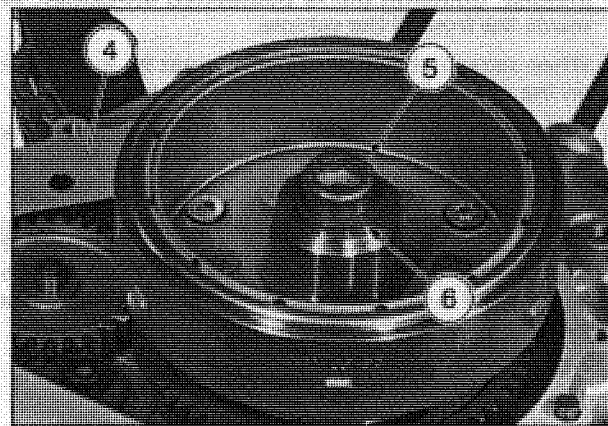
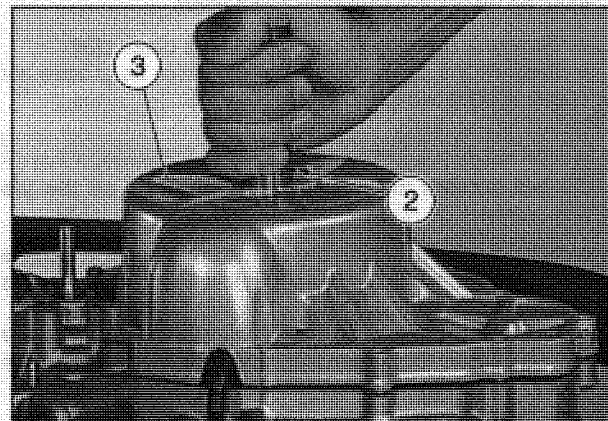
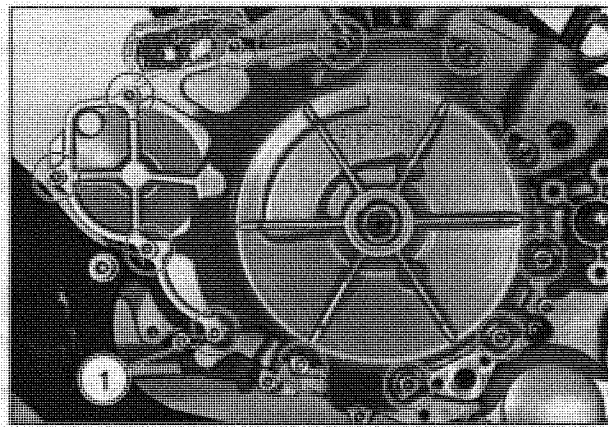

Follow ▶

- ◆ **RSV RSV R SL** Remove the alternator rotor (8) with:
 - the sprag clutch flange (9);
 - the sprag clutch (10).
- ◆ **RST ETV** Remove the alternator rotor with :
 - the sprag clutch flange (9);
 - the sprag clutch (10);
 - the alternator rotor housing (F).
- ◆ Remove the sprag clutch gear (11).
- ◆ Remove the starter idler gear (12) and double gear (13).

NOTE In order to check the sprag clutch gear (11), the starter idler gear (12) and double gear (13) see 5.33 (STARTER MOTOR DRIVE ASSEMBLY).

NOTE In order to remove or to check the alternator system, see 5.34 (ALTERNATOR **RSV RSV R SL**) or 5.35 (ALTERNATOR **RST ETV**).

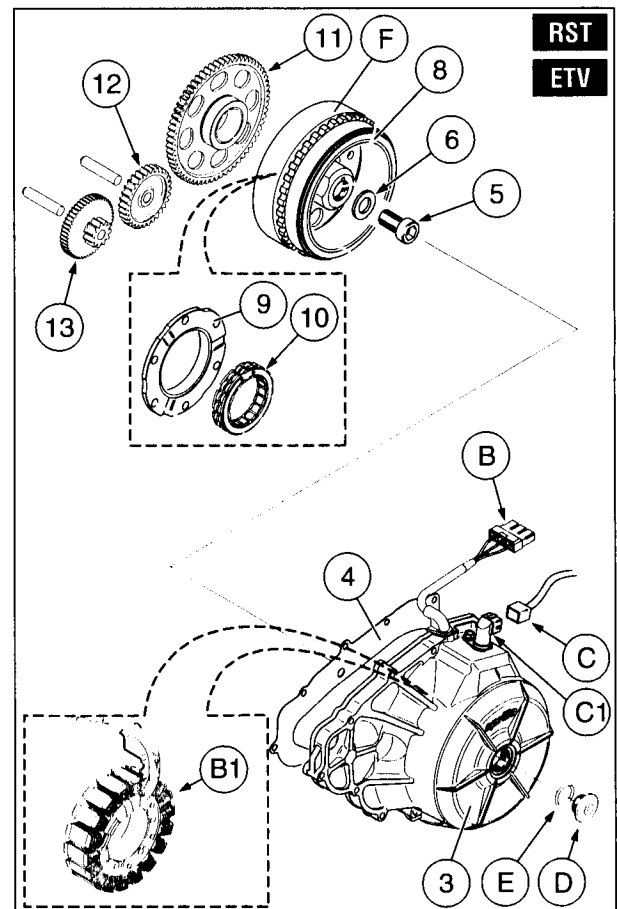
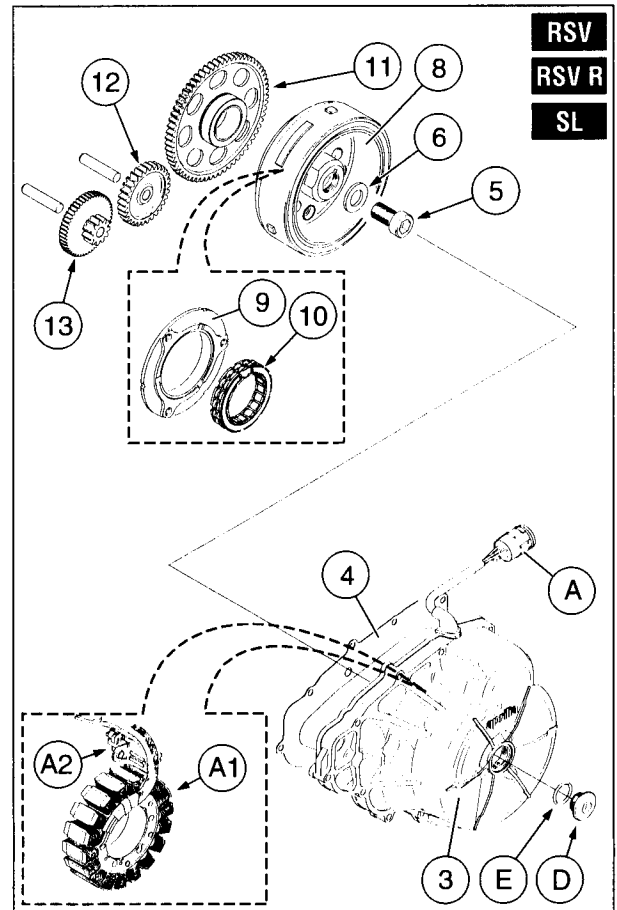

NOTE

THIS PAGE HAS BEEN INTENTIONALLY LEFT EMPTY

4.9 DISASSEMBLING CYLINDER "1" (FRONT) TIMING DRIVE ASSEMBLY

Carefully read 4.2 (IMPORTANT INFORMATION).

NOTE The following operations can be performed without removing the engine from the frame.

- ◆ Unscrew and remove the M10 Allen screw (1).
- ◆ Remove the external balanceweight (2), the drive pinion (3), the internal balanceweight (4) and the lower balancershaft key (5).
- ◆ Unscrew and remove the two M8 screws (6) and remove both spring washers (7).
- ◆ Unscrew and remove the M6 Allen screw (8) and remove the complete roller bearing flange (9).

NOTE The cylinder and the head are still fitted on the engine. In order to remove the timing chain (14), the chain tightener and camshaft gears must be removed, see 4.6 [DISASSEMBLING CYLINDER "1" (FRONT), HEAD AND PISTON].

NOTE During disassembly of the roller bearing flange (9), there is no need to remove the components (10) (11) (12) from the flange itself.

- ◆ Pull out the spacer bushing (10), the two locating dowels (11) and two roller bearings (12).

NOTE Engine # 527354 and later. The locating dowels (11) are no longer fitted: centering is achieved with the aid of the flange (9).

- ◆ Remove the chain tensioner shoe (13), pulling it out from above.

NOTE Mark the timing chain (14) with a colored dot so that you are sure to refit it with the same direction of rotation.

- ◆ Pull the timing chain (14) out from below, complete with the idler gear (15), and remove the washer (16).

4.10 REMOVING THE ENGINE OIL FILTER

Consult the section 2 (SERVICE AND SETTING UP) of specific vehicle workshop manual see 0.4.1 (VEHICLE WORKSHOP MANUAL).

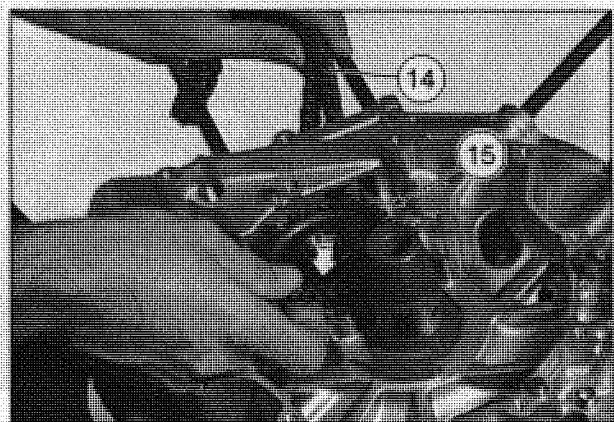
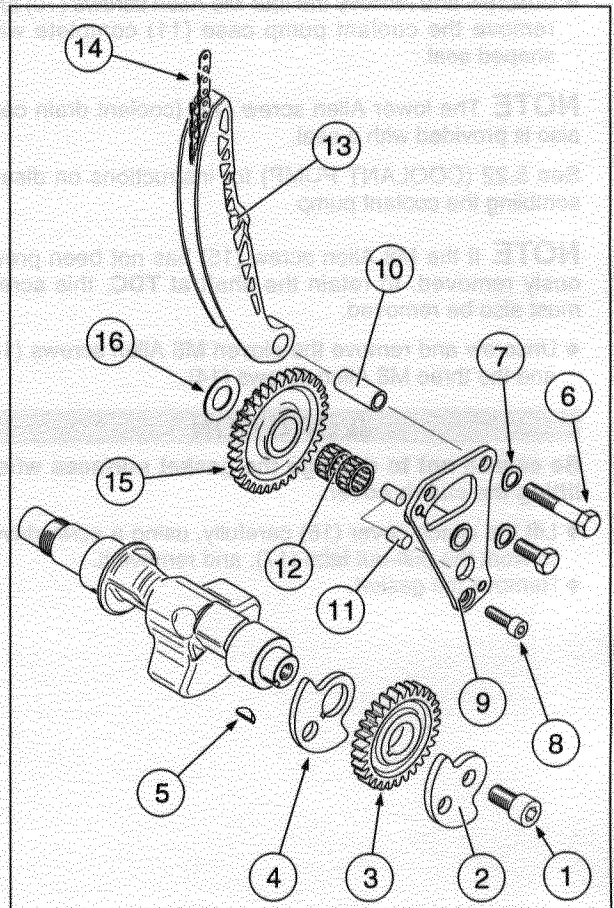
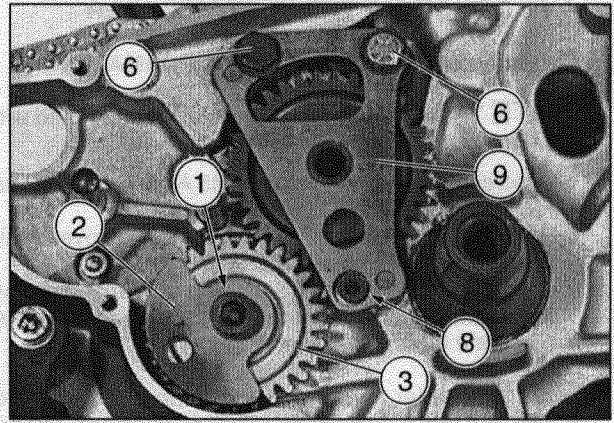

4.11 REMOVING THE CLUTCH COVER

Carefully read 4.2 (IMPORTANT INFORMATION).

NOTE The following operations can be performed without removing the engine from the frame.

- ◆ Unscrew and remove the eight M5 Allen screws (1) and remove the complete diaphragm cover (2).
- ◆ Remove the diaphragm (3) from the clutch cover retainers (4) and turn it approx. 20°.
- ◆ Unscrew and remove the M12 stop nut (5) and remove the washer (6), pressure plate (7), diaphragm (3), support plate (8) and the washer (9).

NOTE In order to unscrew and remove the M12 stop nut (5), the clutch disengaging shaft must be held still with a Allen wrench.

- ◆ Unscrew and remove the four M6 Allen screws (10) and remove the coolant pump case (11) complete with shaped seal.

NOTE The lower Allen screw (12) (coolant drain cap) also is provided with a seal.

See 5.22 (COOLANT PUMP) for instructions on disassembling the coolant pump.

NOTE If the M8 Allen screw (15) has not been previously removed, to retain the shaft at TDC, this screw must also be removed.

- ◆ Unscrew and remove the eleven M6 Allen screws (13) and the three M8 Allen screws (14).

CAUTION

Be careful not to damage the gasket surfaces when lifting the clutch cover.

- ◆ Lift the clutch cover (16) carefully, using a screwdriver to work the pull-out tabs (17), and remove it.
- ◆ Remove the gasket.

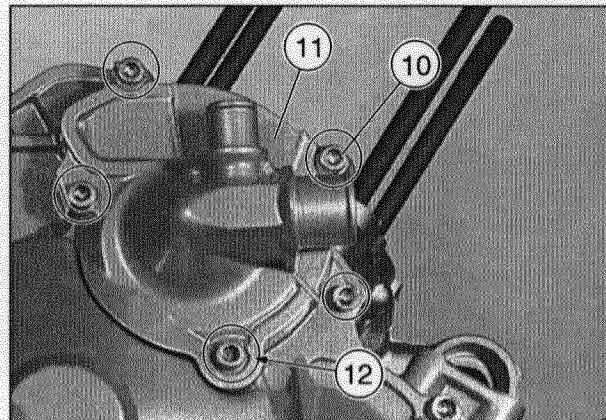
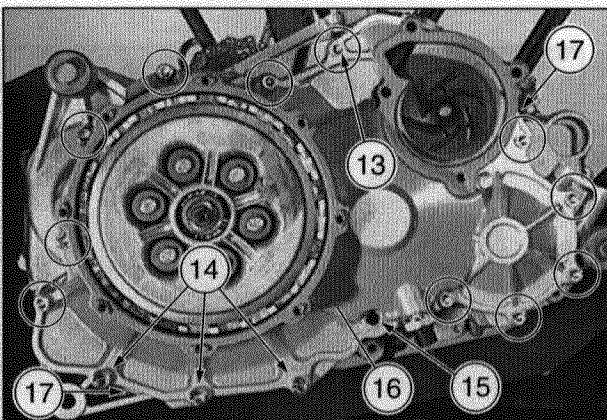
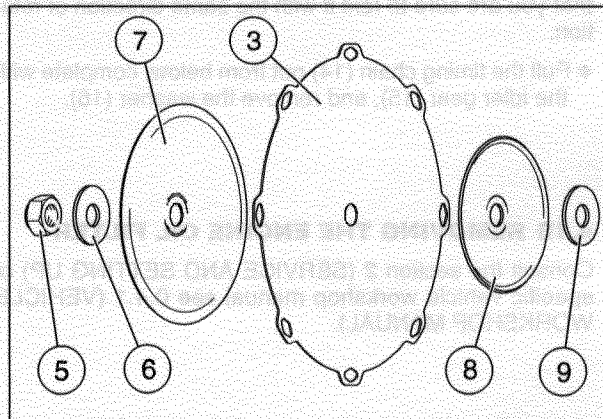
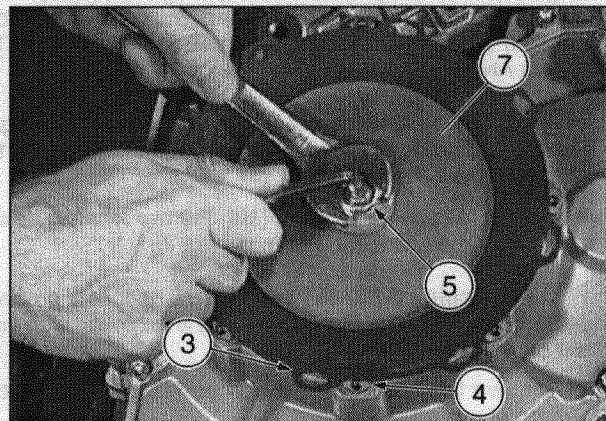
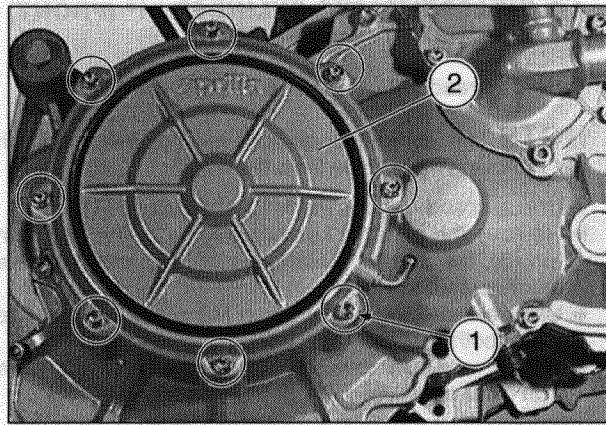

4.12 DISASSEMBLING THE CLUTCH

Carefully read 4.2 (IMPORTANT INFORMATION).

NOTE The following operations can be performed without removing the engine from the frame.

NOTE The crankshaft must be retained at TDC, see 4.6 [DISASSEMBLING CYLINDER "1" (FRONT), HEAD AND PISTON].

- ◆ Unscrew and remove the six M6 screws (1).
- ◆ Remove the washer (2), clutch springs (3) and support spring-support cups (4).
- ◆ Remove the complete clutch disengaging shaft (5).

NOTE Have the appropriate special tool **DPT** available:
– aprilia part# 8140185 (clutch disc extraction hook lever) (9).

NOTE The lower clutch discs can only be removed individually with the aid of the appropriate hook levers (9).

- ◆ Remove the lined discs (6) and steel discs (7) from the clutch housing (8).

NOTE Have the appropriate special tool **DPT** available:
– aprilia part# 0277881 (clutch locking tool) (10).

- ◆ Insert the clutch blocking tool (10) in the clutch housing (8) and on the clutch hub (11).

CAUTION

Insert the clutch blocking tool all the way into the clutch drum so as not to damage the basket when loosening the nut.

- ◆ Unscrew and remove the M24x1.5 nut (12).
- ◆ Remove the clutch blocking tool (10), spring washer (13) and clutch hub (11).
- ◆ Remove the thrust ring (14).

NOTE For instructions on disassembling the primary drive, see 5.19 (DISASSEMBLING THE PRIMARY DRIVE).

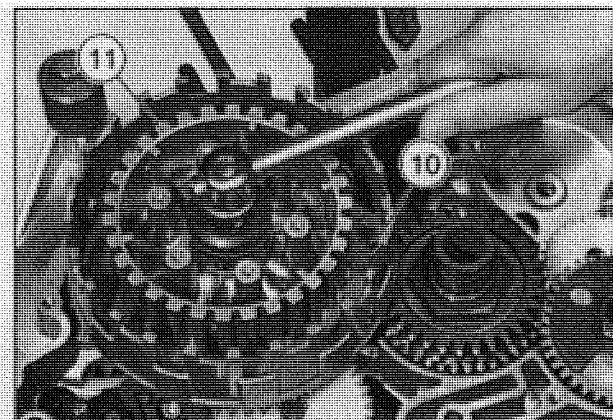
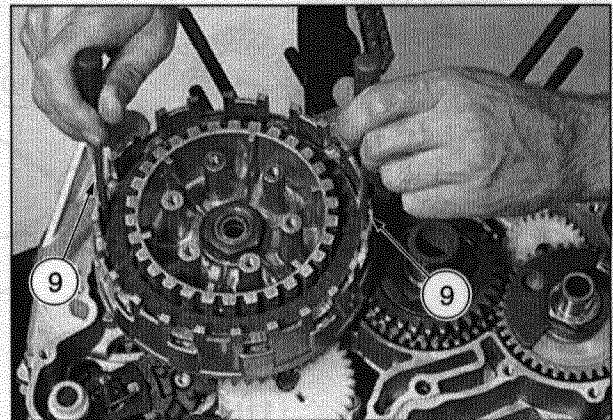
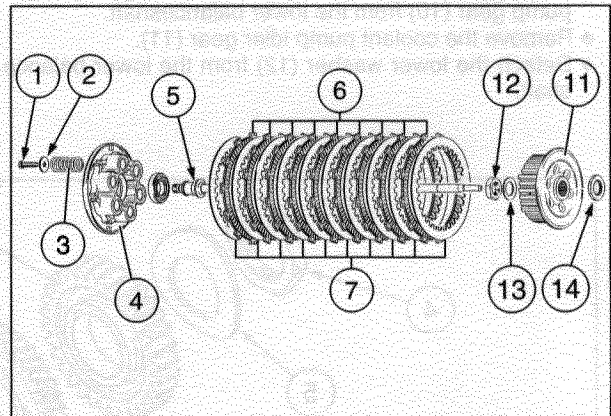
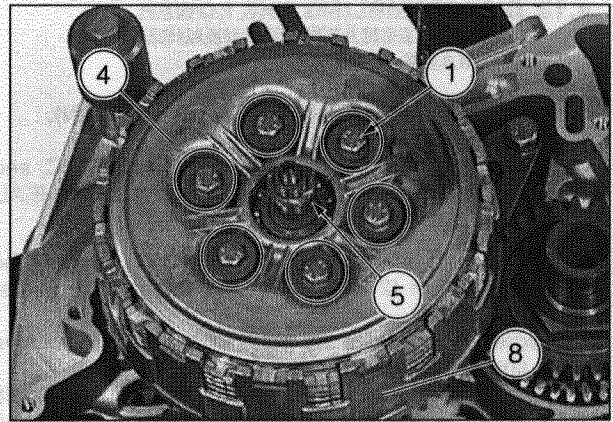

4.13 DISASSEMBLING THE LOWER BALANCESHAFT MECHANISM AND PRIMARY DRIVE GEAR

Carefully read 4.2 (IMPORTANT INFORMATION).

NOTE The crankshaft must be retained at TDC, see 4.6 [DISASSEMBLING CYLINDER "1" (FRONT), HEAD AND PISTON].

- ◆ Unscrew and remove the M22x1.5 nut (1), remove the spring washer (2) and lower balancershaft balance-weight (3).
- ◆ Unscrew and remove the M33x1.5 nut (4) and remove the spring washer (5).
- ◆ Remove the primary drive gear (6) from the crankshaft.
- ◆ Remove the differential gears (7) from the crankshaft and lower balancershaft together.
- ◆ Detach the key (8), the upper washer (9) and coolant pump gear (10) from the lower balancershaft.
- ◆ Remove the coolant pump idler gear (11).
- ◆ Detach the lower washer (12) from the lower balancershaft.

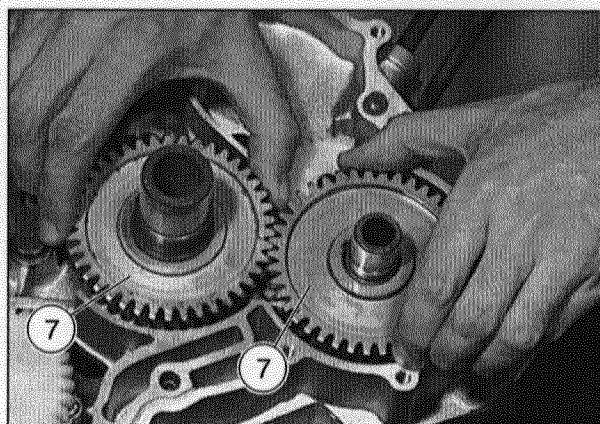
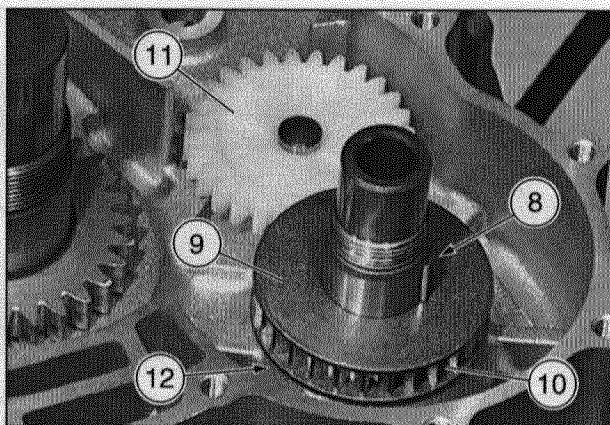
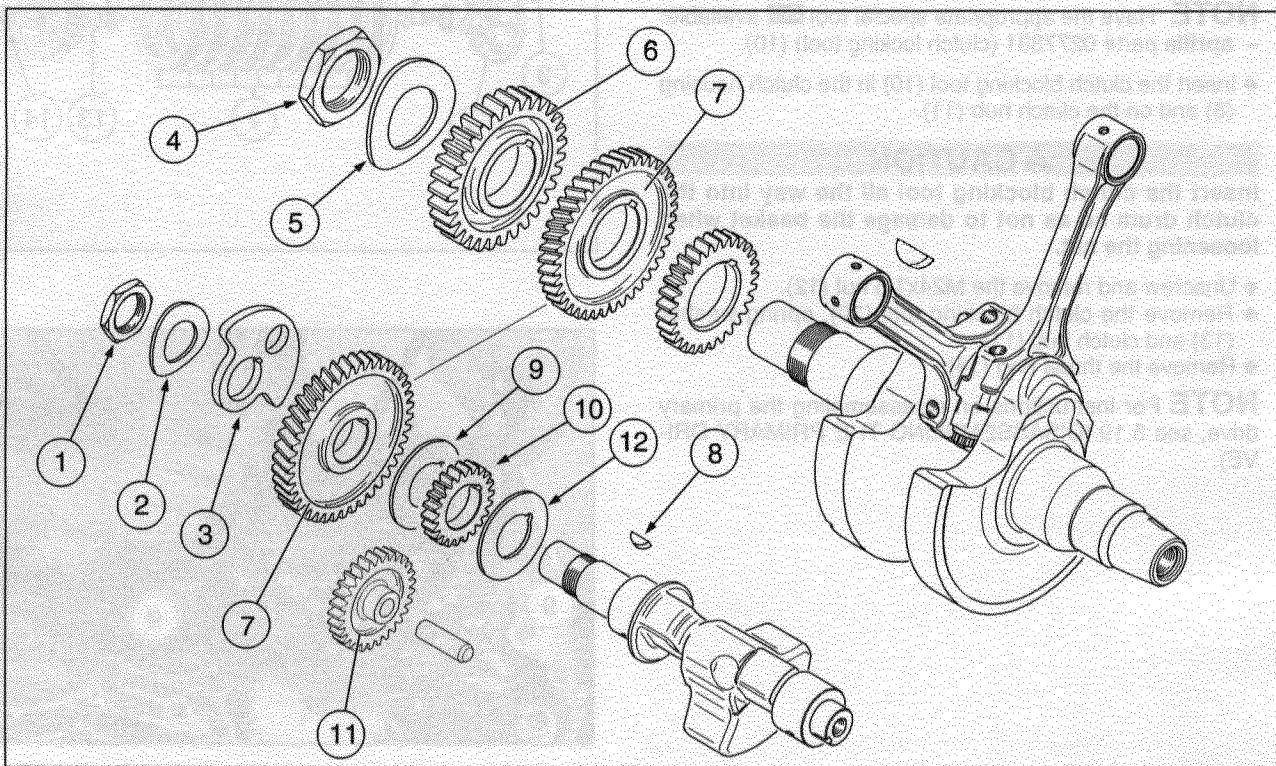
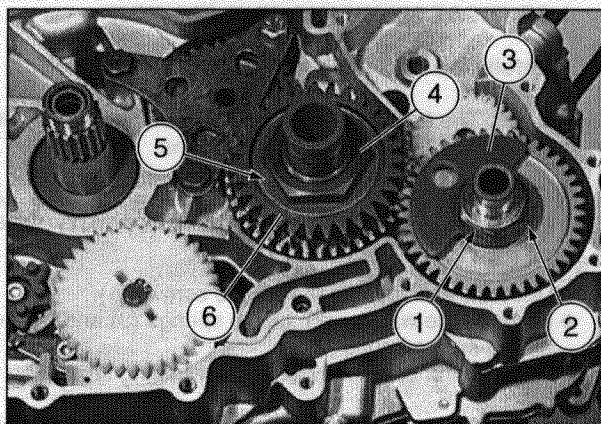

4.14 DISASSEMBLING CYLINDER "2" (REAR) TIMING DRIVE ASSEMBLY

Carefully read 4.2 (IMPORTANT INFORMATION).

- ◆ Remove the drive gear (1) from the crankshaft.
- ◆ Unscrew and remove the three M8 screws (2) and detach the lock washers (3).

NOTE The cylinder and the head are still fitted on the engine. In order to remove the timing chain (10), the chain tightener and camshaft gears must be removed, see 4.7 [DISASSEMBLING CYLINDER "2" (REAR), HEAD AND PISTON].

- ◆ Remove the complete roller bearing flange (4) along with the two precision bushings (5) and the spacer bushings (6).
- ◆ Remove the chain tensioner shoe (7), pulling it out from above.
- ◆ Remove the two roller bearings (8).
- ◆ Remove the intermediate drive gear (9) and timing chain (10), pulling both out together downwards.

NOTE Mark the timing chain (10) with a colored dot so that you are sure to refit it with the same direction of rotation.

- ◆ Remove the washer (11).

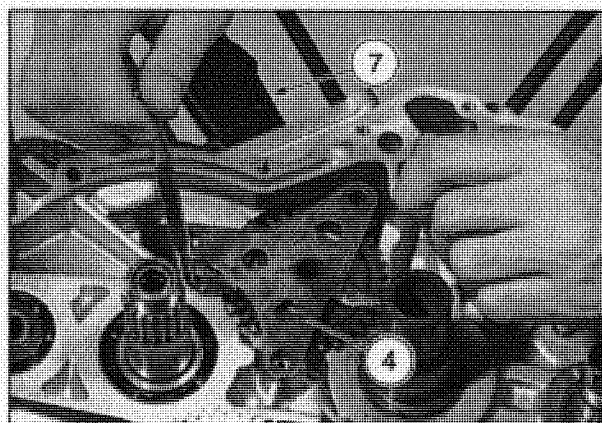
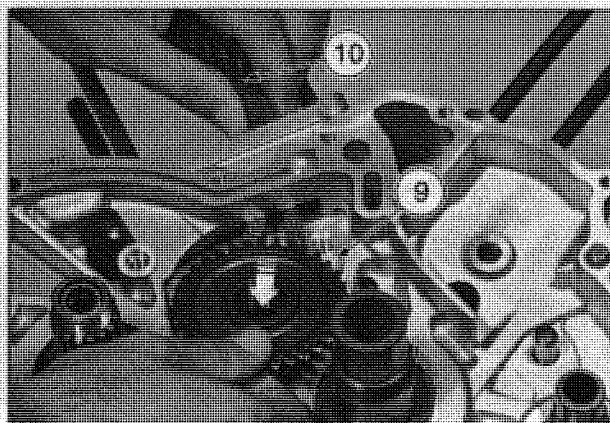
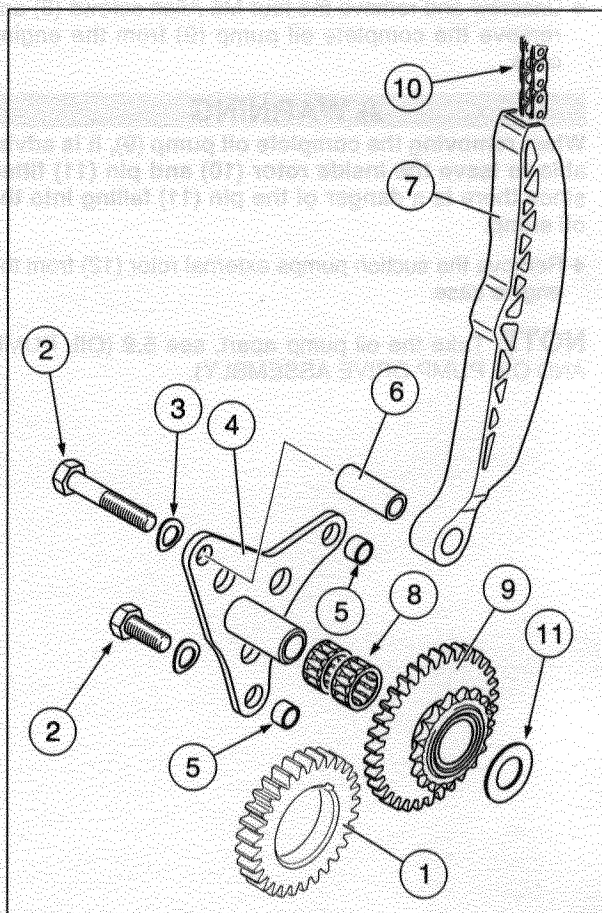
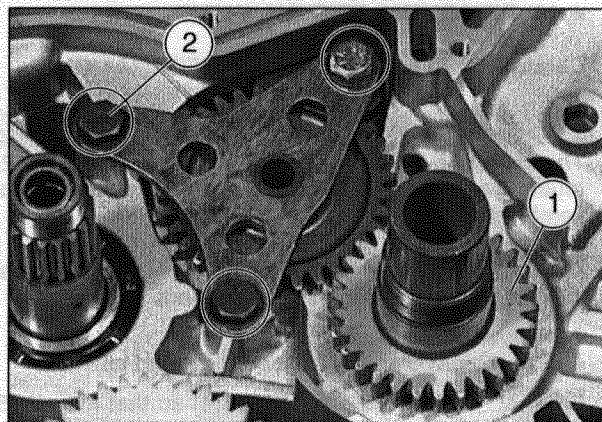

4.15 REMOVING THE OIL PUMP

Carefully read 4.2 (IMPORTANT INFORMATION).

⚠ CAUTION

The oil pump gears, both driving (1) and driven (2), must always be replaced once they have been disassembled.

NOTE The oil pump drive gear (1) is attached to the support plate of the complete clutch housing.

- ◆ Remove the circlip (3).
- ◆ Slide the oil pump driven gear (2) up and off.

NOTE Turn the oil pump shaft (4) so that the pin (5) can be slid out through the slot (6) on the pump cover (7).

- ◆ Slide the pin (5) out of the oil pump shaft (4).
- ◆ Unscrew and remove the four M6 Allen screws (8) and remove the complete oil pump (9) from the engine case.

⚠ WARNING

When removing the complete oil pump (9), it is advisable to leave the inside rotor (10) and pin (11) fitted since there is a danger of the pin (11) falling into the oil sump.

- ◆ Remove the suction pumps external rotor (12) from the engine case.

NOTE Take the oil pump apart, see 5.9 (OIL PUMP AND OIL PUMP DRIVE ASSEMBLY).

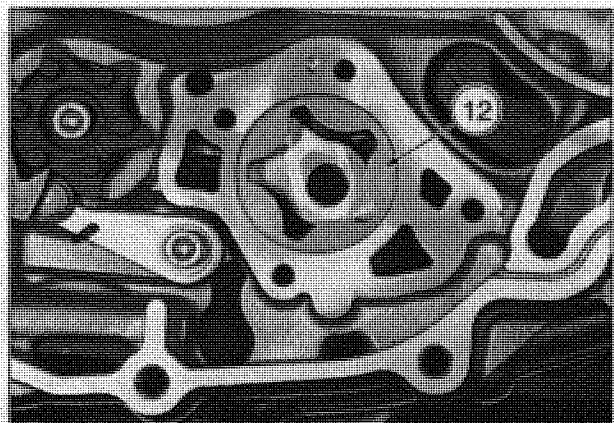
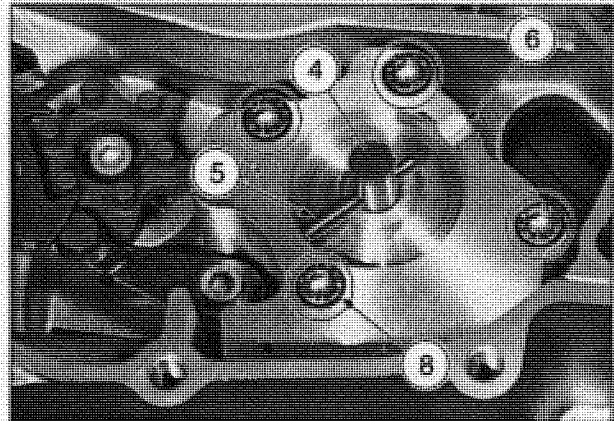
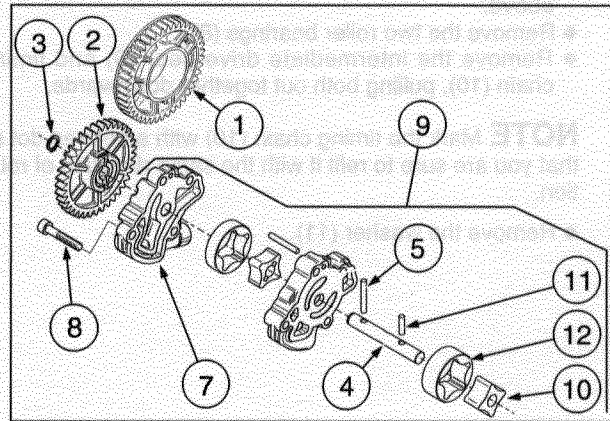
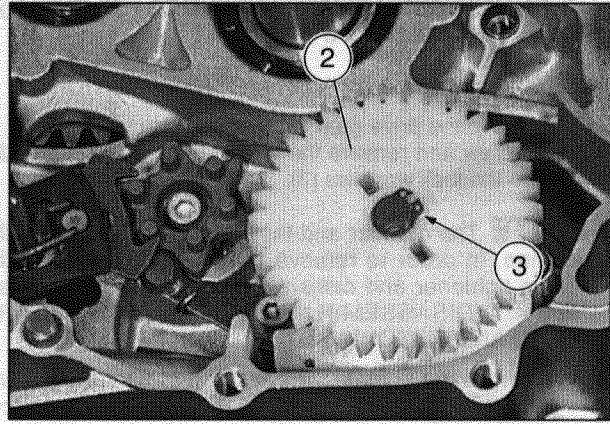

4.16 DISASSEMBLING THE GEAR SELECTION MECHANISM

Carefully read 4.2 (IMPORTANT INFORMATION).

- ◆ Unscrew the threaded pin M8 (1) retaining the crankshaft at TDC.

NOTE Turn the countershaft and the main shaft by hand to enable the gear to engage.

- ◆ Engage 6th gear.
- ◆ Remove the complete selector shaft (2).
- ◆ Unscrew and remove the M6 Allen screw (3) and remove the index plate (4).

NOTE Use a screwdriver to push the complete index lever (5) down to make it easier to remove the index plate.

- ◆ Unscrew and remove the M6 Allen screw (6) and remove the washer (7), index lever (5), graduated ring (8) and index spring (9).

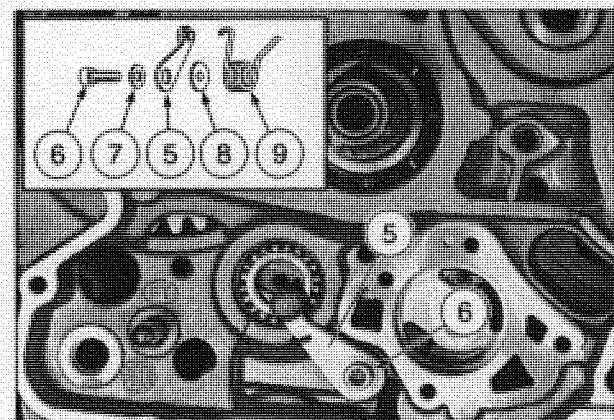
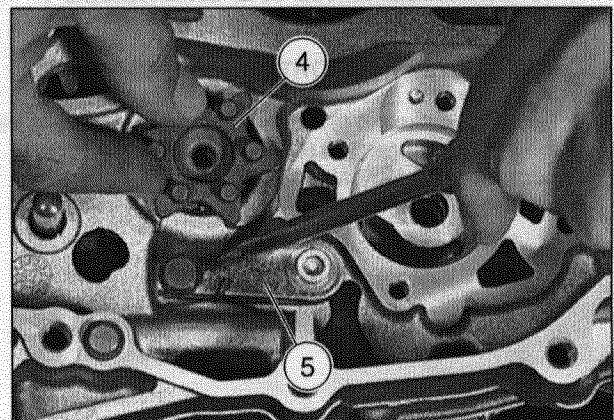
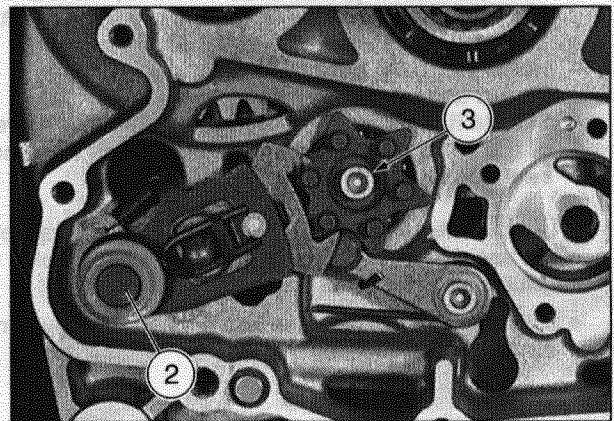
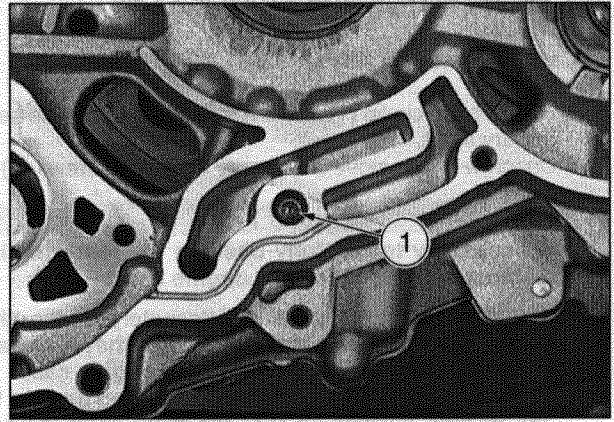

4.17 SPLITTING THE ENGINE CASE

Carefully read 4.2 (IMPORTANT INFORMATION).

- ◆ Retrieve the circlip (1) and thrust washer (2) off the secondary shaft.
- ◆ Unscrew and remove the twenty M6 Allen screws (3).

CAUTION

It is necessary to carefully observe the following instructions when splitting the engine case:

- Use a plastic mallet and alternately strike the countershaft and the main shaft until they are seated in the alternator side half of the engine case.
- Ensure that the engine half-case is lifted parallel to the parting surface so that the main bearings are not damaged.
- Where necessary, use a screwdriver, inserted in the appropriate points (4), to help pry them apart.
- Take your time and work with extreme care.
- Never strike the gasket surface.
- Do not use excessive force.
- Should it is impossible to separate the two halves of the case, check for any screws which have not been loosened.

NOTE When lifting the engine half-case, the washers of the secondary shaft may be attached on the inside of the clutch side half of the engine case.

- ◆ Split the two sections of the engine case apart by lifting the clutch side section.

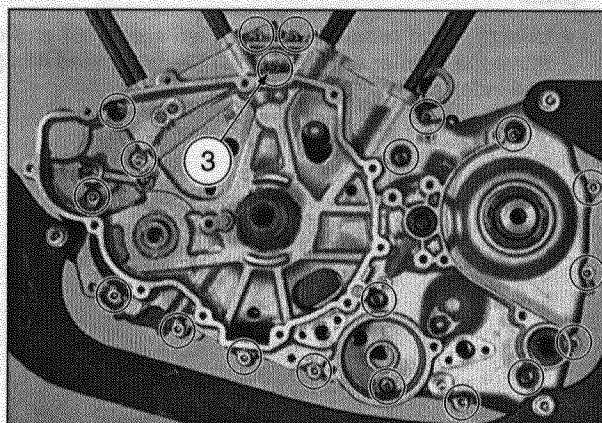
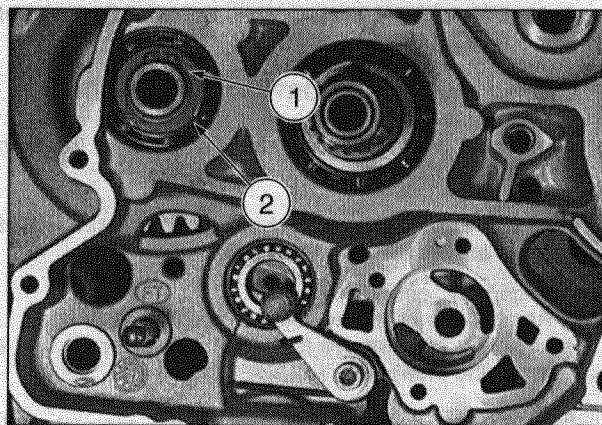
**4.18 DISASSEMBLING THE CRANKSHAFT AND THE LOWER BALANCESHAFT**

Carefully read 4.2 (IMPORTANT INFORMATION).

- ◆ Turn the crankshaft (5) so that it does not interfere with the lower balancershaft (6).
- ◆ Remove the lower balancershaft (6).
- ◆ Remove the crankshaft (5).

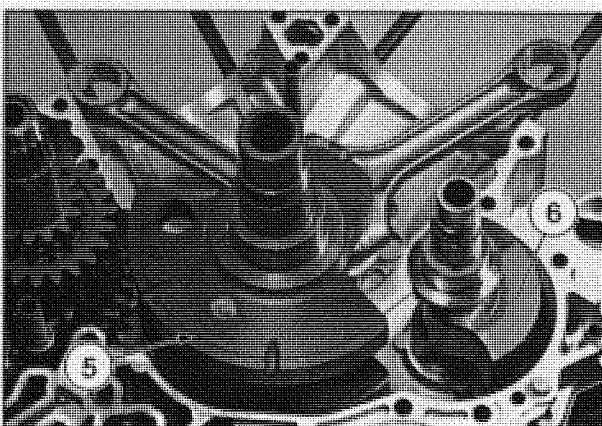
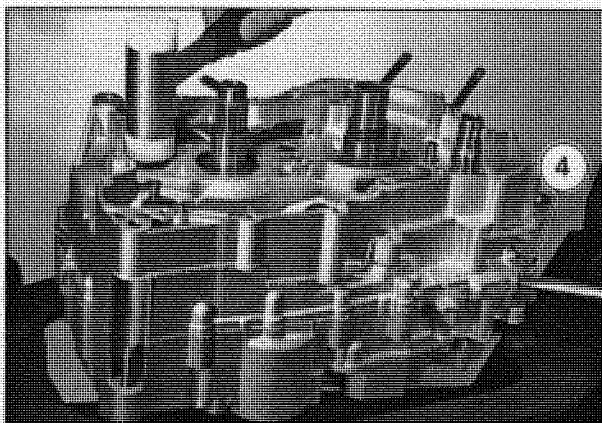

4.19 DISASSEMBLING THE GEARBOX

Carefully read 4.2 (IMPORTANT INFORMATION).

- ◆ Remove the two spindles (1).
- ◆ Turn both gearshift forks (2) of the countershaft (3) outwards, moving them away from the guides of the selector cylinder (4), and remove them.
- ◆ Turn the gearshift fork (5) of the main shaft (6) outwards, moving it away from the guide of the selector cylinder (4), and remove the selector cylinder.
- ◆ Push the 3rd and 4th gear selector gear (7) upwards and remove the fork (5) from the primary shaft.
- ◆ Set the engine half-case upright on the assembly bench.

NOTE Keep both the countershaft (3) and main shaft (6) still with one hand whilst tapping the countershaft (3) with a plastic hammer, working from the outside. This forces the two shafts out of their housings complete with the gearbox gears.

- ◆ Disassemble the gearbox (8).

CAUTION

The secondary shafts seal is inevitably damaged when disassembling the gearbox and must, therefore, be replaced.

NOTE Retrieve the gearbox apart, see 5.14 (GEARBOX).

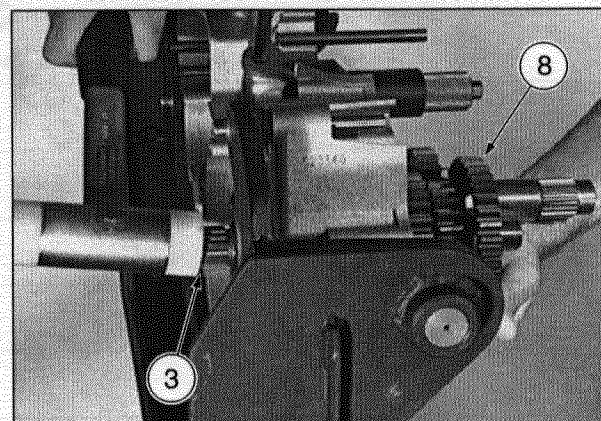
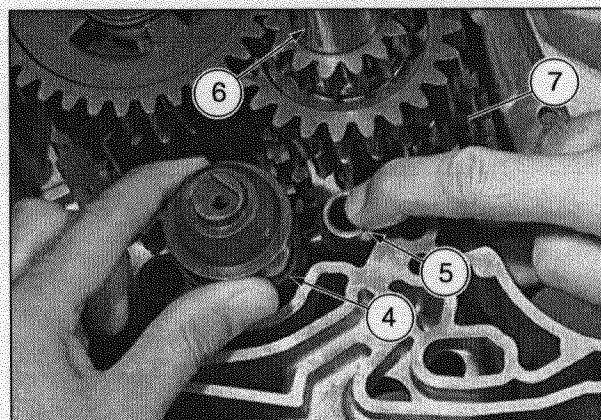
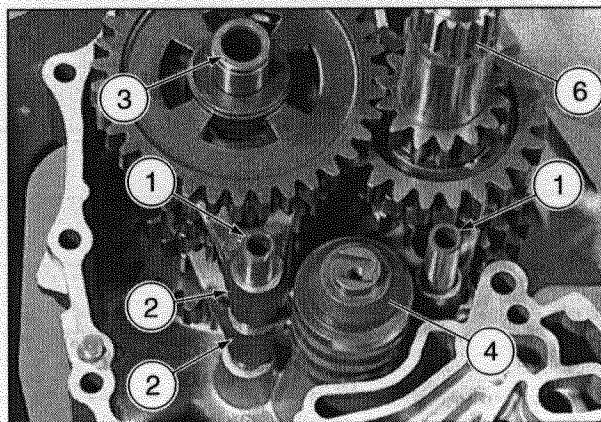

NOTE

Lined area for notes with horizontal ruling lines.

THIS PAGE HAS BEEN INTENTIONALLY LEFT EMPTY

**WORK ON THE ENGINE
INDIVIDUAL PARTS**

5

**WORK ON THE ENGINE
INDIVIDUAL PARTS**

TABLE OF CONTENTS

5.1 PREFACE 5-3-00

5.2 ENGINE CASE 5-3-00

**5.3 MAIN BEARINGS AND OIL SEALS,
MOUNTED ONTO
ENGINE HALF-CASES** 5-5-00

5.3.1 OIL SEAL DISASSEMBLY 5-5-00

5.3.2 MAIN BEARING DISASSEMBLY 5-5-00

5.3.3 MAIN BEARING ASSEMBLY 5-6-00

5.3.4 OIL SEAL ASSEMBLY 5-6-00

**5.4 CRANKSHAFT MAIN BUSHINGS
AND LOWER BALANCESHAFT
MAIN BUSHINGS** 5-7-00

5.4.1 DISASSEMBLY 5-7-00

5.4.2 ASSEMBLY 5-9-00

**5.5 REPLACING THE ENGINE
HALF-CASE CYLINDRICAL PINS** 5-12-00

5.5.1 DISASSEMBLY 5-12-00

5.5.2 ASSEMBLY 5-12-00

5.6 NEUTRAL GEAR INDICATION 5-12-00

**5.7 ASSEMBLING
THE ENGINE HALF-CASE** 5-13-00

5.8 COMPLETE OIL-SPRAY PIPE 5-13-00

5.8.1 DISASSEMBLY 5-13-00

5.8.2 ASSEMBLY 5-13-00

**5.9 OIL PUMP AND OIL PUMP
DRIVE ASSEMBLY** 5-14-00

5.9.1 DISASSEMBLING THE OIL PUMP 5-14-00

5.9.2 CHECKING THE OIL PUMP 5-14-00

5.10 CRANKSHAFT 5-16-00

**5.11 DISASSEMBLING
THE CONNECTING RODS** 5-18-00

**5.12 REPLACING AND INSTALLING
THE CONNECTING RODS** 5-19-00

**5.13 LOWER BALANCESHAFT
AND LOWER BALANCESHAFT
MECHANISM** 5-20-00

5.14 GEARBOX 5-21-00

5.14.1 TAKING THE GEARBOX APART 5-22-00

5.14.2 CHECKING 5-23-00

5.14.3 ASSEMBLY 5-25-00

5.15 GEAR SELECTION 5-26-00

5.16 CLUTCH (VERSIONS) 5-26-00

5.17 CHECKING THE CLUTCH 5-27-00

5.18 PRIMARY DRIVE (VERSIONS) 5-28-01

**5.19 DISASSEMBLING
THE PRIMARY DRIVE** 5-29-00

5.19.1 PRIMARY DRIVE
aprilia part# 0295790 5-29-00

5.19.2 PRIMARY DRIVE
aprilia part# 0295792 and 0295793 5-29-01

5.19.3 PRIMARY DRIVE WEAR LIMITS 5-29-03

5.20 CLUTCH COVER 5-30-00

5.21 SUPPORT BEARINGS 5-30-00

5.21.1 DISASSEMBLY 5-30-00

5.21.2 ASSEMBLY 5-31-00

5.22 COOLANT PUMP 5-32-00

5.22.1 DISASSEMBLY 5-32-00

5.22.2 INSPECTION 5-32-00

5.22.3 ASSEMBLY 5-33-00

5.23 CAM DRIVE ASSEMBLY 5-34-00

5.24 HEAD AND CAMSHAFT 5-35-00

5.24.1 ASSEMBLY 5-35-00

**5.25 DISASSEMBLING THE INTAKE
AND EXHAUST VALVES** 5-36-00

**5.26 CAMSHAFT
AND CAMSHAFT BEARINGS** 5-38-00

5.26.1 (CAMSHAFTS FEATURES
CLASSIFICATION) 5-39-00

5.27 UPPER BALANCESHAFT 5-40-00

**5.28 DISASSEMBLING AND REASSEMBLING
THE UPPER BALANCESHAFT
BALL BEARINGS AND OIL SEAL** 5-41-00

5.29 VALVE GUIDES 5-42-00

5.29.1 DISASSEMBLY AND REASSEMBLY 5-42-00

5.30 VALVES 5-44-00

5.30.1 VALVE SPRINGS 5-44-00

5.30.2 VALVE SEATS 5-45-00

5.30.3 GRINDING THE VALVE SEATS 5-45-00

5.30.4 ASSEMBLING
THE VALVES IN THE HEAD 5-46-00

5.31 CYLINDER 5-47-00

5.32 PISTON AND GUDGEON PIN 5-48-00

5.32.1 (PISTONS FEATURES
CLASSIFICATION) 5-49-01

**5.33 STARTER MOTOR
DRIVE ASSEMBLY** 5-50-00

5.34 ALTERNATOR **RSV** **RSV R** **SL** 5-51-00

5.34.1 TO GAIN ACCESS
TO THE ALTERNATOR **RSV** **RSV R** **SL** 5-51-00

5.34.2 CHECKING THE STATOR **RSV** **RSV R** **SL** 5-52-00

5.34.3 DISASSEMBLING
THE STATOR **RSV** **RSV R** **SL** 5-52-00

5.34.4 ASSEMBLING
THE STATOR **RSV** **RSV R** **SL** 5-52-00

5.34.5 ALTERNATOR ROTOR **RSV** **RSV R** **SL** 5-53-00

5.34.6 CHECKING
THE SPRAG CLUTCH **RSV** **RSV R** **SL** 5-53-00

5.34.7 DISASSEMBLING
THE SPRAG CLUTCH **RSV** **RSV R** **SL** 5-53-00

5.34.8 ASSEMBLING
THE SPRAG CLUTCH **RSV** **RSV R** **SL** 5-53-00

5.35 ALTERNATOR **RST** **ETV** 5-53-01

5.35.1 TO GAIN ACCESS
TO THE ALTERNATOR **RST** **ETV** 5-53-01

5.35.2 CHECKING THE STATOR **RST** **ETV** 5-53-02

5.35.3 DISASSEMBLING
THE STATOR **RST** **ETV** 5-53-02

5.35.4 ASSEMBLING
THE STATOR **RST** **ETV** 5-53-02

5.35.5 ALTERNATOR ROTOR **RST** **ETV** 5-53-03

5.35.6 CHECKING
THE SPRAG CLUTCH **RST** **ETV** 5-53-02

5.35.7 DISASSEMBLING
THE SPRAG CLUTCH **RST** **ETV** 5-53-03

5.35.8 ASSEMBLING
THE SPRAG CLUTCH **RST** **ETV** 5-53-03

5.36 SPARK PLUGS 5-53-04

5.37 COUNTERSHAFT SPROCKET 5-53-04

5.38 STARTER MOTOR 5-53-04

5.1 PREFACE

This section contains the information and data required by the professional mechanic to work on the engine individual parts.

Carefully read 4.2 (IMPORTANT INFORMATION).

CAUTION

Any components removed must be set aside in groups arranged according to their assembly position.

This will ensure that when you reassemble the engine, all parts will be fitted in their proper locations.

NOTE Before going ahead with the work on the engine individual parts, gather the appropriate special tools, see 2.7 (SPECIAL TOOLS **OPT**).

WARNING

Take care not to burn yourself when handling hot engine parts.

CAUTION

If any of the components have exceeded any of their wear limits, or if, during visual inspection of a component you determine that it is in any way defective, it must be replaced. It is false economy to reuse a marginal part. If the limits or values for measurements indicated are given with the precision of smaller than 0.004 in (0.1 mm) the temperature of the component when it is measured must be between 20 °C – 25 °C (68 °F – 77 °F).

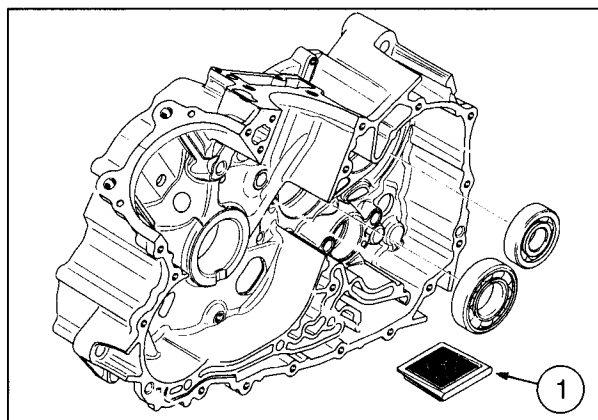
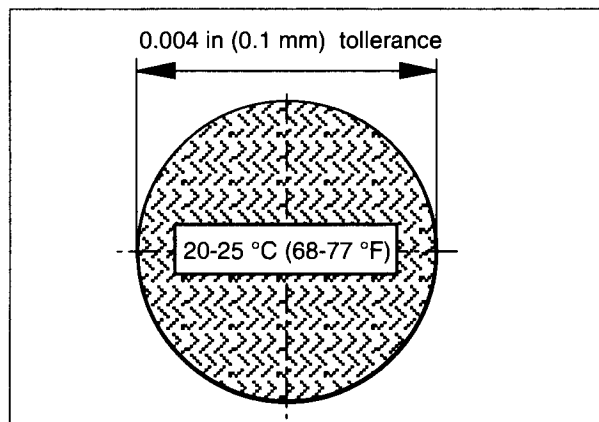

5.2 ENGINE CASE

Carefully read 5.1 (PREFACE).

CAUTION

Do not use aggressive, caustic, or acidic cleaning products or detergents while attempting to clean engine components.

Use a fire-proof solvent such as Stoddard solvent only.

- ◆ Clean the two sections of the engine case, ball bearings and all bearing housings thoroughly with a fire-proof solvent such as Stoddard solvent.
- ◆ Clean all the gasket surfaces and check for damage.

NOTE Place the two halves of the engine case on a flat surface to prevent damage.

- ◆ Ensure that the two halves of the engine case have no cracks or signs of damage.
- ◆ Ensure that all the threads are in a perfect state of repair.
- ◆ Ensure that all the oil seals remaining in their recesses are not worn or damaged.
- ◆ Check the play of all ball bearings and ensure that they roll smoothly and are not distorted. They should display no radial clearance.

NOTE Use motor oil to lubricate the ball bearings before performing the check.

If the inner race does not turn easily and silently, or if it makes a noise, it means the bearing is defective and needs replacing.

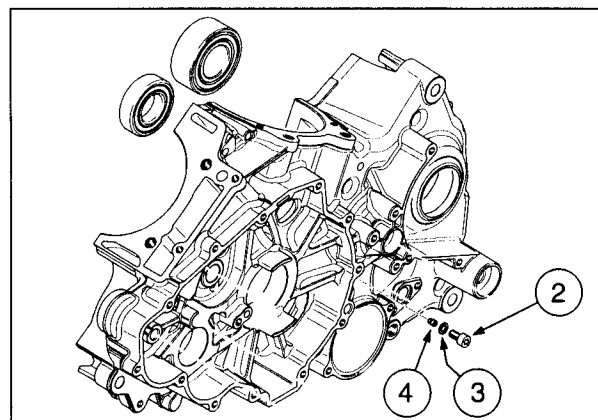

- ◆ Remove the oil filter (1).
- ◆ Clean the oil filter with a fire-proof solvent such as Stoddard solvent and check the screen for possible signs of damage.
- ◆ Unscrew and remove the M6 Allen screw (2), the seal (3) and the nozzle (4).

Follow ►

Follow ►

- ◆ Ensure that the galleries are clear in all the lubrication holes (1 - 2 - 3 - 4 - 5 - 6 - 7 - 8 - 9 - 10 - 11 - 12 - 13 - 14 - 15 - 16 - 17 - 18) in the two halves of the engine case and, where necessary, clean them by blowing a jet of compressed air inside.

ENGINE HALF-CASE, CLUTCH SIDE.

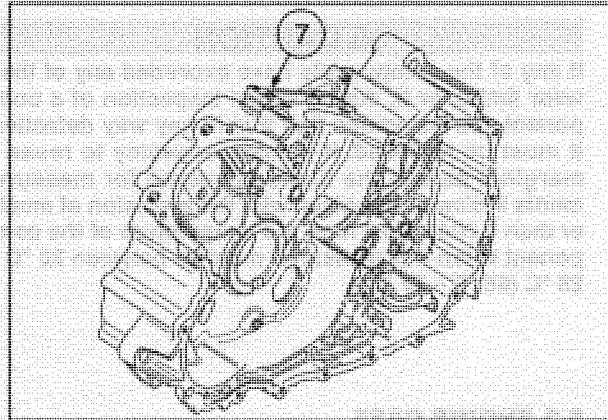
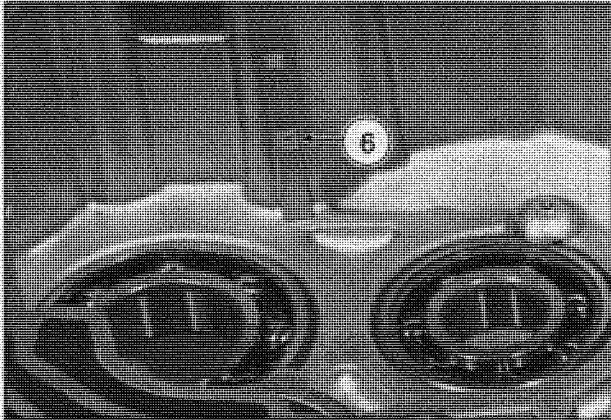
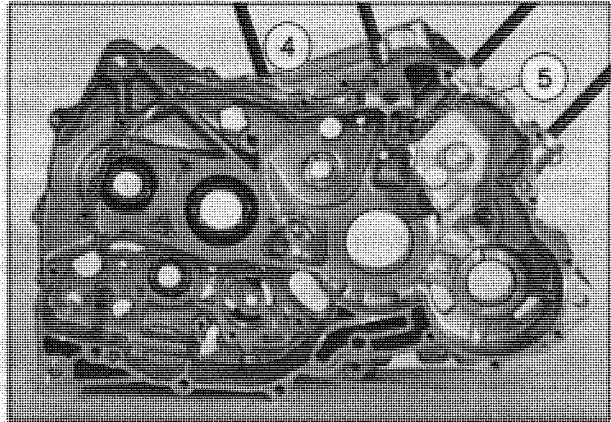
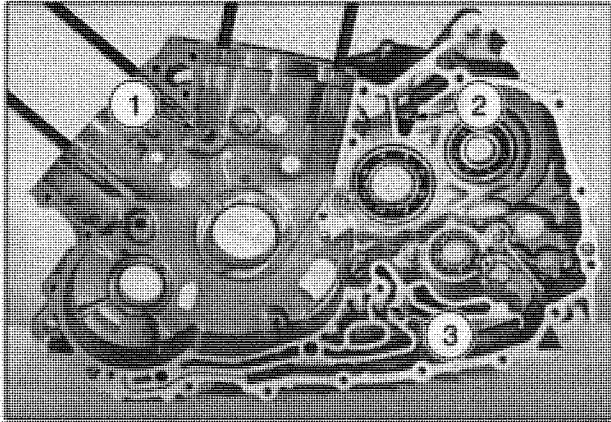

ENGINE HALF-CASE, ALTERNATOR SIDE.

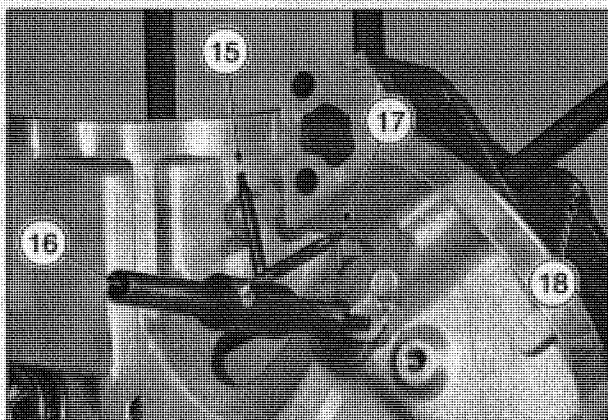
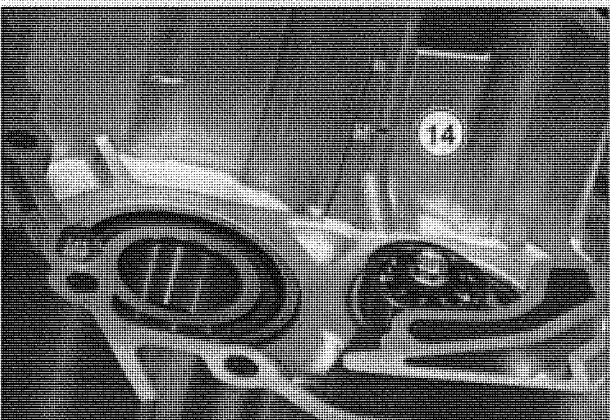
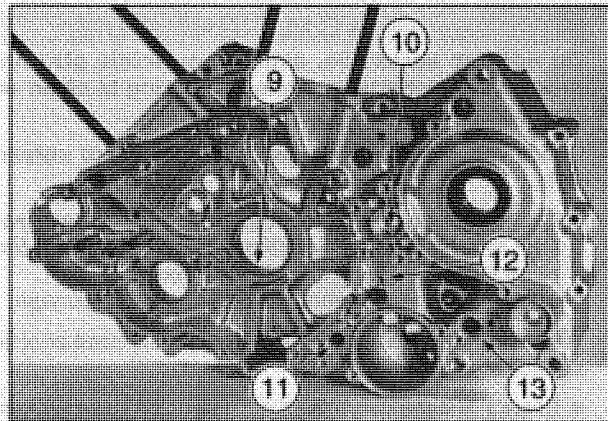
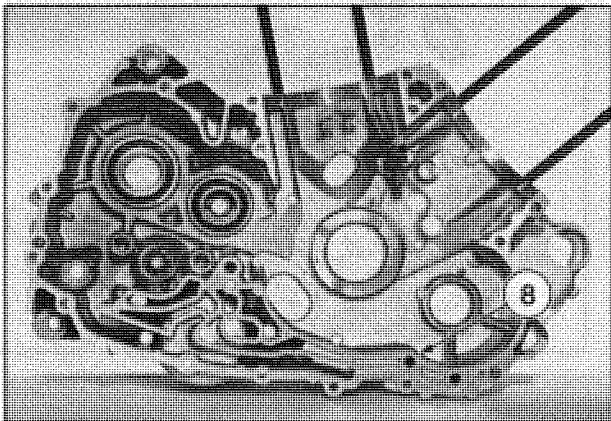

5.3 MAIN BEARINGS AND OIL SEALS, MOUNTED ONTO ENGINE HALF-CASES

Carefully read 5.1 (PREFACE).

5.3.1 OIL SEAL DISASSEMBLY

NOTE The oil seals can be disassembled and assembled without removing the engine from the vehicle.

◆ Lift and take out:

- the countershaft oil seal (1);
- the selector shaft oil seal (2);
- the clutch disengaging shaft oil seal (3).

NOTE As a rule, the disassembled oil seals should be replaced.

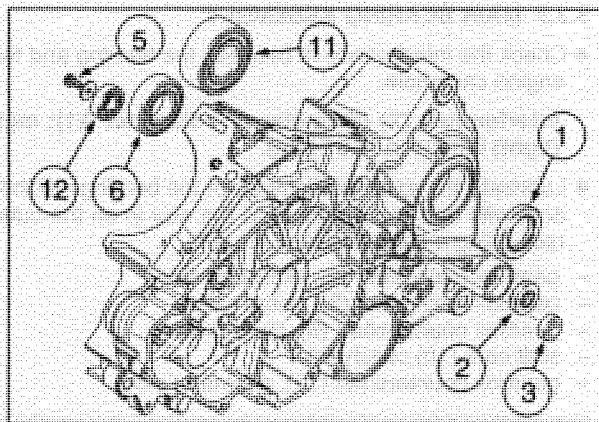

5.3.2 MAIN BEARING DISASSEMBLY

- ◆ Unscrew and remove the M6 flanged-head Allen screws (4) securing the ball bearings.
- ◆ Remove the M6 x 13 flanged-head Allen screw (5).
- ◆ Check to ensure that there is no damage or any sign of grooving or scoring on the bearing lands.
- ◆ In order to remove and insert the ball bearings, heat the engine case to a temperature of approx. 80 – 100 °C (176 – 212 °F).

NOTE In order to avoid damaging the gasket surface, an old engine case gasket should be placed underneath the puller plate.

◆ Remove the main shaft ball bearings (6) with the aid of a universal sleeve puller (7).

◆ Remove the ball bearings using the drift.

- main shaft (8), clutch side;
- countershaft (9), clutch side;
- shift cam (10), clutch side;
- countershaft (11), alternator side.

◆ Remove the shift cam ball bearings (12).

NOTE As a rule, the disassembled ball bearings should be replaced.

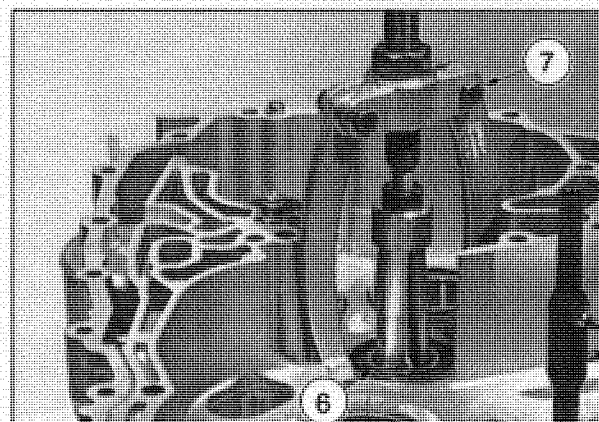
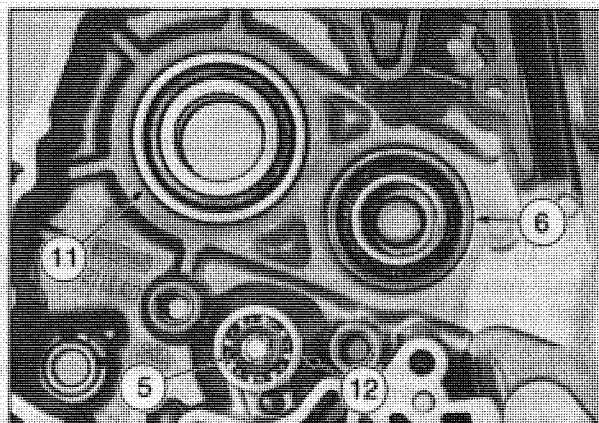
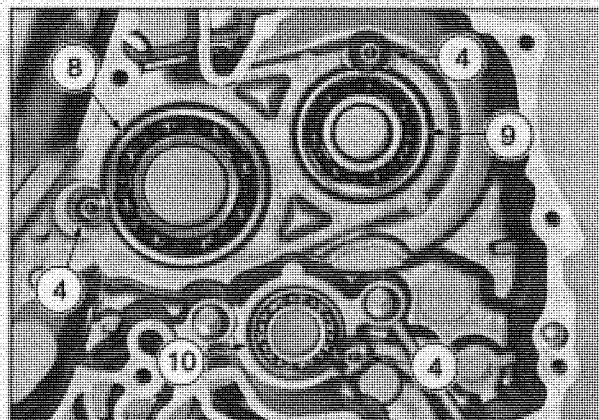

5.3.3 MAIN BEARING ASSEMBLY

◆ Check the interference fit between the bearing and the engine case hole.

Interference (X) (diameter A – diameter A1): min. (tight) 0.0004 in (0.01 mm).

◆ Lubricate the external diameter of the bearings slightly and, with due care, fit them all the way in on the outer race using a suitable assembly drift:

- gearbox main shaft (6), alternator side;
- gearbox main shaft (8), clutch side;
- gearbox countershaft (9), clutch side;
- shift cam (10), clutch side;
- gearbox countershaft (11), alternator side.

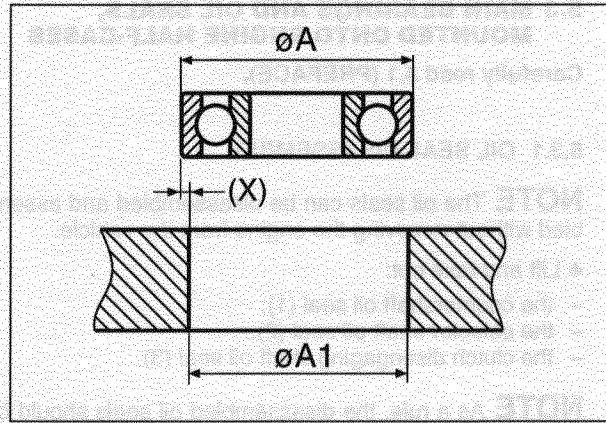

CAUTION

The gasket of the gearbox main shaft ball bearing (6), alternator side, must face outwards.

NOTE As a rule, the disassembled ball bearings should be replaced.

- ◆ Lubricate the internal diameter of the shift cam ball bearing (12), alternator side, slightly and, with due care, fit it all the way in on the inner ring using a suitable assembly drift.
- ◆ Apply LOCTITE® 243 on the screws (4) (5) securing the ball bearings and screw them into the engine case.

Screws tightening torque: 8 ftlb (11 Nm).

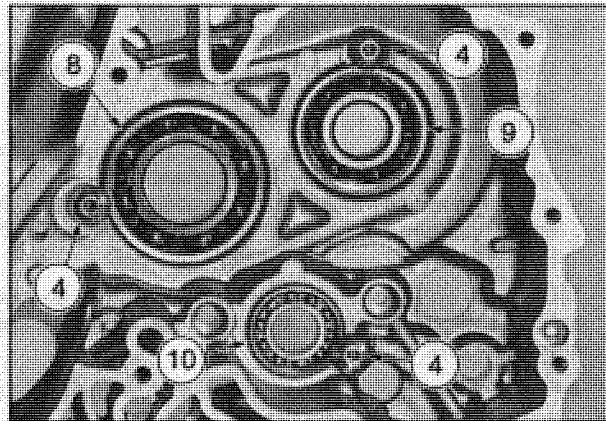

5.3.4 OIL SEAL ASSEMBLY

NOTE Have the appropriate special tool **OPT** available:

- aprilia part# 0877650 (handle for drift) (13);
- aprilia part# 0277680 (countershaft oil seal assembly drift) (14);
- aprilia part# 8140155 (main shaft oil seal-clutch shaft oil seal assembly drift) (15).

NOTE Before assembling the shaft seals, their external diameter must be lubricated slightly. The closed side of the shaft seals must face outwards. Grease the sealing lips.

CAUTION

The oil seal (1) of the countershaft must not touch the inner race of the bearing in any way as this would result in damage.

- ◆ Insert the oil seal (1) flush with the engine case using the assembly drift (14).
- ◆ Insert the shaft seals (2) (3) all the way using the assembly drift (15).

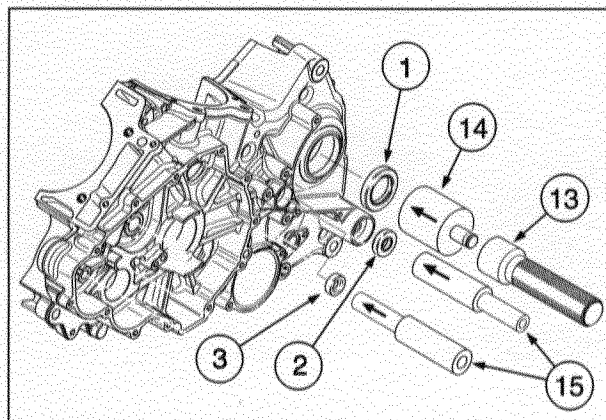
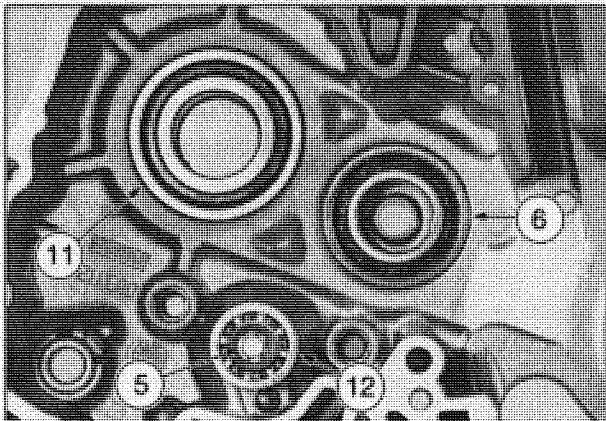

5.4 CRANKSHAFT MAIN BUSHINGS AND LOWER BALANCESHAFT MAIN BUSHINGS

Carefully read 5.1 (PREFACE).

CAUTION

The main bushings should only be replaced by repair shops that possess the appropriate measurement. We strongly suggest that you return engine cases which require main bushing service to:

aprilia USA inc.
110 Londonderry Court, Suite 130
Woodstock, GA 30188
USA
Tel 770 592 2261
Fax 770 592 4878

- ◆ Measure the internal diameter of the crankshaft main bushings (1) in both halves of the engine case.

Crankshaft main bushings (1): wear limit diameter 1.81239 in (46.035 mm).

- ◆ Measure the internal diameter of the lower balancer shaft main bushings (2) in both halves of the engine case.

Lower balancer shaft main bushings (2): wear limit diameter 1.2622 in (32.060 mm).

CAUTION

Take a number of measurements, especially in the direction of the axis of both cylinders. None of the values must exceed the limit value.

NOTE Measure the radial play between the crankshaft main bushings (1) and the journals of the crankshaft, see 5.10 (CRANKSHAFT).

NOTE Measure the radial play between the lower balancer shaft main bushings (2) and the journals of the lower balancer shaft, see 5.13 (LOWER BALANCESHAFT AND LOWER BALANCESHAFT MECHANISM).

- ◆ Check for signs of wear or slipping on the axial thrust-bearing lands (3) (4), for the crankshaft, in both halves of the engine case.
- ◆ Check for signs of wear or slipping on the axial thrust-bearing lands (5) (6), for the lower balancer shaft, in the clutch side engine half-case.

CAUTION

Check the axial play of the crankshaft, see 5.10 (CRANKSHAFT).

Check the axial play of the lower balancer shaft, see 5.13 (LOWER BALANCESHAFT AND LOWER BALANCESHAFT MECHANISM).

5.4.1 DISASSEMBLY

Remove the main bushing by working from inside of the corresponding engine half-case.

- ◆ Use a felt pen to mark the contact surfaces (7) of the main bushings on both halves of the engine case so as to provide an external visual reference.

CAUTION

Do not scratch or engrave any markings.

Follow ►

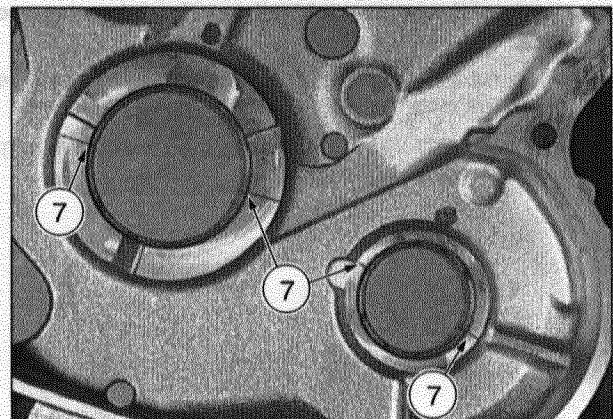
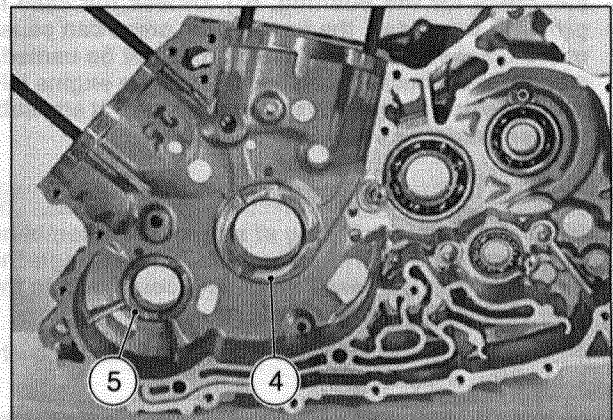
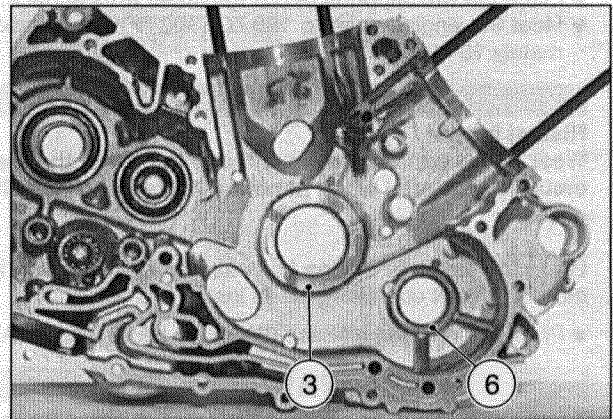
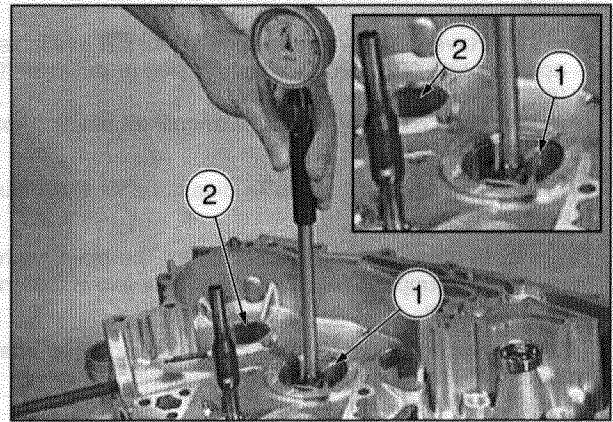

Follow ►

- NOTE** Have the appropriate special tool **OPT** available:
- **aprilia** part# 0277720 (crankshaft sleeve puller drift) (8);
 - **aprilia** part# 8140074 (lower balanceshaft bushing extractor drift) (9).

NOTE Use an hand press to disassemble the main bushings.

NOTE In order to remove (and insert) the main bushings, use two supports (A) to bear the half-case of the engine in question.

The two supports must be made of hard wood and offer smooth surfaces and the following dimensions:

length (L) = 12 in (300 mm);

width (W) = 8 in (200 mm);

height (H) = 2 in (50 mm).

- ◆ Place the two supports (A) on the press work surface.
- ◆ Heat the engine case to 150 °C (302 °F) for approximately 15 minutes.

▲ WARNING

Risk of burns.

Wear heavy leather gloves and use fire-proof thermal insulated material when handling heated engine half-cases.

NOTE Place the engine half-case on its outer side in order to permit operations on its inside.

- ◆ Place the engine half-case (B) on the two supports (A).

▲ WARNING

To support the case against the force exerted by the press, position the two supports (A) near the main bushings which are being serviced. Be careful to allow clearance for the bushing, (C). Unless the case is properly supported, the force of the press can cause micro cracks in the case, which may not be immediately evident, but will subsequently cause engine failure and seizure, with risk of serious accident and subsequent injury or even death.

▲ WARNING

Disassemble one bushing at a time. Disassembling both bushings at the same time may damage the bushings, and the case halves, and could lead to the kind of damage described above.

- ◆ Place the appropriate puller drift (8) or (9) on the bushing to be disassembled.

▲ WARNING

Use the press with great care. Make sure that there are no spectators close to the press. The bush, the case, or parts of the press could fail, causing injury to spectators.

- ◆ Proceed with great caution, using an hand press remove the main bushings from the engine half-case.

NOTE As a rule, the disassembled main bushings should be replaced in pairs.

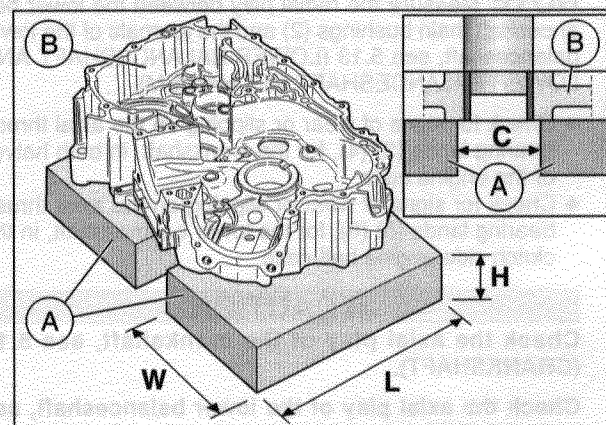
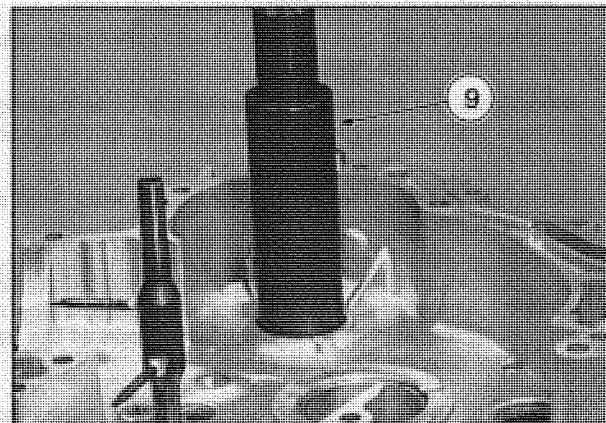
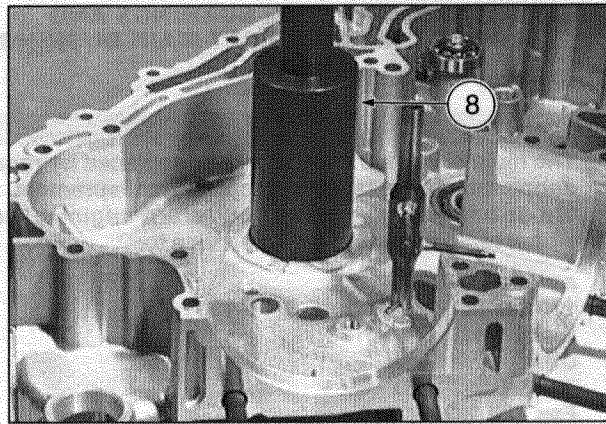

5.4.2 ASSEMBLY

NOTE The main bushings must be mounted inside the engine half-case.

- ◆ Clean the bore of the main bushing housing inside the engine case.
- ◆ Determine the main bushing size group based on the colored markings (10) on the engine case.

CAUTION

The lower main bushing (11) of the crankshaft alternator side is provided with a lubrication hole.

NOTE The size group of the main bushings is also marked with a colored dot.

- ◆ If the colored marking applied on the engine case is no longer clearly legible, calculate the diameter based on the average of a number of different measurements.

CAUTION

Take a number of measurements, especially in the direction of the axis of both cylinders.

CRANKSHAFT		
Bushing bore in the engine half-case	Main bushings marking	Engine half-case marking
Ø 1.9645 – 1.9648 in (49.899 – 49.908 mm)	red	red
Ø 1.9648 – 1.9652 in (49.908 – 49.918 mm)	blue	blue
Ø 1.9652 – 1.9657 in (49.918 – 49.929 mm)	yellow	yellow

LOWER BALANCESHAFT		
Bushing bore in the engine half-case	Main bushings marking	Engine half-case marking
Ø 1.4137 – 1.4141 in (35.909 – 35.918 mm)	red	red
Ø 1.4141 – 1.4145 in (35.918 – 35.928 mm)	blue	blue
Ø 1.4145 – 1.4149 in (35.928 – 35.939 mm)	yellow	yellow

NOTE Have the appropriate special tool **DPT** available:

- aprilia part# 0277725 (crankshaft bushing inserter drift) (12);
- aprilia part# 0277729 (lower balanceshaft bushing inserter drift) (13).
- ◆ Heat the engine case to **approx. 150 °C (302 °F)**.
- ◆ Coat the main bushing and the crankcase bore with **MOLYKOTE® G-N**.

M = MOLYKOTE® G-N.

Follow ►

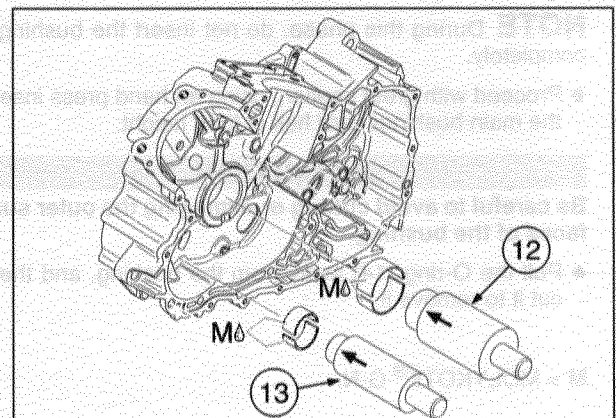
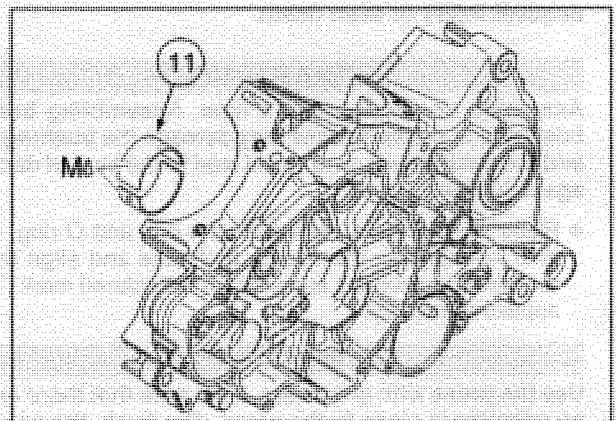
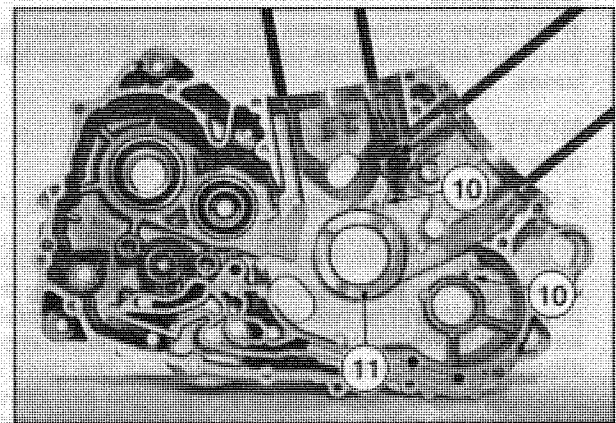
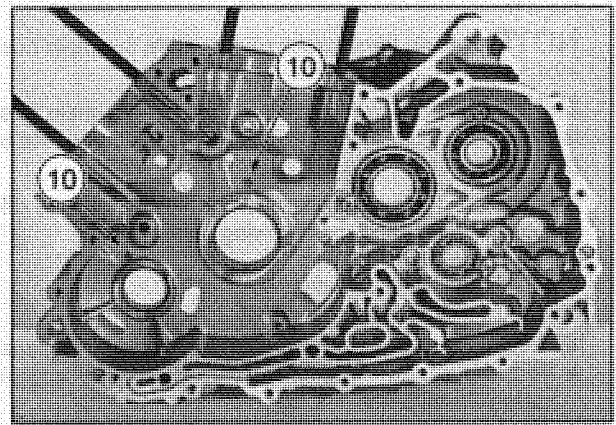

Follow ►

NOTE Use an hand press to assemble the main bushings.

NOTE In order to remove (and insert) the main bushings, use two supports (A) to bear the half-case of the engine in question.

The two supports must be made of hard wood and offer smooth surfaces and the following dimensions:

- length (L) = 12 in (300 mm);
- width (W) = 8 in (200 mm);
- height (H) = 2 in (50 mm).

- ◆ Place the two supports (A) on the press work surface.
- ◆ Heat the engine case to 150 °C (302 °F) for approximately 15 minutes.

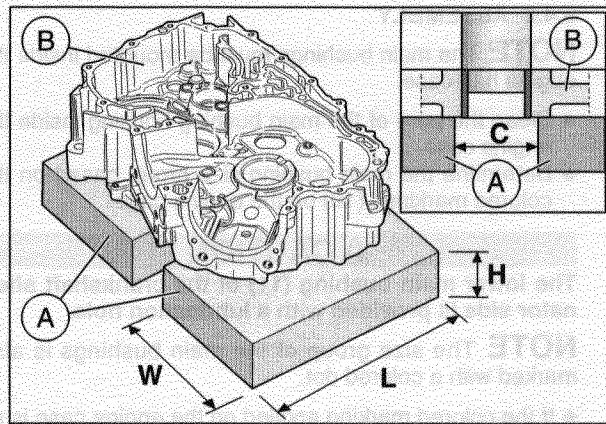

⚠ WARNING

Risk of burns.

Wear heavy leather gloves and use fire-proof thermal insulated material when handling heated engine half-cases.

NOTE Place the engine half-case on its outer side in order to permit operations on its inside.

- ◆ Place the engine half-case (B) on the two supports (A).

⚠ WARNING

To support the case against the force exerted by the press, position the two supports (A) near the main bushings which are being serviced. Be careful to allow clearance for the bushing, (C). Unless the case is properly supported, the force of the press can cause micro cracks in the case, which may not be immediately evident, but will subsequently cause engine failure and seizure, with risk of serious accident and subsequent injury or even death.

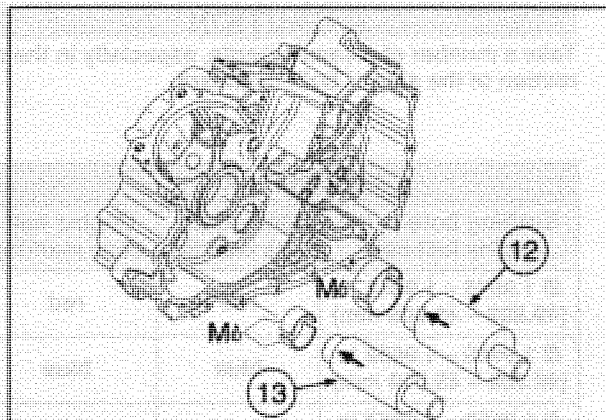

⚠ WARNING

Assemble one bushing at a time. Assembling both bushings at the same time may damage the bushings, and the case halves, and could lead to the kind of damage described above.

- ◆ Place the bushings, complete with drift and O-ring, in their housings in the engine half-case and align the main bushing contact surface with the colored mark (7) applied previously.

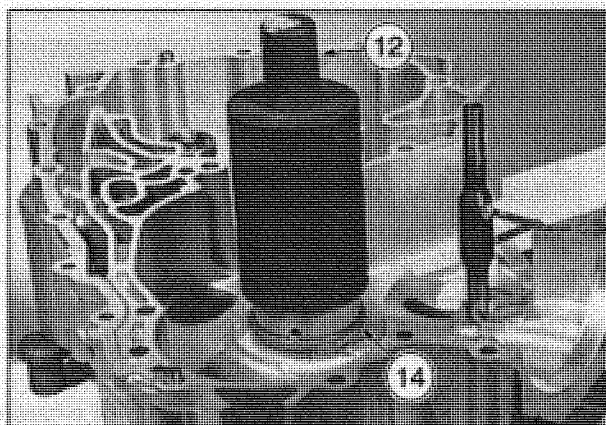

⚠ WARNING

Use the press with great care. Make sure that there are no spectators close to the press. The bush, the case, or parts of the press could fail, causing injury to spectators.

NOTE During this phase, do not insert the bushings completely.

- ◆ Proceed with great caution, using an hand press insert the main bushings until half of their height.

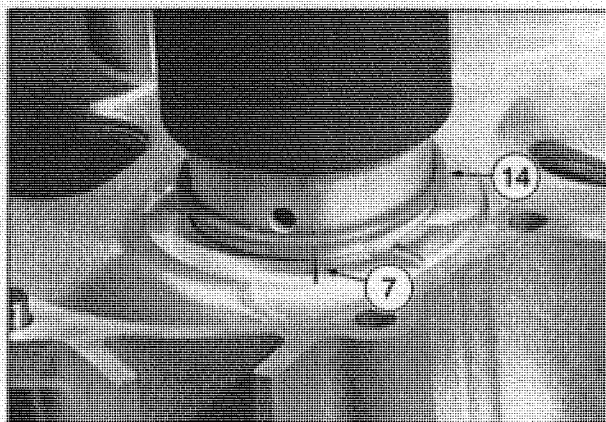

⚠ CAUTION

Be careful to avoid cutting or damaging the outer surfaces of the bushing.

- ◆ Pull the O-ring (14) away from the bushing, and then cut it to remove it.

M = MOLYKOTE® G-N.

Follow ►

Follow ►

- ◆ Proceed with great caution, using an hand press insert the main bushings until the assembly drift (12) or (13) comes into light contact with the engine half-case thrust bearing land (3), or (4), or (5) or (6).
- ◆ The crankshaft main bushings (1) are fitted so that they are 0.0787 in (2.0 mm) below the thrust-bearing lands (3) (4).
- ◆ The lower balanceshaft main bushings (2) are fitted so that they are 0.0591 in (1.5 mm) below the thrust-bearing land (5) (6).

NOTE The lower main bushings of the crankshaft alternator side is provided with a lubrication hole (11).

- ◆ Once assembled, ensure that the lubrication hole (11) in the main bushing is lined up with the hole in the engine case.

CAUTION

Should the main bushings be assembled incorrectly, they must be removed using the disassembly drift as described above, see **DISASSEMBLY**.
Disassembled main bushings may not be reused.

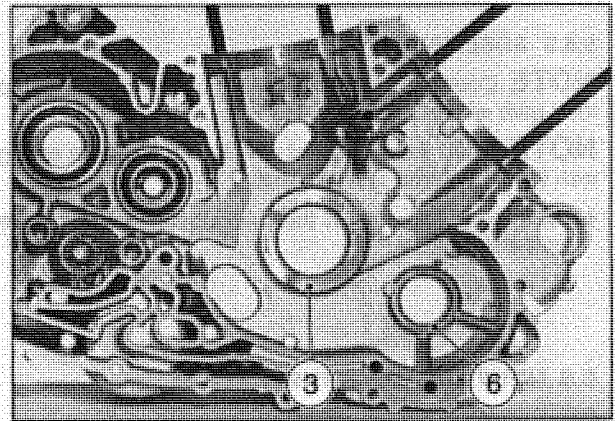
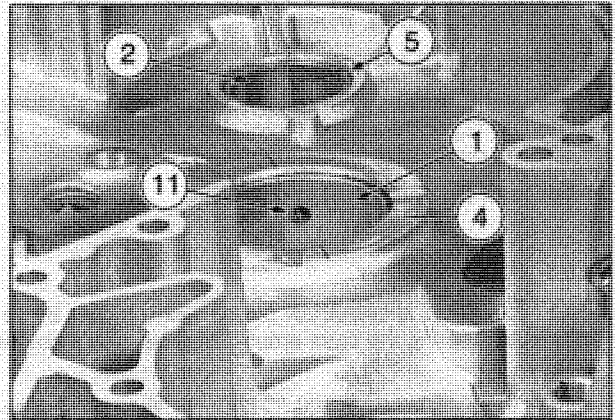

(1) crankshaft main bushing (2) lower balanceshaft main bushing (3) (4) (5) (6) thrust-bearing lands (11) lubrication hole

NOTE The lower main bushings of the crankshaft alternator side is provided with a lubrication hole (11) in the main bushing. Once assembled, ensure that the lubrication hole (11) in the main bushing is lined up with the hole in the engine case.

Use the hand press to insert the main bushings until the assembly drift (12) or (13) comes into light contact with the engine half-case thrust bearing land (3), or (4), or (5) or (6).

Use the hand press to insert the lower balanceshaft main bushings until the assembly drift (12) or (13) comes into light contact with the engine half-case thrust bearing land (5) or (6).

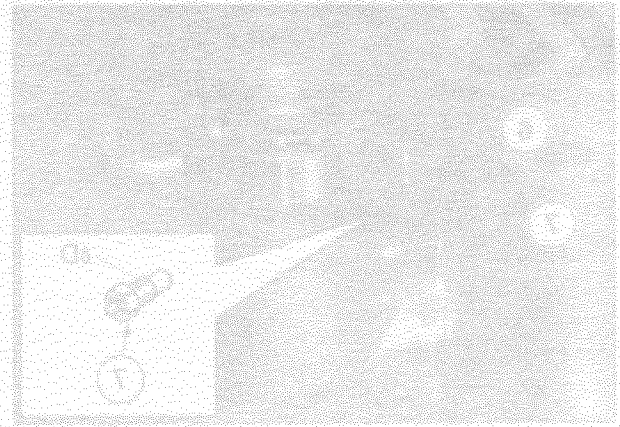

5.5 REPLACING THE ENGINE HALF-CASE CYLINDRICAL PINS

Carefully read 5.1 (PREFACE).

- ◆ Use a micrometer to check the wear of the cylindrical pins (1) (2) of the starter motor drive assembly and (3) coolant pump idler gear.

Wear limit \varnothing 0.3933 in (9.990 mm).

5.5.1 DISASSEMBLY

NOTE Should a cylindrical pin be worn, it may be removed by heating the case around its base with a hot-air gun (4).

- ◆ Heat the area to about 100 °C (212 °F), then pull the cylindrical pin out with pliers, rotating it upwards.

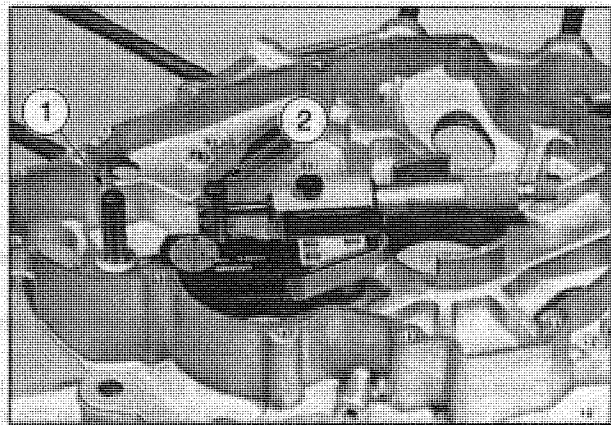

5.5.2 ASSEMBLY

NOTE Coat the cylindrical pin (3) of the coolant pump idler gear with LOCTITE® 648.

NOTE Insert the cylindrical pin (5) of the needle spring with the chamfered part external.

- ◆ Using great care, install the cylindrical pins in the case until they bottom.

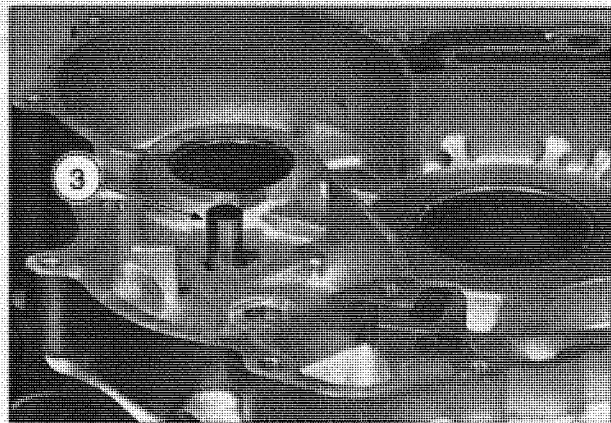

5.6 NEUTRAL GEAR INDICATION

Carefully read 5.1 (PREFACE).

- ◆ Ensure that the contact pin (6) of the contact screw (7) slides smoothly and check the strength of the spring.

CAUTION

The cap on the pin must not display any wear. If it does, replace the contact screw.

If the contact screw (7) is renewed or replaced:

NOTE Apply a couple of drops of LOCTITE® 574 to the threads.

- ◆ Tighten the contact screw (7).

Contact screw tightening torque: 2.9 ftlb (4 Nm).

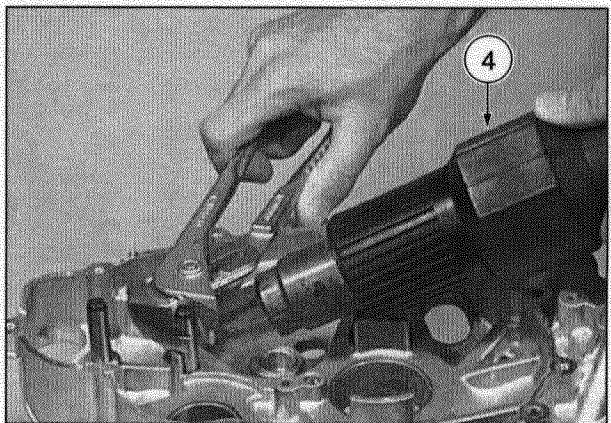

D = LOCTITE® 574.

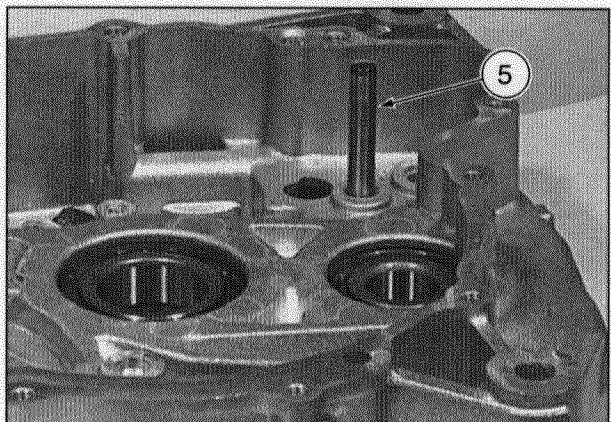
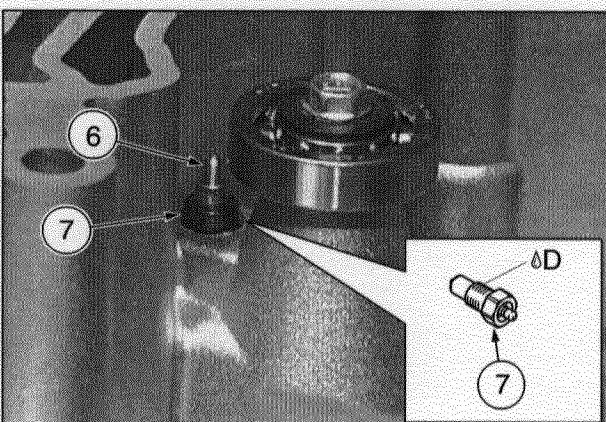

5.7 ASSEMBLING THE ENGINE HALF-CASE

Carefully read 5.1 (PREFACE).

⚠ CAUTION

Should a stud (1) be damaged, it must be replaced.

If the stud (1) is renewed or replaced:

NOTE Apply a couple of drops of LOCTITE® 243 to the threads.

◆ Tighten the stud (1).

Stud tightening torque: 7.2 ftlb (10 Nm).**NOTE** Ensure that both studs are screwed in completely and properly tightened.

◆ Install the jet (2).

◆ Install the M6 Allen screw (3) along with its seal (4).

Allen screw tightening torque: 4.4 ftlb (6 Nm).

◆ Insert the oil filter (5).

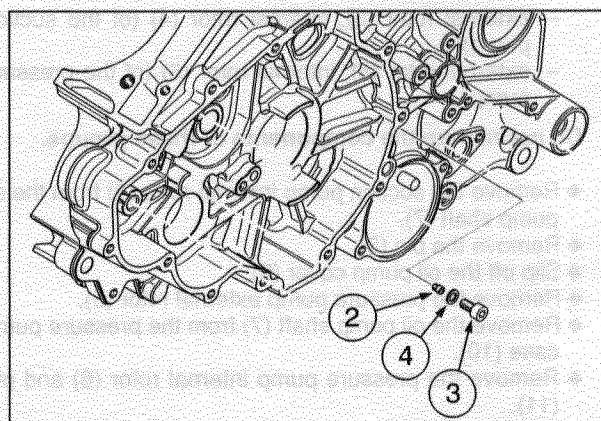
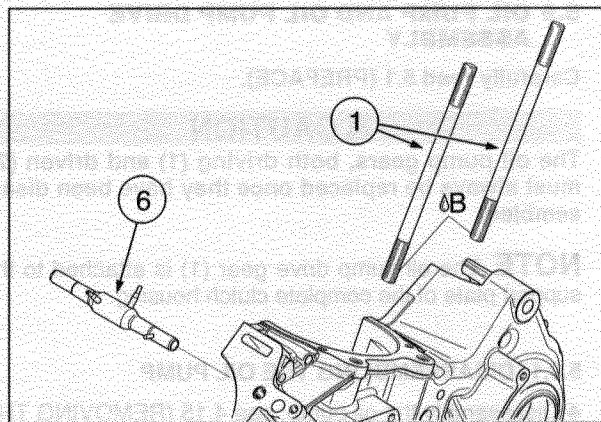
**5.8 COMPLETE OIL-SPRAY PIPE**

Carefully read 5.1 (PREFACE).

5.8.1 DISASSEMBLY

Using a hot-air gun, heat up the case in the area where the oil spray pipe is installed to approximately 100 °C (212 °F). Rotate it up and out of the case using a pair of pliers.

5.8.2 ASSEMBLY**NOTE** There is an oil passage in the engine case. It must be correctly aligned with the oil-spray pipe (6) inlet.**⚠ WARNING**

Failure to correctly align the oil spray pipe and the passage in the engine case can result in engine seizure, with subsequent serious accident and even death.

⚠ CAUTION

Take care not to damage the nozzles (7).

◆ Maintaining the proper position for the oil spray pipe (6), insert it into the alternator side of the engine case (8).

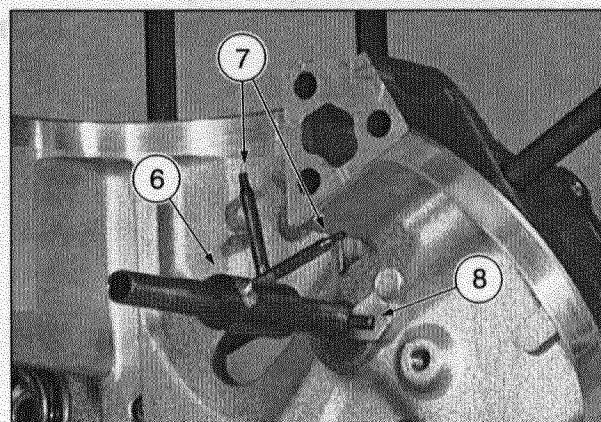
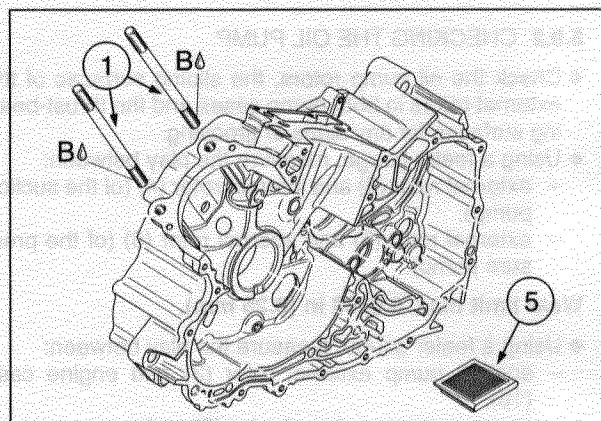
B = LOCTITE® 243.

5.9 OIL PUMP AND OIL PUMP DRIVE ASSEMBLY

Carefully read 5.1 (PREFACE).

CAUTION

The oil pump gears, both driving (1) and driven (2), must always be replaced once they have been disassembled.

NOTE The oil pump drive gear (1) is attached to the support plate of the complete clutch housing.

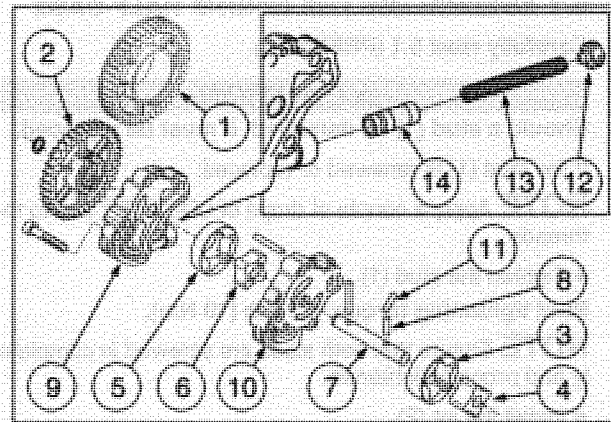

5.9.1 DISASSEMBLING THE OIL PUMP

◆ Disassembly the oil pump, see 4.15 (REMOVING THE OIL PUMP).

NOTE Store, to keep separately, the groups:

- external rotor (3), internal rotor (4) (of the suction pump);
- external rotor (5), internal rotor (6) (of the pressure pump).

Do not mix-up the components of these groups.

- ◆ Remove the suction pump internal rotor (4) from the oil pump shaft (7).
- ◆ Remove the pin (8).
- ◆ Slip off the oil pump cover (9).
- ◆ Remove the pressure pump external rotor (5).
- ◆ Remove the oil pump shaft (7) from the pressure pump case (10).
- ◆ Remove the pressure pump internal rotor (6) and pin (11).
- ◆ Unscrew the plug (12) and remove the pressure release spring (13) and valve (14).

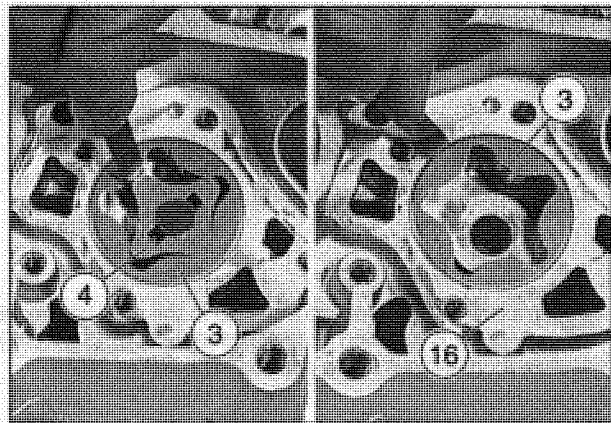

5.9.2 CHECKING THE OIL PUMP

- ◆ Check the oil pump rotors, the sliding surfaces of the external rotors in both pump cases and the thrust-bearing surfaces for any signs of grooving.
- ◆ Using a feeler gauge, measure the play between:
 - external rotor (3) and internal rotor (4) (of the suction pump);
 - external rotor (5) and internal rotor (6) (of the pressure pump).

Wear limit max. 0.0098 in (0.25 mm).

- ◆ Using a feeler gauge, measure the play between:
 - suction pump external rotor (3) and engine case (16);
 - pressure pump external rotor (5) and pressure pump case (10).

Wear limit max. 0.0098 in (0.25 mm).

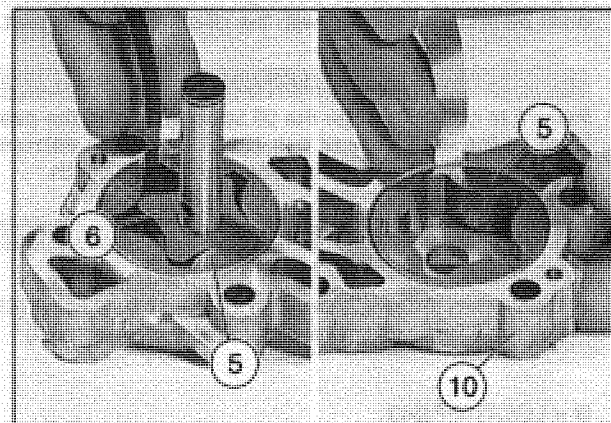

Follow ►

Follow ▶

- ◆ Measure the end play (17) of the rotors.

Wear limit max. 0.0059 in (0.15 mm).

NOTE If either of the wear limits is exceeded, the defective component must be replaced.

- ◆ Ensure that the pressure relief valve (14) slides freely in the oil pump cover (9).
- ◆ Check the pressure relief valve (14) and oil pump cover (9) for signs of wear:
 - pressure relief valve (14),
wear limit (18) min. \varnothing 0.3927 in (9.975 mm);
 - oil pump cover (9),
wear limit (19) max. \varnothing 0.3950 in (10.035 mm);
 - pressure relief spring (13),
minimum length of the spring (20) when not compressed: 2.2 in (56.0 mm).

NOTE Apply a couple of drops of LOCTITE® 648 to the thread of the cap (12).

- ◆ Install the cap (12).

NOTE It should be screwed in until it is 0.078 in (2 mm) below the surface of its recess.

- ◆ Secure the cap by center punching at four diametrically opposed points (21).

C = LOCTITE® 648.

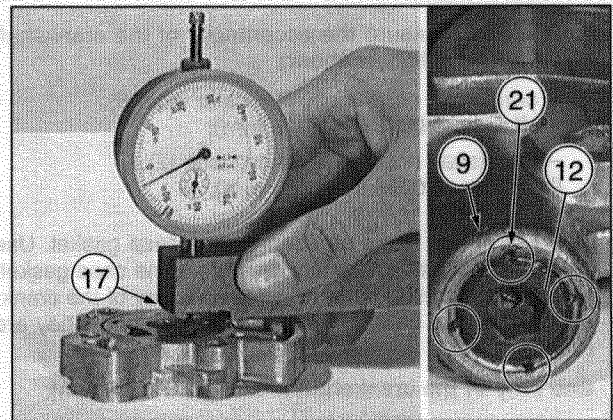
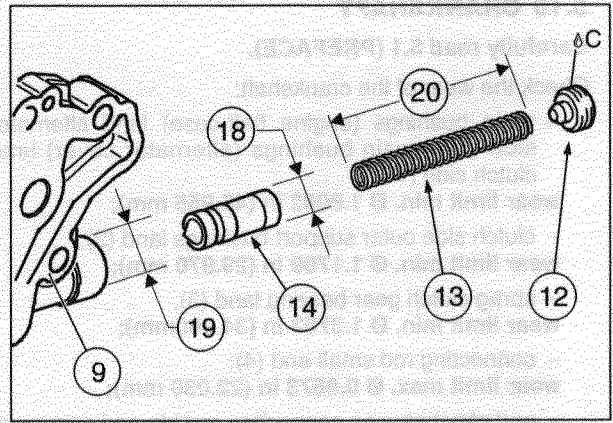

5.10 CRANKSHAFT

Carefully read 5.1 (PREFACE).

Check the wear of the crankshaft:

- main bushings (engine half-case) land alternator side (1A), main bushings (alternator cover) land clutch side (1B),
wear limit min. \varnothing 1.8092 in (45.955 mm);
- clutch side outer support bushings land (2),
wear limit min. \varnothing 1.1799 in (29.970 mm);
- sprag clutch gear bearing land (3),
wear limit min. \varnothing 1.3763 in (34.960mm);
- connecting rod small end (4);
wear limit max. \varnothing 0.8673 in (22.030 mm);
- end play between connecting rod big end and crank pin (5);
wear limit max. 0.023 in (0.60 mm);

NOTE Measure the eccentricity of the crankshaft between centers as shown.

- crankshaft eccentricity alternator side (6);
limit max. 0.0008 in (0.020 mm);
- crankshaft eccentricity clutch side (7);
limit max. 0.0008 in (0.020 mm).

NOTE Never reuse an used engine case gasket. Use only new, original equipment **aprilia** engine case gasket. Use a dial gauge to determine the end play of the crankshaft in the two halves of the engine case once they are assembled.

End play of the crankshaft max. 0.02 in (0.5 mm).

- ◆ Using a dial gauge, evaluate the clearance (8) in the bottom end of each of connecting rods.

Wear limit: max. 0.002 in (0.060 mm).

- ◆ Determine the radial play of both sides (1A) (1B) of the crankshaft. To do this, you must temporarily assemble the crankcase halves and install the crankshaft. Use a light machine oil on the bearing lands.

Max. permissible radial play 0.002 in (0.060 mm).

CAUTION

If the max. permissible radial play is exceeded, the worn part must be replaced.

The radial play may be determined by measuring: the crank pins diameter (1A) (1B) and the internal diameter of the corresponding main bushings and then subtracting the crank pin diameter from the corresponding main bushing diameter.

- ◆ Measure the main bushing diameter, see 5.4 (CRANKSHAFT MAIN BUSHINGS AND LOWER BALANCE-SHAFT MAIN BUSHINGS).
- ◆ Measure the radial play of the support bushings (2).

Permissible radial play max. 0.0025 in (0.065 mm).

The radial play may be determined by measuring: the crank pin diameter (2) and the internal diameter of the support bushing and then subtracting the crank pin diameter from the support bushing diameter.

- ◆ Measure the support bushing diameter, see 4.11 (REMOVING THE CLUTCH COVER).

CAUTION

If the max. permissible radial play is exceeded, the worn part must be replaced.

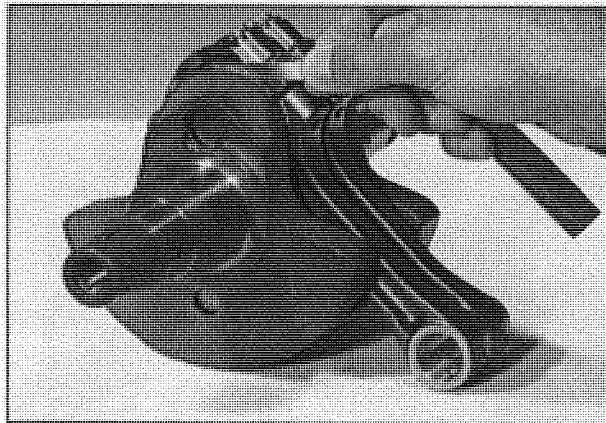
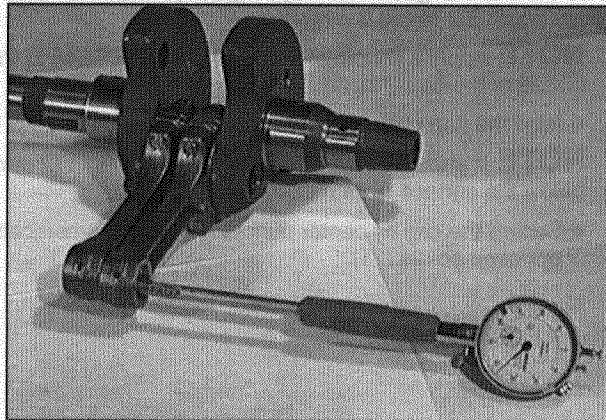
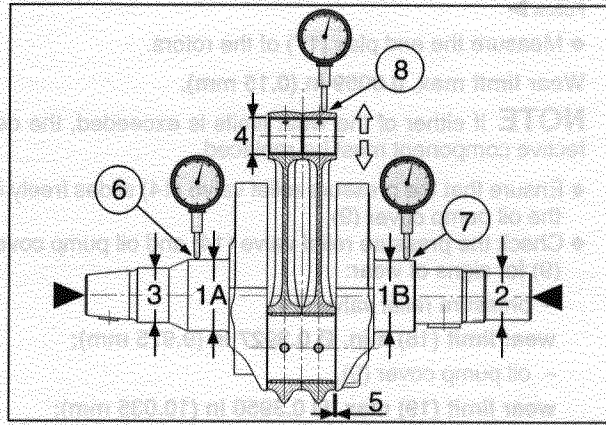

Follow ▶

Follow ►

The following components must all be checked for wear or damage:

- ◆ Key (9) and key seat in the crankshaft.
- ◆ Discoloration of any bearing housing.
- ◆ Tapered surface (10) of the crankshaft on the alternator side.
- ◆ Clean any LOCTITE® residues from the thread (11) and inspect to ensure that it is perfect condition.
- ◆ Check the small end bushing for correct installation and centering.

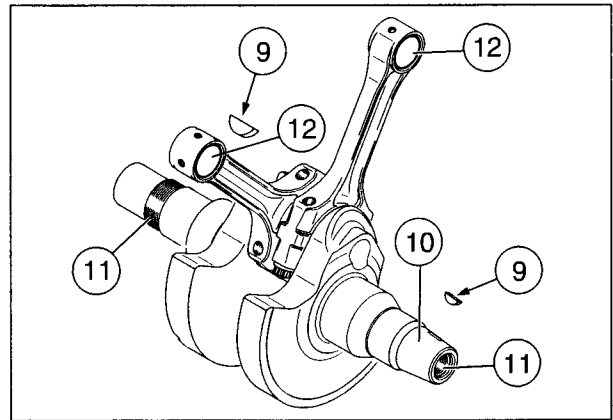

5.11 DISASSEMBLING THE CONNECTING RODS

Carefully read 5.1 (PREFACE).

⚠ CAUTION

Before disassembling the connecting rods (1) and rod caps (2), mark them so they are refitted in the same position (cylinder "1" and "2") and with the same direction of rotation.

- ◆ Unscrew and remove the M10x1 connecting rod bolts (3) and remove the rod cap (2) by tapping lightly with a plastic mallet.
- ◆ Remove the connecting rod bolts with the rod cap (2), and connecting rod (1).
- ◆ Clean the crankshaft lubrication holes.
- ◆ Check the bushings (4) for signs of wear, distortion and discoloration.
- ◆ Check the connecting rod big end for wear, distortion, or fretting:
 - connecting rod pins (5);
 - wear limit min. \varnothing 1.6527 in (41.98 mm);
 - connecting rod big end (6);
 - wear limit max. \varnothing 1.6555 in (42.050 mm).

⚠ CAUTION

To measure the diameter of the connecting rod big end, replace the rod cap (2) and rod bolts (3). Tighten the bolts (3) to the appropriate torque, see 5.12 (REPLACING AND INSTALLING THE CONNECTING RODS). Use a torque wrench or dial gauge, and a 12 mm socket.

NOTE None of the measurements may exceed the limit value. If the connecting rod is determined to be worn or distorted, it must be replaced complete, with rod cap and bolts.

- ◆ Measure the radial play of the connecting rod big end (6).

Wear limit max. \varnothing 0.0028 in (0.070 mm).

NOTE The radial play of the crankshaft is calculated by subtracting the diameter of the crank pin from the diameter of the bearings.

NOTE The radial clearance may also be calculated using plasti-gauge.

If plasti-gauge is used, the connecting rod must not be moved.

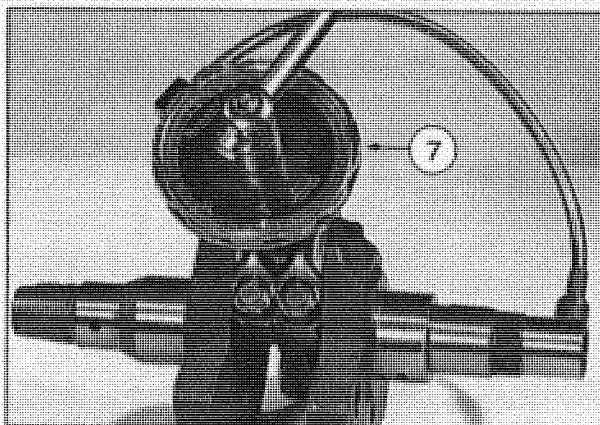
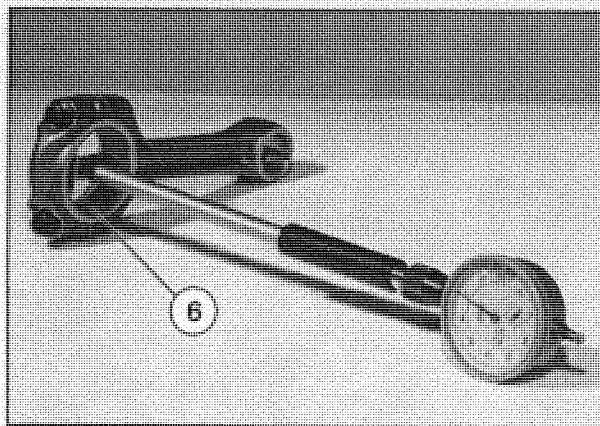
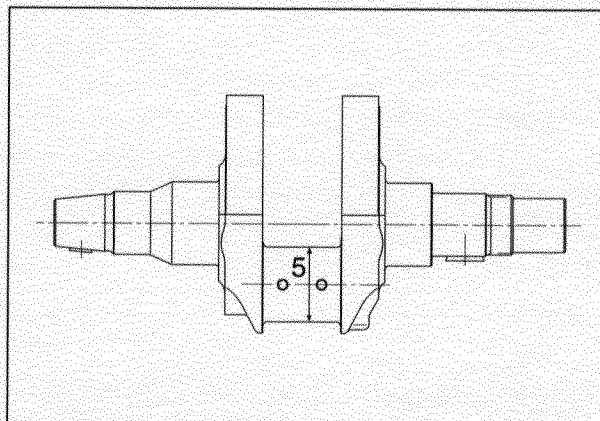
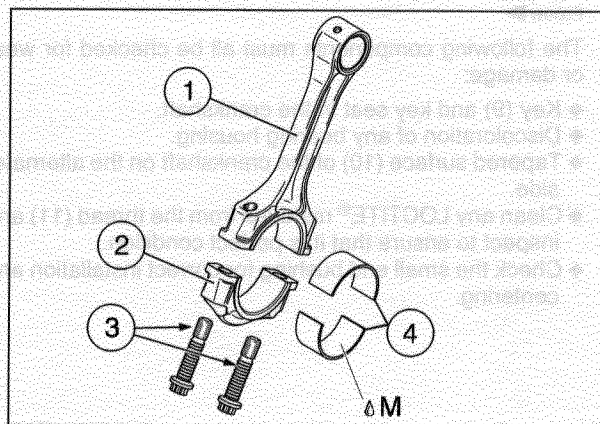

5.12 REPLACING AND INSTALLING THE CONNECTING RODS

Carefully read 5.1 (PREFACE).

NOTE Complete connecting rods are supplied as spare parts with all three size rod bearing inserts (see table). The bearing halves are marked, according to size, in red, blue and yellow (4).

- ◆ Install the minimum thickness (red) bearing halves in the connecting rod (1) and the rod cap (2), taking care to place them correctly (3). Line the bushings up by placing the mating surface of the rod and the rod cap against a surface plate.
- ◆ Install the connecting rod and rod caps on the crank pin so that the two reference points (5) and part number (6) coincide on the two connecting rods.

CAUTION

Correctly torquing the rod cap bolts requires the use of both a torque wrench and protractor gauge (8), see the figure, with a 12 mm socket.

- ◆ Tighten the rod caps (2) using the old bolts (7) in three stages.

The first pre-tightening stage:

- tighten the two bolts to a torque of 1.4 ftlb (2 Nm).

Second tightening stage:

- tighten the two bolts to a torque of 21.7 ftlb (30 Nm).

Third (final) tightening stage:

- further turn each bolts 70°.

- ◆ Measure the radial play of the connecting rod big end using a dial gauge (9).

Radial play 0.0008 – 0.0018 in (0.020 – 0.045 mm).

If the radial play is greater than 0.0018 in (0.045 mm), the bearings of the size corresponding to the colors blue or yellow must be chosen based on the following table, and must be inserted in place of the red bearings.

Bearing color	Thickness
Red	0.0579 – 0.0581 in (1.471 – 1.476 mm)
Blue	0.0581 – 0.0583 in (1.476 – 1.481 mm)
Yellow	0.0583 – 0.0585 in (1.481 – 1.486 mm)

- ◆ Unscrew the bolts (7).
- ◆ Lubricate the bearing halves and the crank pin.

NOTE Use new M10x1 bolts (7) only.

- ◆ Lubricate the bearing lands of the heads of the new bolts (7).

CAUTION

Correctly torquing the rod cap bolts requires the use of both a torque wrench and protractor gauge (8), see the figure, with a 12 mm socket.

- ◆ Fasten the rod cap (2) in the three stages described above using the two new bolts (7).
- ◆ Measure the radial play of the connecting rod big end using a dial gauge (9).

Radial play 0.0008 – 0.0018 in (0.020 – 0.045 mm).

- ◆ Ensure that the connecting rods are free to turn completely around the crank pin.

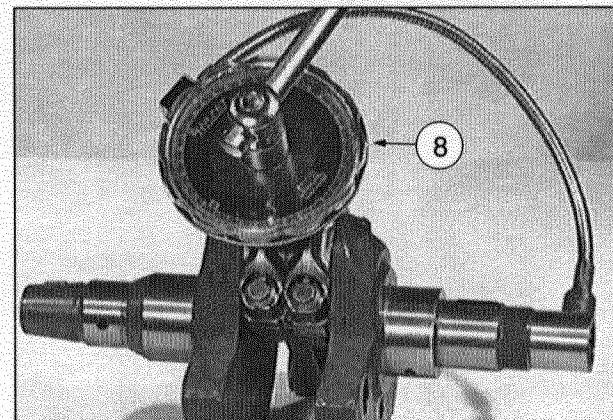
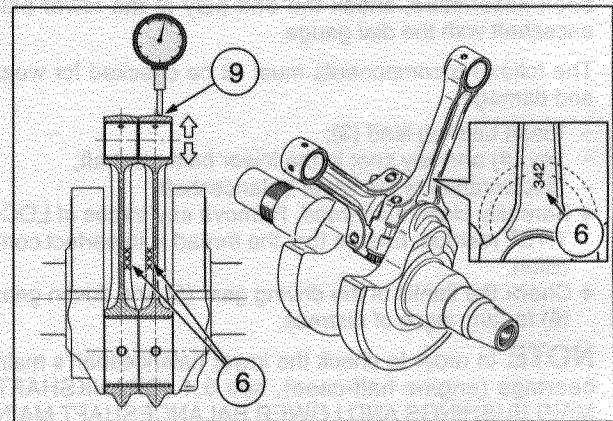
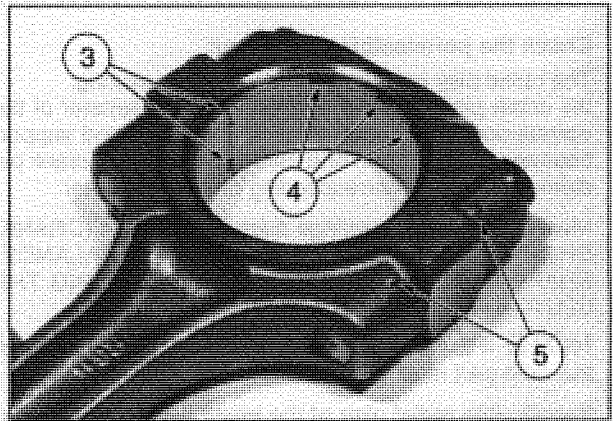
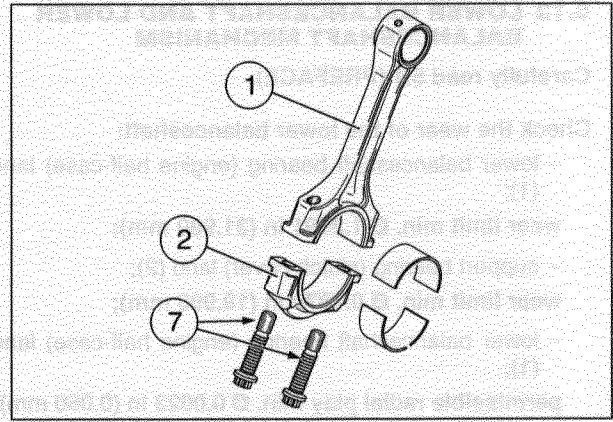

5.13 LOWER BALANCESHAFT AND LOWER BALANCESHAFT MECHANISM

Carefully read 5.1 (PREFACE).

Check the wear of the lower balancershaft:

- lower balancershaft bearing (engine half-case) land (1);
wear limit min. \varnothing 1.2591 in (31.980 mm);
- support bearing (clutch cover) land (2);
wear limit min. \varnothing 0.7870 in (19.990 mm);
- lower balancershaft bearing (engine half-case) land (1);
permissible radial play min. \varnothing 0.0023 in (0.060 mm);
- support bearing (clutch cover) land (2);
permissible radial play min. \varnothing 0.0023 in (0.060 mm).

Check the permissible radial play:

The radial play may be determined by measuring: the crank pins diameter and the internal diameter of the corresponding bearings (engine half-case) and support bearings (clutch cover) and then subtracting the crank pin diameter from the corresponding bearing diameter.

Measure the main bearings diameter, see 5.4 (CRANKSHAFT MAIN BUSHINGS AND LOWER BALANCESHAFT MAIN BUSHINGS) and 4.11 (REMOVING THE CLUTCH COVER).

NOTE If the max. permissible radial play is exceeded, the worn part must be replaced.

Permissible radial play of the lower balancershaft max. 0.012 in (0.30 mm).

NOTE Once the two halves of the engine case have been assembled, check the end play of the lower balancershaft with the dial gauge.

The following components must all be checked for wear and damage:

- thrust bearing land (3);
- key (4) and key seat in the lower balancershaft;
- discoloration of the lower balancershaft.
- ◆ Carefully clean the thread. Remove any traces of LOC-TITE® residue. Ensure that the thread is in perfect condition.
- ◆ Check the flanks of the driving gear (5) and driven gear (6) for any signs of distress.

NOTE In order to check the lower balancershaft's main bearings (engine half-case), see 5.4 (CRANKSHAFT MAIN BUSHINGS AND LOWER BALANCESHAFT MAIN BUSHINGS). In order to check the lower balancershaft's support bearings (clutch side), see 4.11 (REMOVING THE CLUTCH COVER).

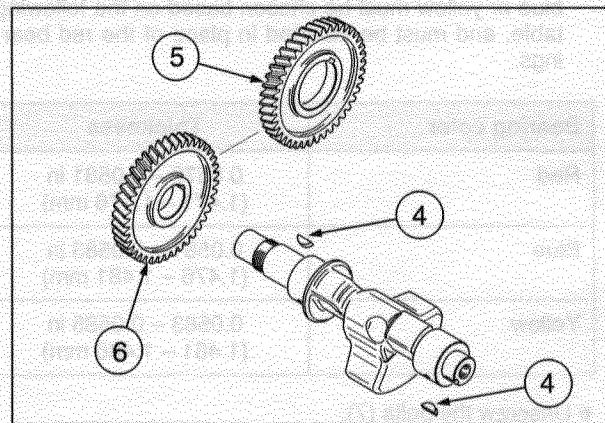
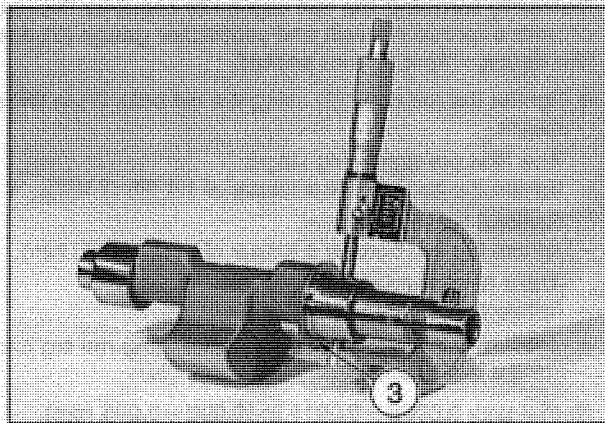
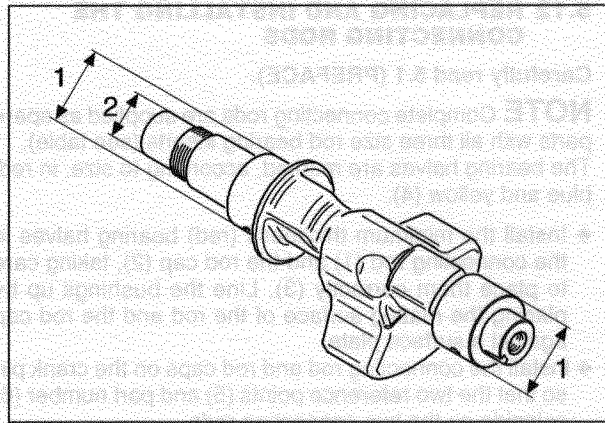

5.14 GEARBOX

Carefully read 5.1 (PREFACE).

CAUTION

When disassembling the gearbox, arrange the disassembled components in order as you take them apart to ensure that you are able to reassemble and install them correctly. Never reuse a snap ring. Snap rings must always be replaced once they are removed from a shaft.

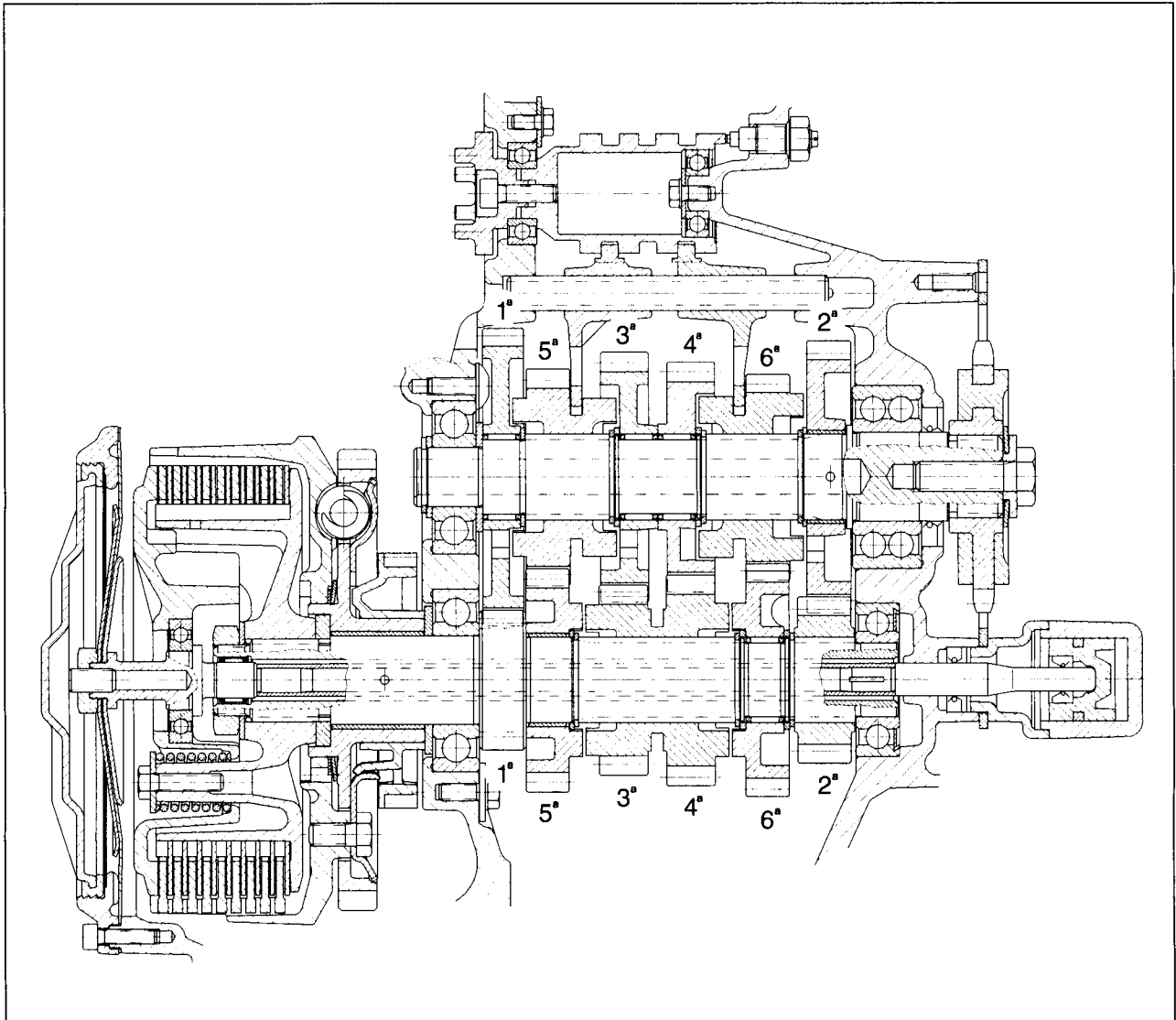

5.14.1 TAKING THE GEARBOX APART

Countershaft

Use snap ring pliers to remove the circlips (4).

- ◆ Remove the gears from the countershaft, starting with the free gear of 1st gear (1) and then moving on to the shim washers (2), roller cages (3), circlips (4) and shim rings (5).

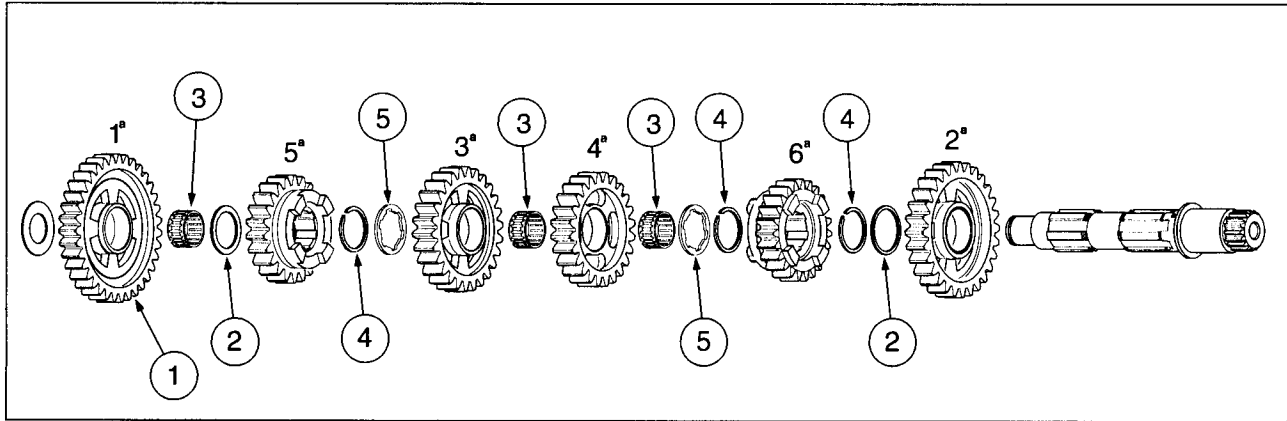

Main shaft

Use snap ring pliers to remove the circlips (7).

- ◆ Remove the gears from the main shaft, starting with the tied gear of 2nd gear (6) and then moving on to the circlips (7), shim rings (8), the roller bearing (9) and shim washer (10).

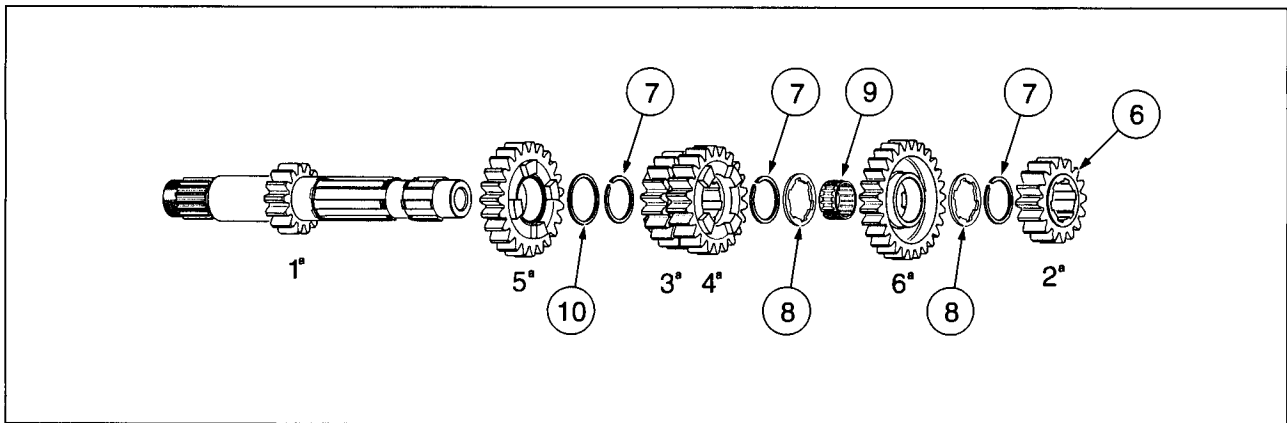

5.14.2 CHECKING

◆ Check the following components for wear:

CAUTION

Never reuse the roller bearings (3) (9). The roller bearings (3) (9) must be replaced every time they are removed.

– check the flanks (11) of the gears for any distress.

NOTE Small areas of discoloration and very small pits are acceptable up to a maximum of approximately 0.5% (½ of 1%) of the tooth surface area.

NOTE Should the flanks of the teeth be worn, the damaged gear and its mating gear must be replaced as a set. Should the dogs or mating recesses be worn, both gears must again be replaced as a set.

- dogs (12) and recesses (13) of all gears;
- condition of shaft splines (14) of main shaft and countershaft;
- condition of splines (15) of all sliding gears;
- check for smooth and effortless lateral movement of the sliding gears (16), (17) on the countershaft and sliding gears (18), (19), (20) on the main shaft.
- check for any sign of damage, grooving or scoring of the bore (21) of the freely rotating gears;
- spline (22) of the countershaft sprocket;
- grooves for circlips (23) on the main shaft and countershaft. The edges of the grooves must be sharp, and not worn round.

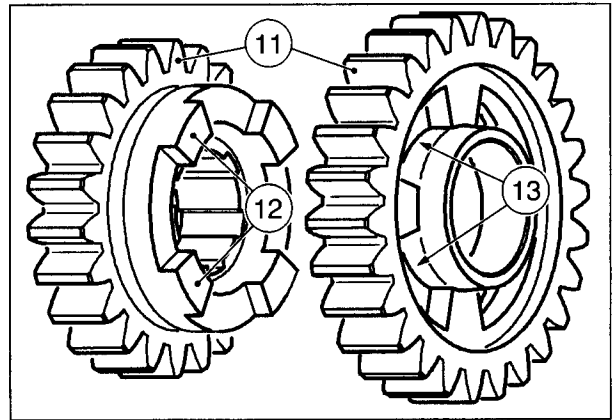

Follow ►

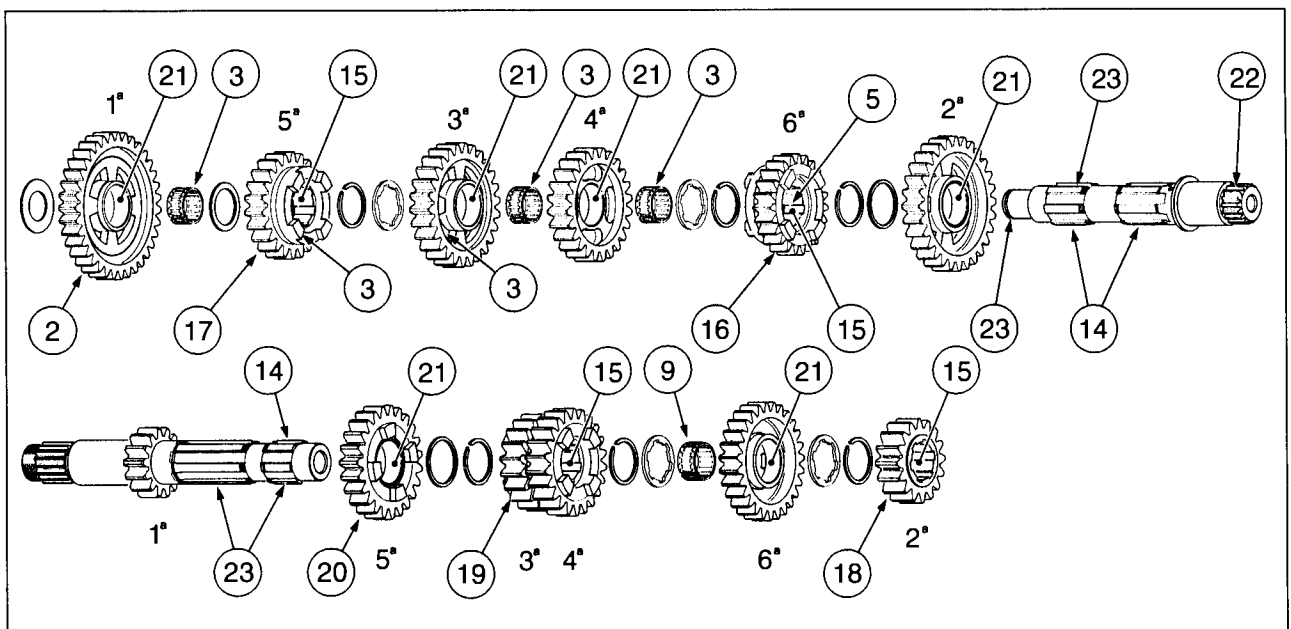

Follow ►

◆ Check the bearing lands of countershaft for wear:

- land (24) wear limit min. diam. 0.7863 in (19.972 mm);
- land (25) wear limit min. diam. 1.7776 in (29.915 mm);
- land (26) wear limit min. diam. 1.1429 in (29.030 mm);
- land (27) wear limit min. diam. 0.9833 in (24.978 mm);
- land (27A) wear limit 0.9833 in (24.978 mm).

◆ Check the bearing lands of main shaft for wear:

- land (28) wear limit diam. 1.1797 in (29.965 mm);
- land (29) wear limit diam. 0.9831 in (24.972 mm);
- land (30) wear limit diam. 1.1429 in (29.030 mm);
- land (31) wear limit diam. 0.9833 in (24.972 mm).

◆ Check the eccentricity (32) of all lands of main shaft and countershaft.

- for all lands permissible eccentricity max diam. 0.0008 in (0.02 mm);

◆ Check for any sign of damage, grooving, or scoring on all of the bearing lands.

◆ Check the internal diameter (33) of the freely rotating of 1st, 3rd, 4th and 6th gear.

Wear limit max. diam. 1.1426 in (29.022 mm).

◆ Check the internal diameter (34) of the freely rotating of 2nd and 5th gear.

Wear limit max. diam. 1.1467 in (29.125 mm).

◆ Ensure that the lubrication hole (35) of the countershaft is clear.

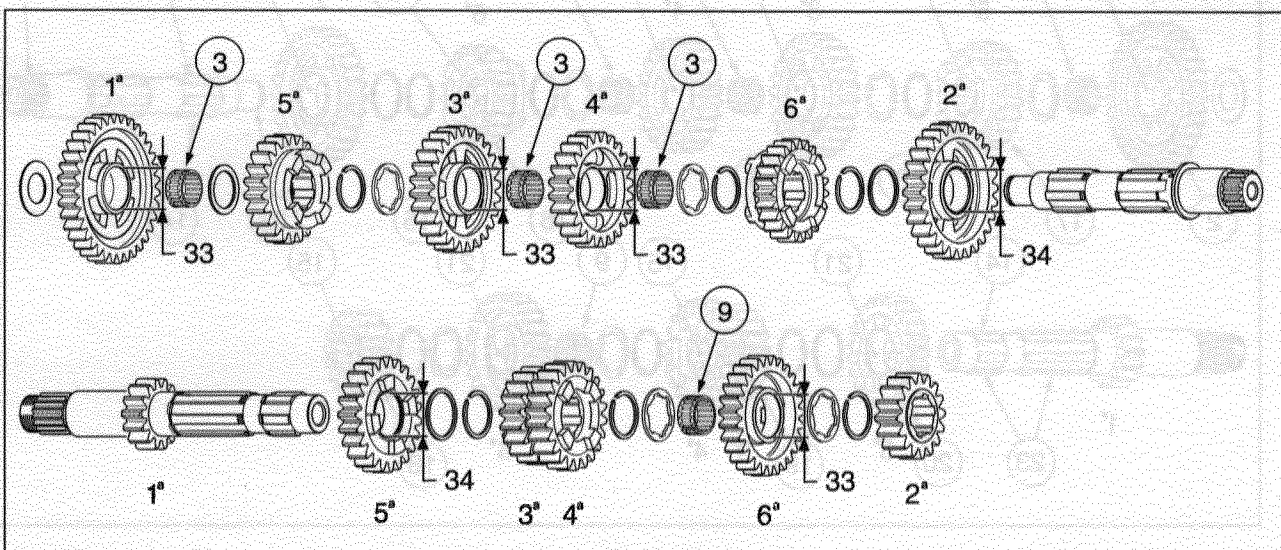
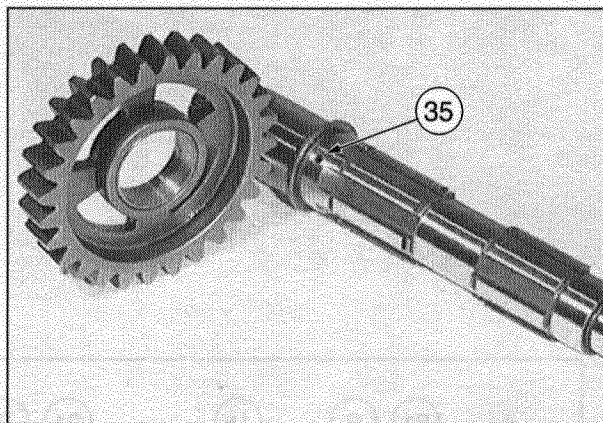
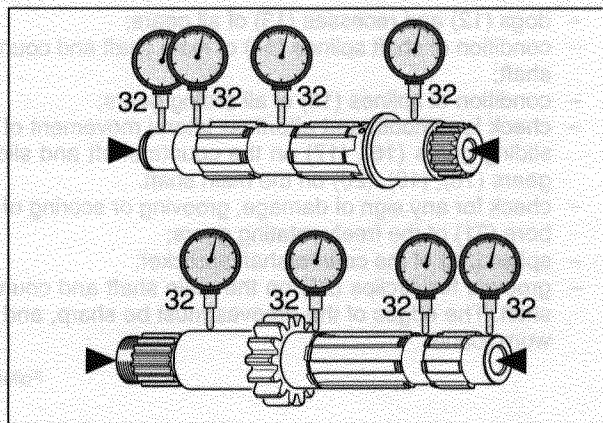
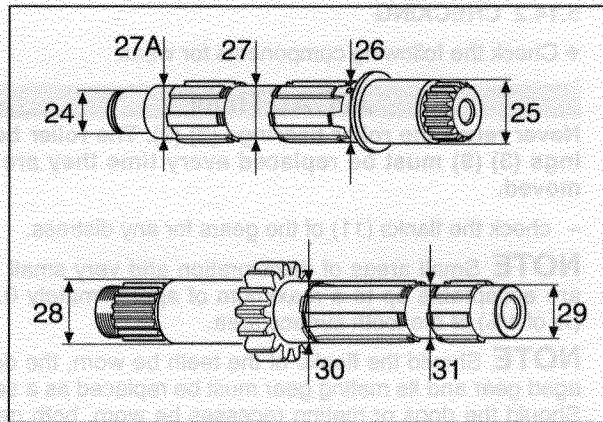

5.14.3 ASSEMBLY

- ◆ Oil the countershaft, main shaft, gearbox gears and roller bearings lightly.
- ◆ Reassemble the gears on both shafts, in the reverse order of disassembly, see 5.14.1 (TAKING THE GEARBOX APART).
- ◆ Fit the circlip, using special circlip pliers.

▲ WARNING

Never reuse circlips. Circlips must be replaced every time they are removed. Stretch the circlip ends far apart just enough to slide the circlip onto the shaft. If the circlip is stretched too much, it will not properly retain the gears on the shaft, which could lead to seizure, and subsequent accident with serious injury or even death. Ensure that all circlips are properly and snugly installed in their appropriate grooves.

- ◆ Once the two gearbox shafts have been assembled, ensure that the gears turn smoothly.

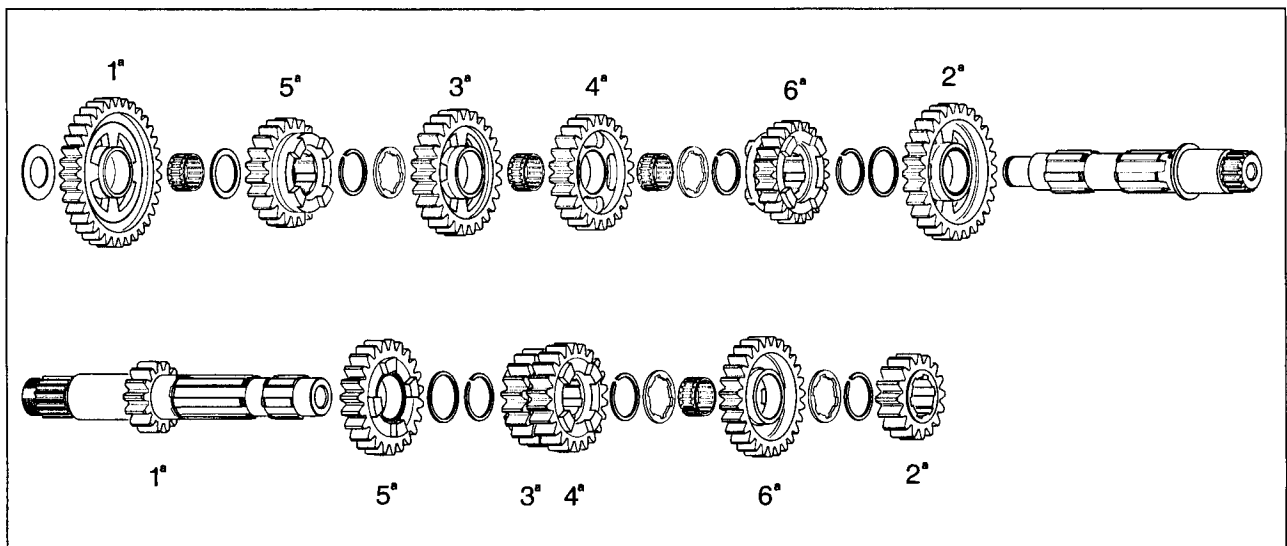
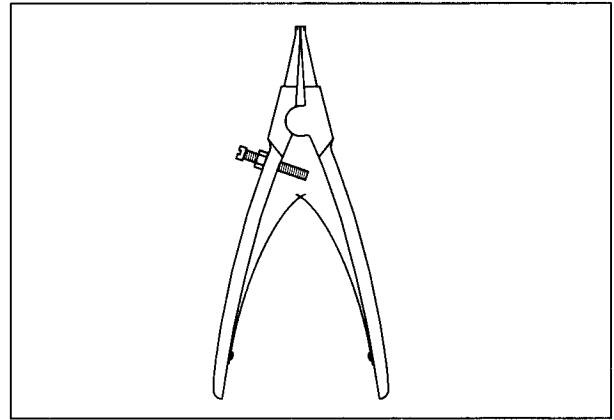

5.15 GEAR SELECTION

Carefully read 5.1 (PREFACE).

- ◆ Check the end play (1) of the gearshift forks inside the corresponding grooves in the sliding gears.

Wear limit max. 0.006 in (0.15 mm).

NOTE If the wear limit is exceeded, you must determine which component needs replacing by checking the gearshift forks and sliding gears.

- ◆ Width of the groove (2) of the sliding gears.

Wear limit max. 0.171 in (4.35 mm).

- ◆ Check the wear on the chromium-plated fingers (3) of the gearshift forks.

Wear limit max. 0.156 in (3.950 mm).

NOTE If the finish is worn through, replace the fork.

- ◆ Check the diameters (4) of the gearshift fork guide pins.

Wear limit min. \varnothing 0.230 in (5.850 mm).

- ◆ Check the eccentricity of the two fork shafts (5).

Max. permissible eccentricity 0.0008 in (0.02 mm).

- ◆ Check the wear of the ratchet gear in the area in which it comes into contact with the index plate pins.

Wear limit (6): visual inspection.

- ◆ Check the eccentricity of the selector shaft (7) and also check for any signs of rolling on the sliding surface of the shaft sealing ring.

Max. permissible eccentricity 0.001 in (0.25 mm).

- ◆ The roller (8) of the detent lever must turn freely.
- ◆ Check the wear of the guide tracks (9) of the shift cam.

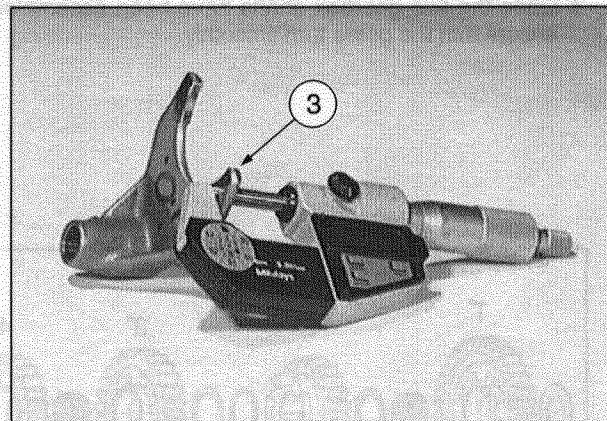
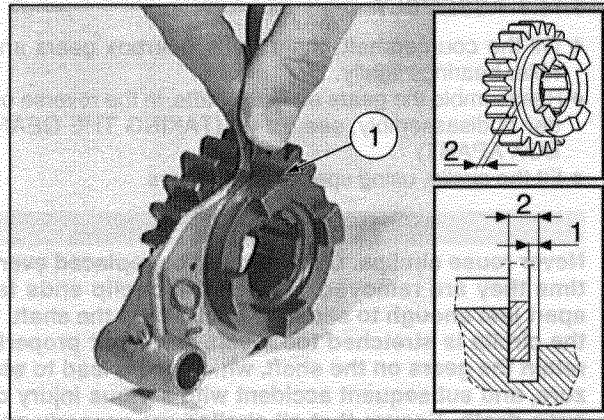

5.16 CLUTCH (VERSIONS)

NOTE There are different clutch versions.

For information regarding the components of the clutch, refer to the specific spare parts catalogue, according to the vehicle model on which the engine is installed, see 0.4.2 (SPARE PARTS CATALOGUE).

For the clutch check, see 5.17 (CHECKING THE CLUTCH).

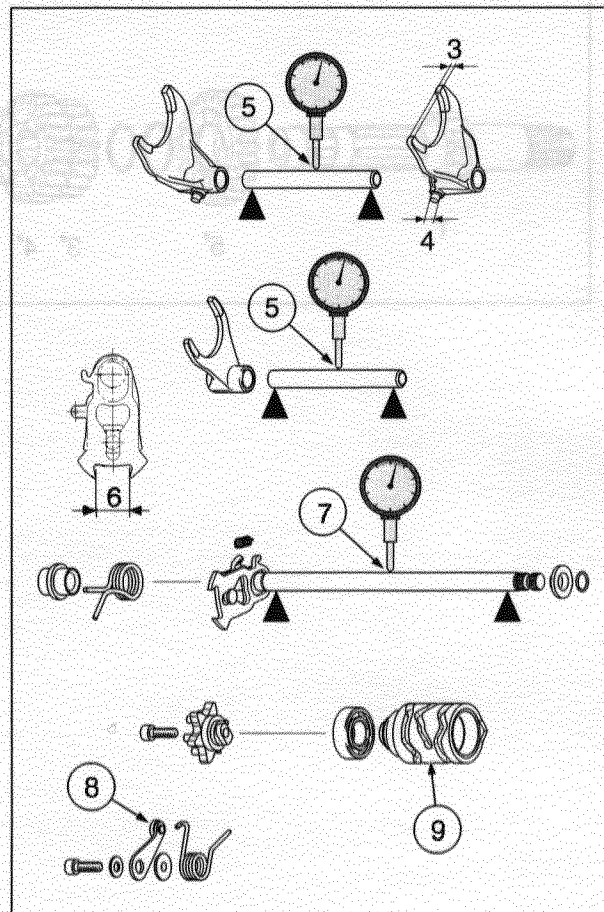

5.17 CHECKING THE CLUTCH

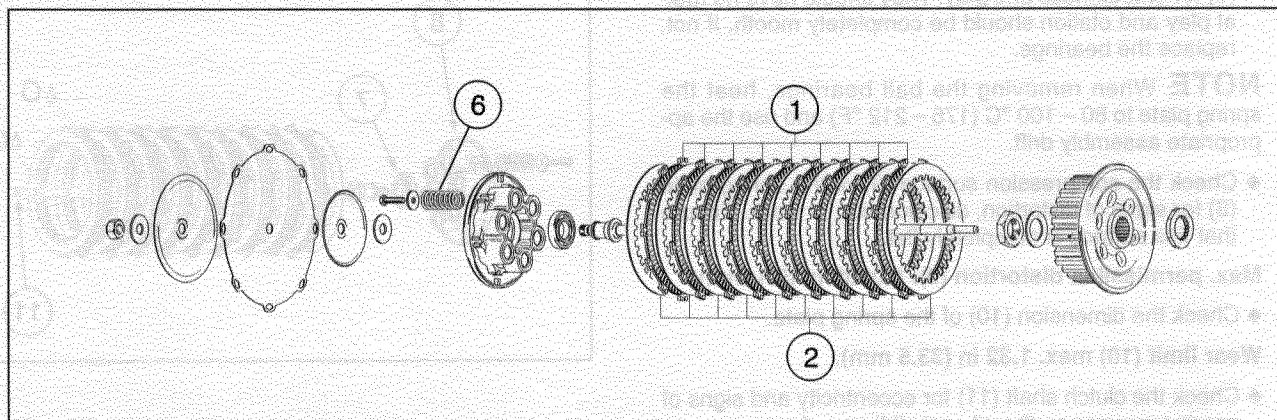

NOTE The following information may refer and should be observed with regard to all clutch versions.

For information refer to the clutch versions, see 5.16 [CLUTCH (VERSIONS)].

Carefully read 5.1 (PREFACE).

- ◆ Check the lined discs (1) and steel discs (2) for cracks or any distortion (3) by placing them on a flat surface.

Max. permissible distortion (3): 0.006 in (0.15 mm).

NOTE Reject any disc that is discolored or shows deep scratches or grooves.

- ◆ Measure the width (4) of the tab.

Wear limit (4) min. 0.54 in (13.7 mm).

NOTE Check the wear of the clutch discs, measuring the entire set of clutch discs (5).

Do not measure the steel disc set and the lined disc set separately, since separate measurements are not acceptable when checking the wear.

- ◆ Measure (5) the entire set of clutch discs (comprising ten steel discs and nine lined discs).

Wear limit (5) min. 1.77 in (44.9 mm).

NOTE The wear of one or more clutch discs (steel or lined discs) requires the renewal of the entire set of clutch discs (comprising ten steel discs and nine lined discs).

No partial renewal (of the worn discs only) is allowed.

NOTE The renewal of the entire set of clutch discs requires the renewal of all the clutch springs. It is not possible to install a new set of clutch discs with an old set of clutch springs.

- ◆ Measure the length of each clutch spring (6) in the free position.

Wear limit (6) min. 1.69 in (43.0 mm).

NOTE The wear of one or more clutch springs requires the renewal of all the clutch springs. No partial renewal (of the worn springs only) is allowed.

Follow ►

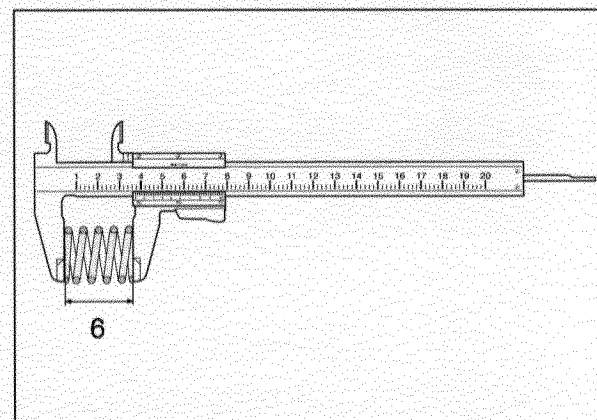
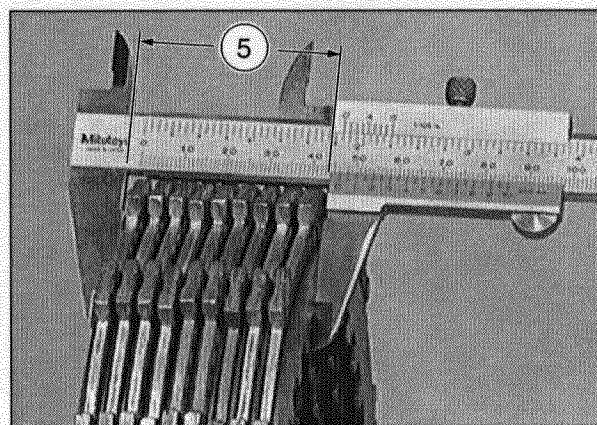
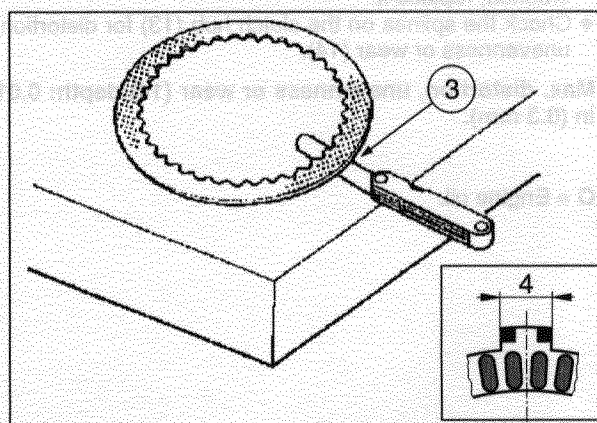

Follow ►

- ◆ Check the ball bearings (7) on the support-spring cups (8) for smoothness and play. They should have no radial play and rotation should be completely smooth. If not, replace the bearings.

NOTE When removing the ball bearings, heat the spring plate to 80 – 100 °C (176 – 212 °F) and use the appropriate assembly drift.

- ◆ Check the compression surface (9) of the spring plate (8) for signs of distortion, discoloration or wear. Ensure that this surface is completely flat.

Max. permissible distortion (9): 0.0039 in (0.1 mm).

- ◆ Check the dimension (10) of the spring plate.

Wear limit (10) max. 1.32 in (33.5 mm).

- ◆ Check the clutch shaft (11) for eccentricity and signs of scoring or wear on the oil seal sliding surface.
- ◆ Check the diaphragm (12) for cracks and. If it is cracked, replace it.
- ◆ Check the splines on the clutch hub (13) for distortion, unevenness or wear (14).

Max. distortion, unevenness or wear (14) depth: 0.01 in (0.3 mm).

○ = Engine oil.

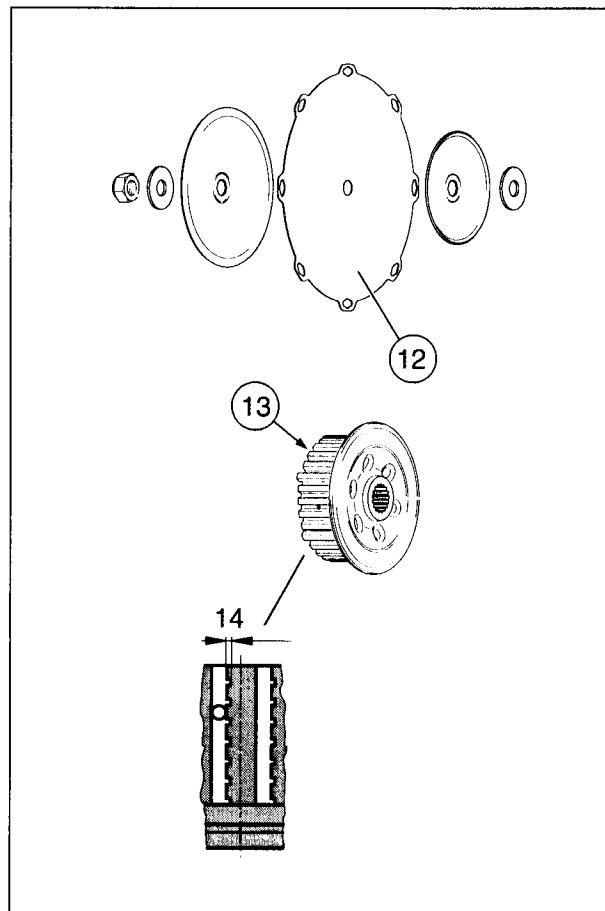
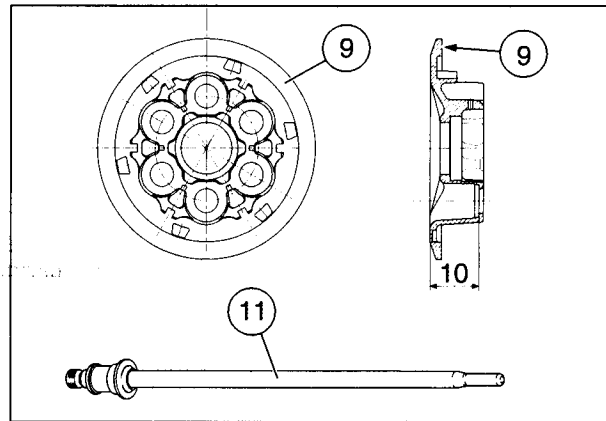
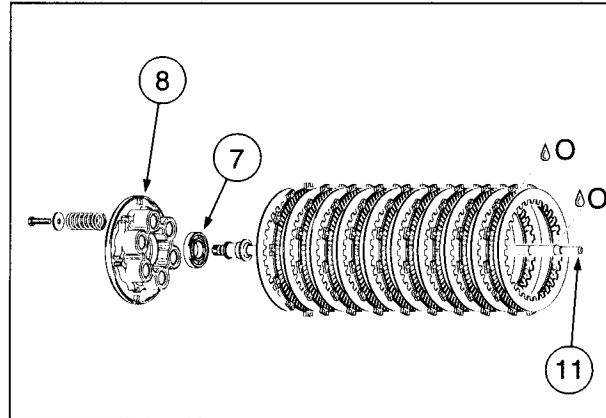

5.18 PRIMARY DRIVE (VERSIONS)

NOTE There are different primary transmission versions.

Consult the paragraph corresponding to the vehicle model on which the engine is installed.

Vehicle	Model	Primary transmission	Paragraph
RSV	'98 – '99	aprilia part# 0295790	5.19.1 (PRIMARY DRIVE aprilia part# 0295790)
	SP '99		
	2000		
	2001 USA		
RSV R	2000		
	2001 USA		
SL	2000 - 2001		
RST	2001 (engines up to aprilia part# 854075)		
RSV RSV R	2001 A AUS B CH D DK E F GR I J UK P	aprilia part# 0295792	5.19.2 (PRIMARY DRIVE aprilia part# 0295792 and 0295793)
	RST		
RST	2001 (engines aprilia part# 854076 and later)		
ETV	2001		
RSV RSV R SL RST ETV	2001 (engines aprilia part# 954102 and later)	0295793	5.19.2 (PRIMARY DRIVE aprilia part# 0295792 and 0295793)

NOTE Engines up to **aprilia** part# 954102 the primary drive is coded as follows: **aprilia** part# 0295792.
Engines **aprilia** part# 954103 and later the primary drive is coded as follows: **aprilia** part# 0295793.

Difference between the two codes: the primary drive **aprilia** part# 0295793 is provided with an additional shim (**aprilia** part# 0627910).

Code **aprilia** part# 0295793 cancels and replaces code **aprilia** part# 0295792.

It is possible to install the additional shim (**aprilia** part# 0627910) on the primary transmission **aprilia** part# 0295792 (thus transforming it into code **aprilia** part# 0295793).

In case this replacement is performed, only the primary transmission code **aprilia** part# 0295793 will be available as spare part.

NOTE

THIS PAGE HAS BEEN INTENTIONALLY LEFT EMPTY

5.19 DISASSEMBLING THE PRIMARY DRIVE

NOTE For information refer to the primary drive versions, see 5.18 [PRIMARY DRIVE (VERSIONS)].

5.19.1 PRIMARY DRIVE aprilia part# 0295790

Carefully read 5.1 (PREFACE).

DISASSEMBLY

- ◆ Remove the clutch, see 4.12 (DISASSEMBLING THE CLUTCH).
- ◆ Remove the primary drive assembly from the main shaft.
- ◆ Remove the washer (A) from the main shaft.
- ◆ Slip off the oil pump drive gear (1).
- ◆ Unscrew and remove the three M8 screws (2) and remove the spring-support plate (3).
- ◆ Remove the six compression rings (5) together with the twelve spring pins (6) from the clutch gear (4).
- ◆ Remove the clutch gear (4) with the spring washer (7) and the washer (8) from the clutch housing (9).

INSPECTION

- ◆ Check the wear of primary drive components, see 5.19.3 (PRIMARY DRIVE WEAR LIMITS).

PREASSEMBLY

- ◆ Insert the washer (8) and the spring washer (7) into clutch housing (9).

CAUTION

Install the spring washer with the concave face next to the clutch gear (4).

- ◆ Place the clutch gear (4) on the clutch housing and insert the six compression springs (5) along with the two spring pins (6) for each spring into their appropriate recesses in the clutch gear.

CAUTION

Use **LOCTITE® 648** on the three M8x16 Allen screws (2) of the spring-support plate (3).

NOTE Apply a couple of drops of **LOCTITE® 648** to the threads of the M8 screws (2).

- ◆ Install a spring-support plate (3) to the clutch gear (4) and fasten it with the three M8x16 screws (2).

Spring-support plate screws (2) tightening torque: 21.7 ftlb (30 Nm).

CAUTION

Once disassembled, always replace the oil pump drive gear (1).

- ◆ Place a new oil pump drive gear (1) so that its pins are engaged in the tabs (10) of the spring-support plate (3).
- ◆ Install the washer (A) on the main shaft.

NOTE To install the primary drive assembly on the main shaft, see 6.12 (ASSEMBLING THE PRIMARY DRIVE AND CLUTCH).

C = **LOCTITE® 648**.

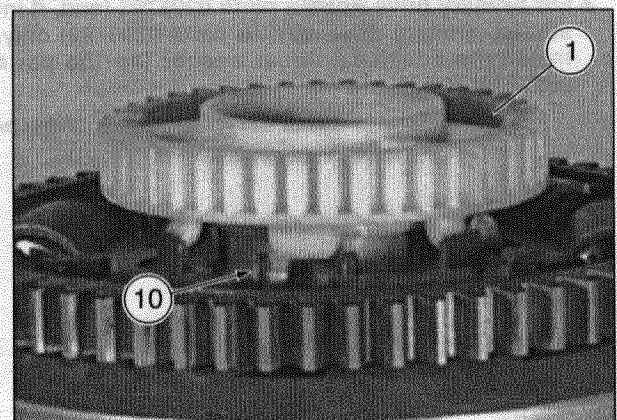
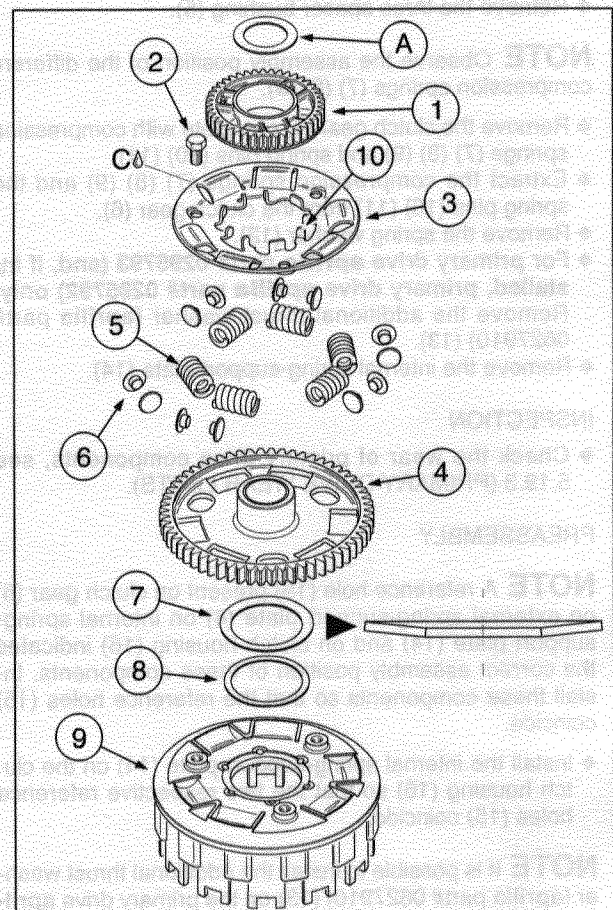
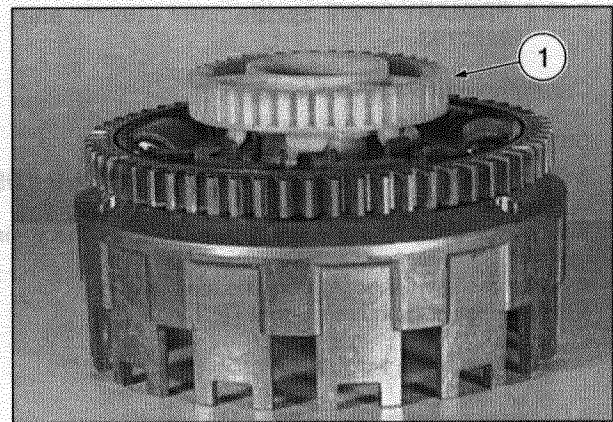

5.19.2 PRIMARY DRIVE **aprilia** part# 0295792 and 0295793

Carefully read 5.1 (PREFACE).

DISASSEMBLY

- ◆ Remove the clutch, see 4.12 (DISASSEMBLING THE CLUTCH).
- ◆ Remove the primary drive assembly from the main shaft.
- ◆ Remove the washer (A) from the main shaft.
- ◆ Slip off the oil pump drive gear (1).

Nut (2) tightening torque: 21.7 ftlb (30 Nm).

- ◆ Unscrew and remove the three M8 nuts (2).
- ◆ Retrieve the three M8 screws (3).
- ◆ Remove the external spring-support plate (4).
- ◆ Retrieve the three spacer bushing (5).

NOTE Observe the assembly position of the different compression springs (7) (8) (9).

- ◆ Remove the clutch gear (6) complete with compression springs (7) (8) (9) and spring pins (10) (11).
- ◆ Extract the compression springs (7) (8) (9) and the spring pins (10) (11) from the clutch gear (6).
- ◆ Remove the spring washer (12).
- ◆ **For primary drive **aprilia** part# 0295793 (and, if installed, primary drive **aprilia** part# 0295792) only.** Remove the additional thrust washer (**aprilia** part# 0627910) (13).
- ◆ Remove the internal spring-support plate (14).

INSPECTION

- ◆ Check the wear of primary drive components, see 5.19.3 (PRIMARY DRIVE WEAR LIMITS).

PREASSEMBLY

NOTE A reference hole (15) present on clutch gear (6) on external spring-support plate (4) on internal spring-support plate (14) and on clutch housing (16) indicates the correct assembly position of these components. Install these components so that the reference holes (15) coincide.

- ◆ Install the internal spring-support plate (14) on the clutch housing (16) so that the two respective reference holes (15) coincide.

NOTE It is possible to install the additional thrust washer (**aprilia** part# 0627910) (13) on the primary drive **aprilia** part# 0295792 (thus transforming it into code **aprilia** part# 0295793).

- ◆ **For primary drive **aprilia** part# 0295793 (and, if installed, primary drive **aprilia** part# 0295792) only.** Install the additional thrust washer (**aprilia** part# 0627910) (13).

Follow ▶

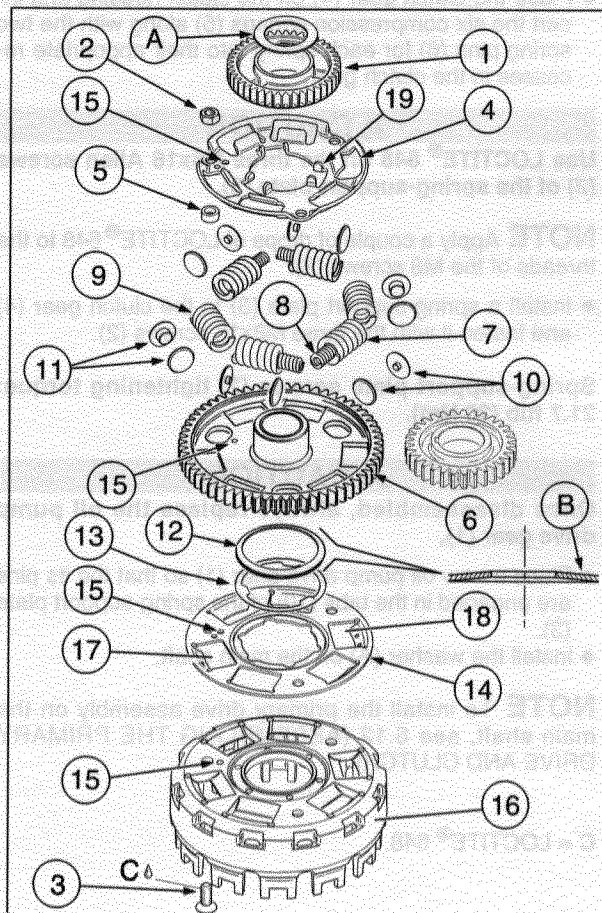
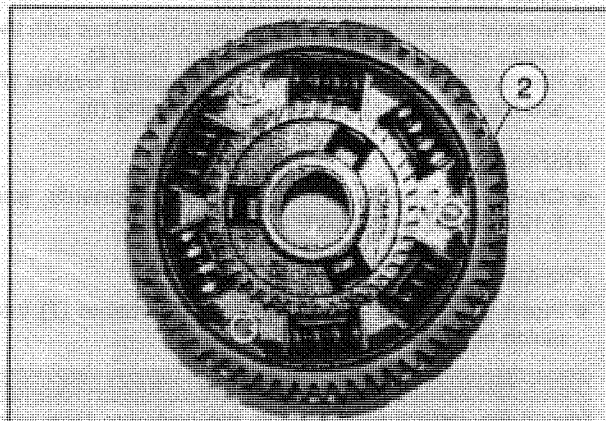
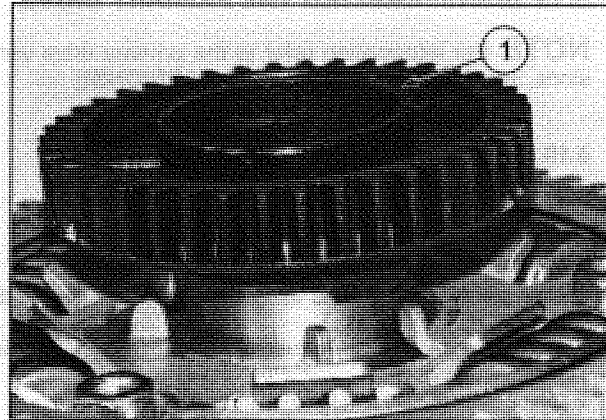

Follow ▶

- ◆ Install the spring washer (12) with external diameter (B) towards the internal spring-support plate (14).
- ◆ Install the clutch gear (6) so that its reference hole (15) coincide with the reference holes (15) of the internal spring-support plate (14).
- ◆ Insert the two compression springs (9), marked with color white, along with the corresponding two spring pins (11) for each spring, into their appropriate recesses:
 - (17) (marked with one hole);
 - (18) (marked with two holes);

in the internal spring-support plate (14).

- ◆ Insert the four internal compression springs (8) in the four external compression springs (7) and insert in each compression spring group the two spring pins (10).
- ◆ Install the four compression spring groups (7) (8) (10) in the appropriate recesses.
- ◆ Install the three spacer bushing (5).
- ◆ Install the external spring-support plate (4).

CAUTION

Use **LOCTITE® 648** on the three M8x25 Allen screws (17) of the external spring-support plate (4).

NOTE Apply a couple of drops of **LOCTITE® 648** to the threads of the M8x25 screws (3).

- ◆ Working from the clutch housing (16) side, install the three of the M8x25 screws (3).
- ◆ Screw in and tighten the three M8 nuts (2).

External spring-support plate nut (2) tightening torque: 21.7 ftlb (30 Nm).

CAUTION

Once disassembled, always replace the oil pump drive gear (1).

- ◆ Place a new oil pump drive gear (1) so that its pins are engaged in the tabs (19) of the external spring-support plate (4).
- ◆ Install the washer (A) on the main shaft.

NOTE To install the primary drive assembly on the main shaft, see 6.12 (ASSEMBLING THE PRIMARY DRIVE AND CLUTCH).

C = LOCTITE® 648

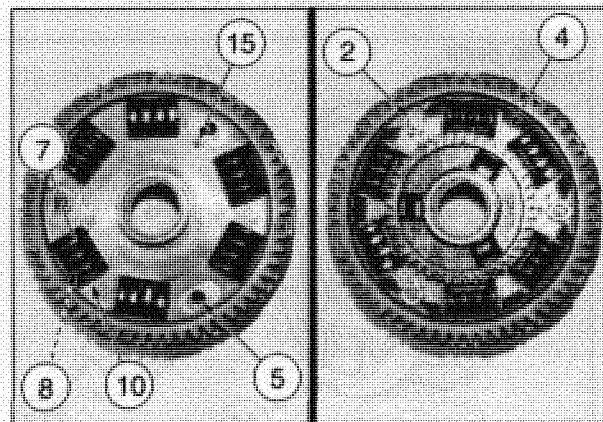
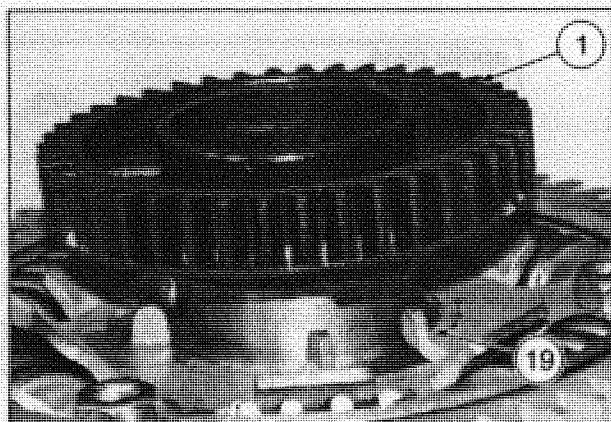
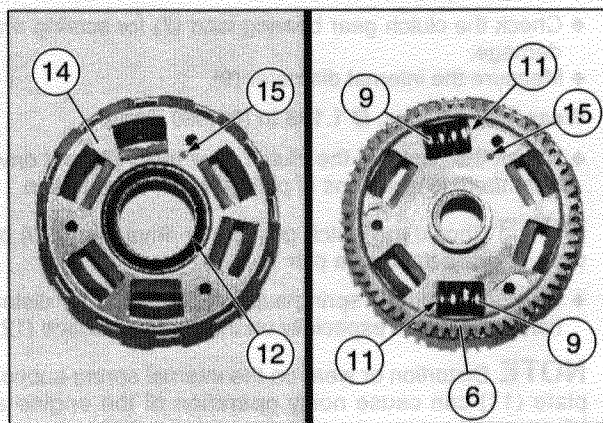
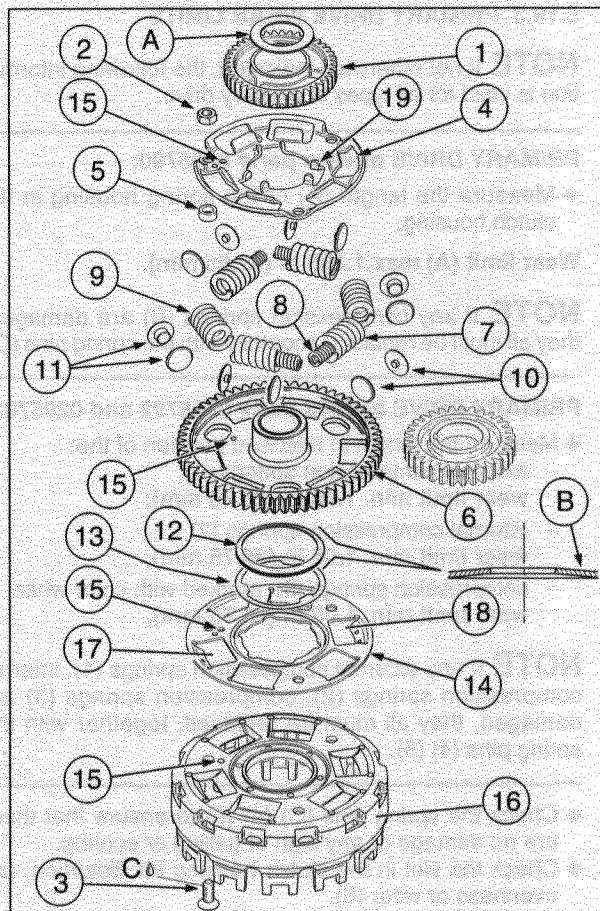

5.19.3 PRIMARY DRIVE WEAR LIMITS

NOTE If not otherwise indicated, the following information is valid for all types of primary drive.

PRIMARY DRIVE aprilia part# 0295790:

◆ Measure the length (A) of the spring housing in the clutch housing.

Wear limit (A) max. 1.285 in (32.65 mm).

NOTE If any compression springs (B) are damaged, they all must be replaced, together with the spring pins (C).

PRIMARY DRIVE aprilia part# 0295792 and 0295793:

- ◆ Measure the length in released position of the:
 - external compression springs (1),
wear limit min. 1.05 in (26.75 mm);
 - internal compression springs (2),
wear limit min. 1.05 in (26.75 mm);
 - compression springs (3), marked with color white,
wear limit min. 1.05 in (26.75 mm),

NOTE If any external compression springs (1), internal compression springs (2), compression springs (3) are damaged, they all must be replaced, together with the spring pins (4) (5).

- ◆ Check the spring pins (C) (4) (5) to ensure that there are no damage or any sign of galling or scoring.
- ◆ Check the slot in the clutch housing for distortion, unevenness or wear (6).

Max. distortion, unevenness or wear (6) depth: 0.01 in (0.3 mm).

- ◆ Check the clutch gear bearing land (7) for scoring and damage.
- ◆ Measure the internal diameter (9).

Wear limit (9) max. Ø 1.183 in (30.060 mm).

◆ Check the flanks of the clutch gear teeth (8) and drive gear teeth (9) for signs of pitting, wear, or distortion.

NOTE Should the clutch gear (8) or drive gear (10) be worn, replace them as a pair.

◆ Check the internal spring-support plate (11) for distortion or wear with especially on the contact surface (12).

NOTE Distortion or wear on the internal spring-support plate (11) can cause noisy operation of the engine at idling speed.

◆ Check the internal spring-support plate (11) and the external spring-support plate (11) for cracks.

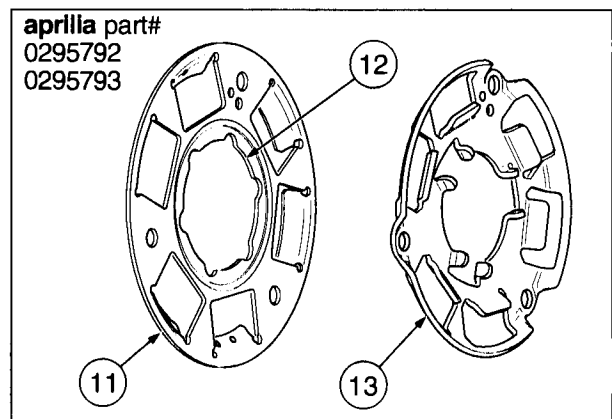
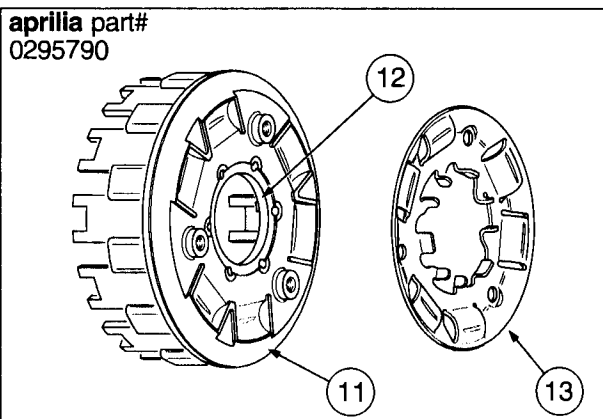
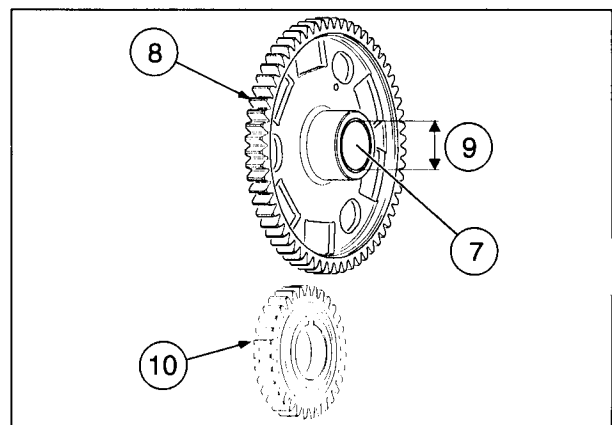
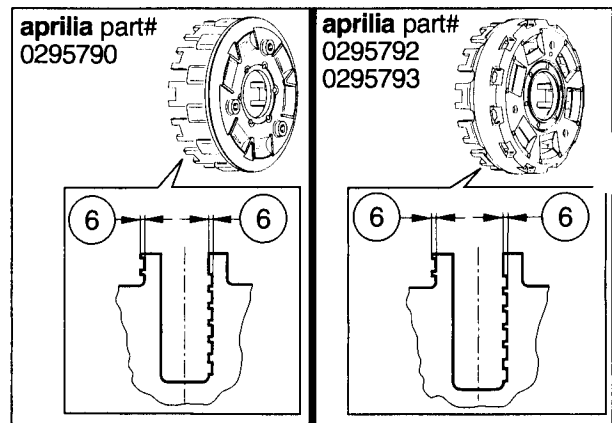
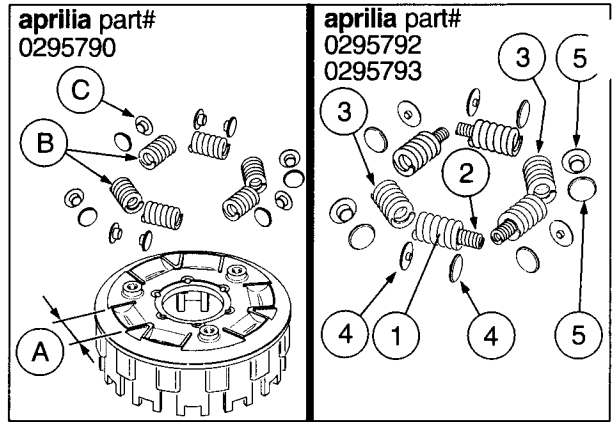

NOTE

Lined area for notes, currently empty.

THIS PAGE HAS BEEN INTENTIONALLY LEFT EMPTY

5.20 CLUTCH COVER

Carefully read 5.1 (PREFACE).

- ◆ Check the gasket surface for signs of damage and check the complete thread to ensure it is in a perfect state of repair.
- ◆ Check the crankshaft support bearings (1) and bal-
anceshaft support bearings (2) for signs of galling or
scoring.
- ◆ Measure the diameter of the two support bearings.
 - Crankshaft support bearings:
wear limit \varnothing 1.1827 in (30.040 mm).
 - Balanceshaft support bearings:
wear limit \varnothing 0.7898 in (20.060 mm).

CAUTION

Take a number of measurements, especially in the di-
rection of the axis of both cylinders.
None of the values must exceed the limit value.

- ◆ Measure the radial play of the crankshaft and lower bal-
anceshaft, see 5.4 (CRANKSHAFT MAIN BUSHINGS
AND LOWER BALANCESHAFT MAIN BUSHINGS).

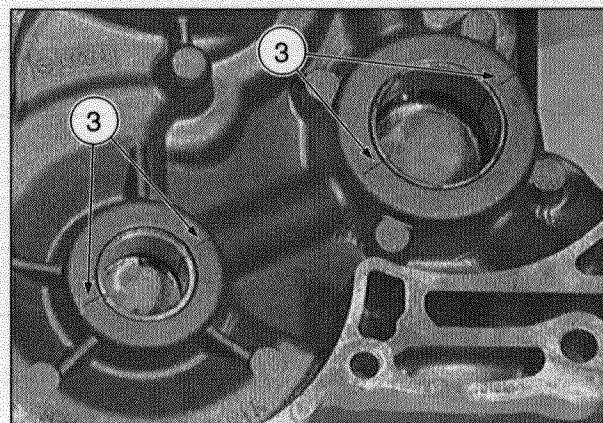
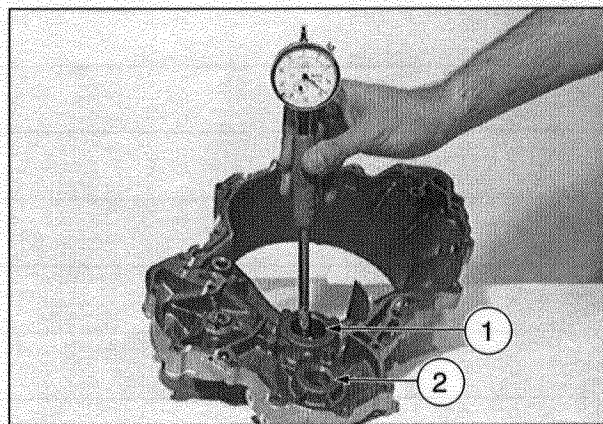

5.21 SUPPORT BEARINGS

Carefully read 5.1 (PREFACE).

5.21.1 DISASSEMBLY

- ◆ Mark the contact surface (3) of the two bearings on the
clutch cover.

NOTE Have the appropriate special tool **OPT** available:
– **aprilia** part# 8140156 + 8140157 + 0276377 (clutch
cover sleeve puller) (4).

- ◆ Remove the main bearings with the special tool (4).

CAUTION

As a rule, the main bearings should all be replaced
together.

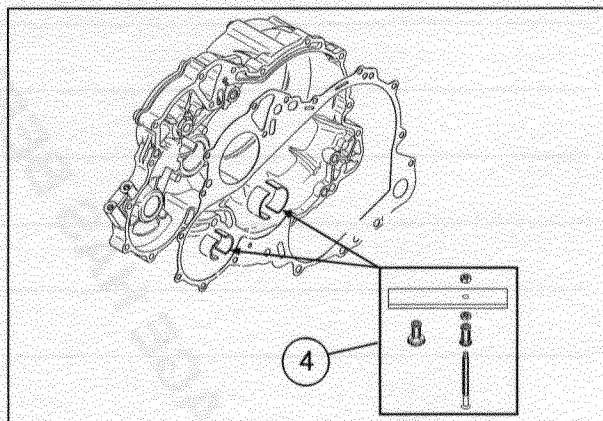

5.21.2 ASSEMBLY

- ◆ Clean the diameter of the main bearing housing and the lubrication hole between the bearing housings inside the clutch cover.
- ◆ Determine the crankshaft bearings size group based on the colored markings (5) on the clutch cover.

NOTE The size group of the main bearings is also marked with a colored dot.

- ◆ If the colored marking on the clutch cover is no longer clearly visible, calculate the diameter based on the average of a number of separate measurements.

CAUTION

Take a number of measurements, especially in the direction of the axis of both cylinders.

Hole in the clutch cover	Bearing cover marking	Clutch cover marking
Ø 1.2961 – 1.2965 in (32.921 – 32.930 mm)	red	red
Ø 1.2965 – 1.2968 in (32.930 – 32.940 mm)	blue	blue
Ø 1.2986 – 1.2973 in (32.940 – 32.951 mm)	yellow	yellow

- ◆ Heat the engine case to approximately 130 °C (266 °F).
- ◆ Coat the main bearings and the bearing housings in the clutch cover with MOLYKOTE® G-N.

NOTE Have the appropriate special tool **OPT** available:

- aprilia part# 0277727 (crankshaft-clutch cover bushing inserter drift) (6);
- aprilia part# 0277729 (lower balancershaft bushing inserter drift) (7).

- ◆ Place the crankshaft and balancershaft main bearings on the assembly drift (6) (7), using the suitable O-ring (8) to hold them in place.
- ◆ Line up your marks on the main bearings and the case (3).
- ◆ Using great care, insert the main bearings into the case. Using the appropriate assembly drift and a press, press the bearings in until the assembly drift just touches the case.

CAUTION

While inserting or removing the main bushings, the engine case must be supported through 360°, in the area of the bushing bore. The best way to accomplish this is to use a cylindrical support surface, which supports the case in the vicinity of the bushing bore, and hold the case absolutely perpendicular to the press used to remove or install the bushings.

- ◆ Remove the O-ring (8) before the installer drift makes contact.
 - The crankshaft main bearings must be flush with the thrust surface (9).
 - The balancershaft bearings must be pressed 0.039 in (1.0 mm) below the thrust surface (10).

CAUTION

Once disassembled, the bearings must not be re-used.

M = MOLYKOTE® G-N.

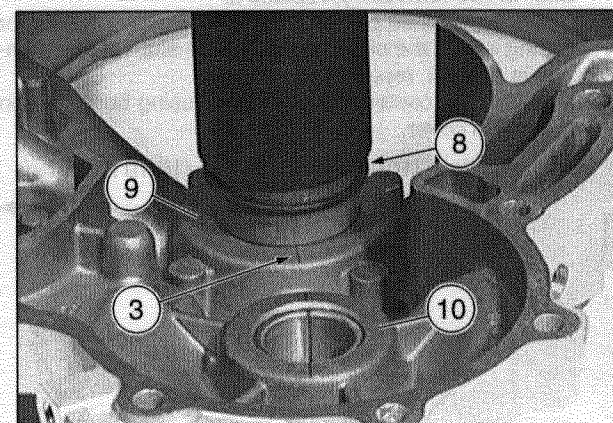
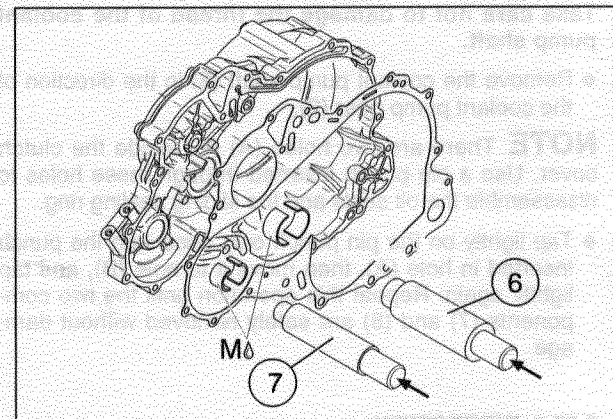
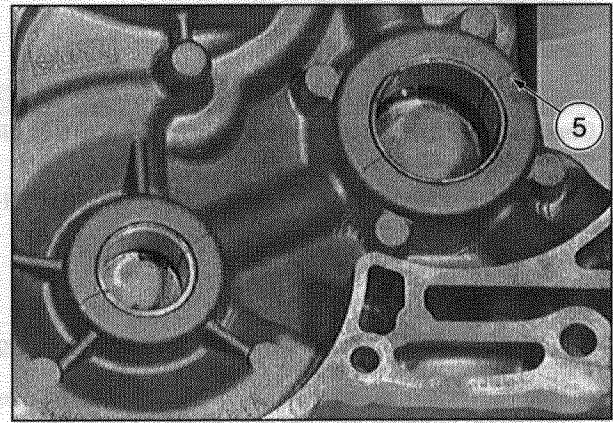

5.22 COOLANT PUMP

Carefully read 5.1 (PREFACE).

CAUTION

Disassemble the coolant pump only in the event of oil or coolant leakage.

- ◆ Check the drainage hole (1) for any signs of oil or coolant leakage.

5.22.1 DISASSEMBLY

- ◆ Prevent the coolant pump gear from rotating by holding it with a rag while unscrewing the impeller (3).
- ◆ Slide the coolant pump gear (2) up and off, and remove the pin (4) together with the washer (5).

CAUTION

Take care not to damage the thread of the coolant pump shaft.

- ◆ Remove the coolant pump shaft (6) in the direction of the coolant pump gear (2).

NOTE There are two holes (A) (B) inside the clutch cover. Use a pin punch inserted through these holes to disassemble the oil seals and the sliding sealing ring.

- ◆ Tap lightly on the pin punch only once with the punch inserted in hole (A), then move it to hole (B), and tap lightly again. Repeat this operation until the two components (7) and (8) are safely removed without damage.

5.22.2 INSPECTION

- ◆ Check the impeller (3) for signs of damage or distortion and, where necessary, replace it.
- ◆ Check the coolant pump shaft (6) for signs of scoring or galling where the oil seal rides on the shaft. If any damage is evident, replace the shaft.
- ◆ Measure the coolant pump shaft housing bore (10) on the clutch cover.

Bore wear limit (10) max. Ø 0.397 in (10.10 mm).

Follow ►

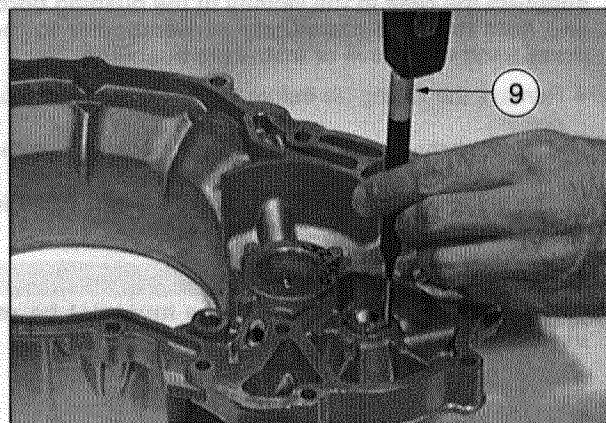
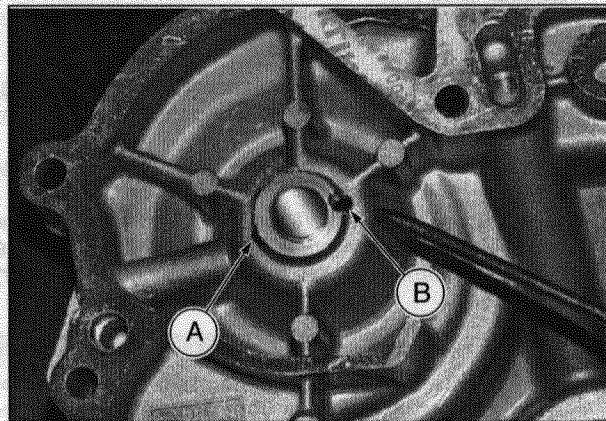
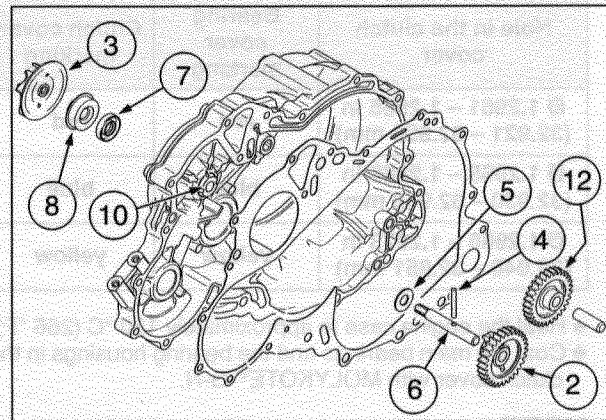
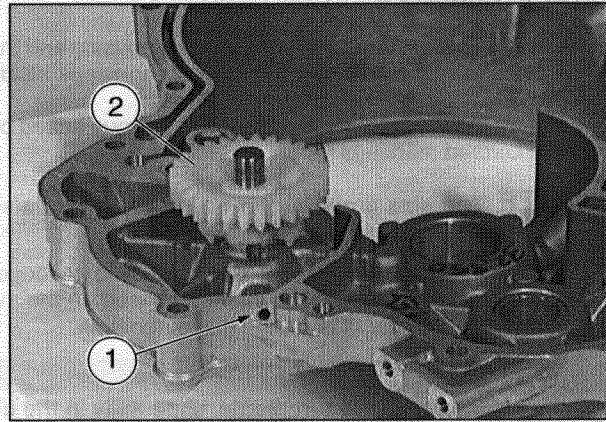

Follow ►

- ◆ Check the teeth of the coolant pump gear (2) for signs of damage or scoring. Check the width of the drive pin groove (11).

Groove wear limit (11) max. \varnothing 0.146 in (3.70 mm).

- ◆ Check the teeth of the coolant pump idler gear (12) for damage or pitting.
- ◆ Measure the gear bore (13).

Gear bore wear limit (13) max. \varnothing 0.402 in (10.22 mm).

5.22.3 ASSEMBLY

NOTE Have the appropriate special tool **OPT** available:

- aprilia part# 0877650 (handle for drift) (14);
- aprilia part# 0277670 (coolant pump shaft housing oil seal assembly drift) (15);
- aprilia part# 0877257 (coolant pump shaft housing sliding ring assembly drift) (16).

NOTE The closed side of the oil seal must be fitted so that it faces the impeller (3).

- ◆ Install the oil seal (7) completely into its recess using the drift.
- ◆ Install the sliding sealing ring (8) into the recess as far as it will go using the assembly drift.

CAUTION

Take care not to damage the impeller (3).

- ◆ Screw in the impeller (3), by hand, until it bottoms onto the coolant pump shaft (6).
- ◆ Coat the coolant pump shaft (6) with MOLYKOTE® G-N and insert it from the outside all the way onto the oil seal assembly.
- ◆ Install the washer (5) on the coolant pump shaft.
- ◆ Install the pin (4) in its hole in the coolant pump shaft and then install the coolant pump gear (2) on the shaft.

NOTE Ensure that the pin is perfectly aligned with its mating groove in the cooling pump gear.

- ◆ Tighten the impeller (3) by hand, while you hold the coolant pump gear (2) with a rag.

M = MOLYKOTE® G-N.

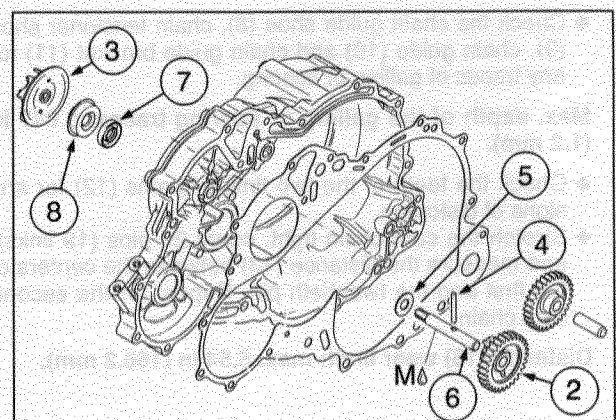
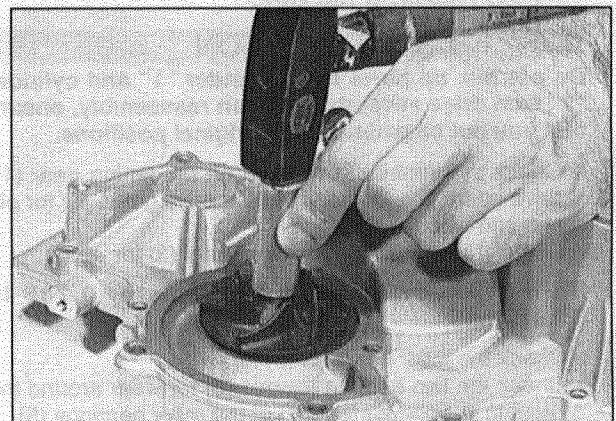
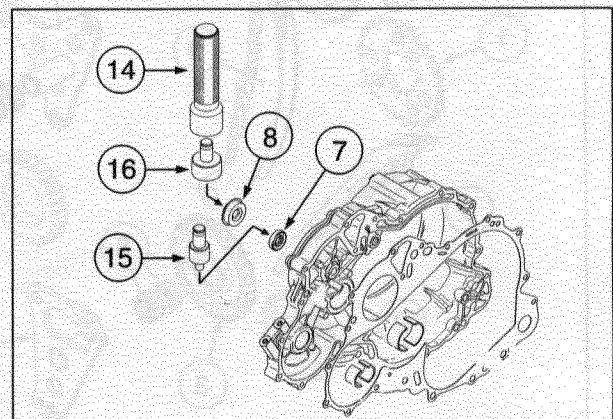
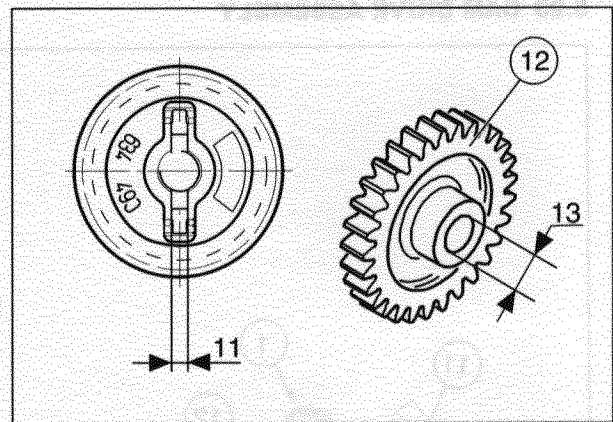

5.23 CAM DRIVE ASSEMBLY

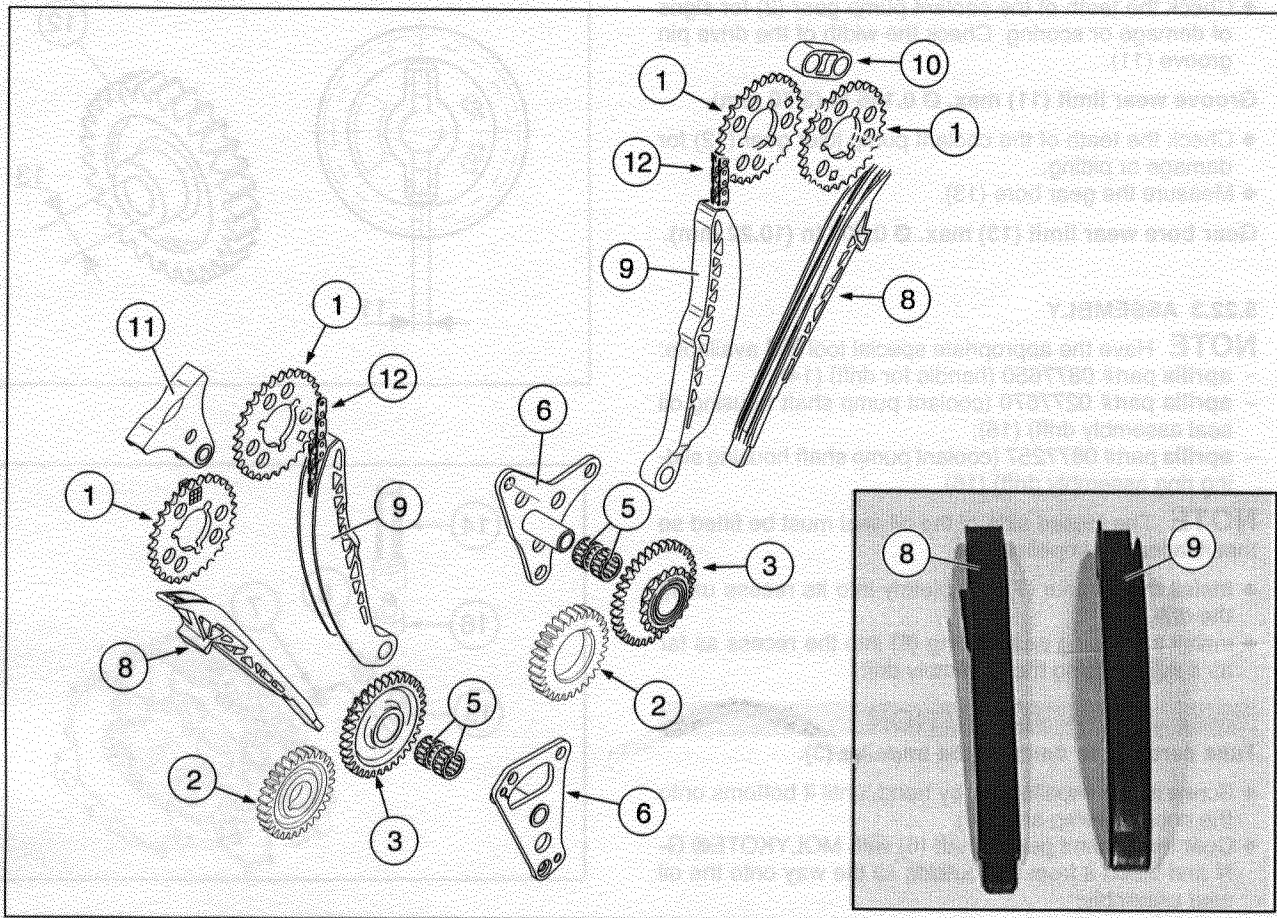

Carefully read 5.1 (PREFACE).

CAUTION

Do not mix up parts from cylinder "1" and cylinder "2" cam drive assemblies. Upon reassembly, ensure that you put all parts in their original positions.

- ◆ Check the flanks of the teeth on the timing gear (1), drive gears (2) and intermediate drive gears (3) for pitting and wear.
- ◆ Check the bore (4) of the idler gears (3) for wear.

Bore (4) wear limit: max. diameter 0.788 in (20.015 mm).

- ◆ Check the roller bearings (5) for wear.
- ◆ Check the two bearing flanges (6) for wear around the bearing support surface (7) of the roller bearings (5).

Bearing support surface (7) wear limit: min. diameter 0.629 in (15.98 mm).

- ◆ Check the chain guide shoe (8), chain tensioner shoe (9), chain guide (10) and chain guide bracket (11) for any traces of galling or scoring.

Max. depth of the galling or scoring traces: 0.047 in (1.2 mm).

- ◆ Check the teeth of the two timing chains (12) for any signs of distortion.
- ◆ Stretch the cam chain tight, count 20 pins (19 links), and measure the distance (13) between the centers of the first and the twentieth pin. Repeat for the second cam chain.

Distance (13) wear limit: max. 6.54 in (166.2 mm).

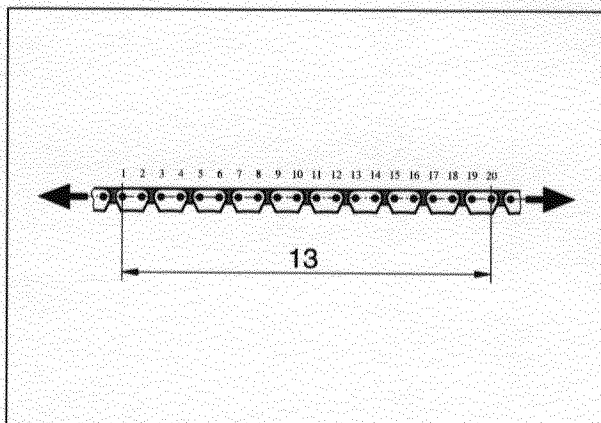
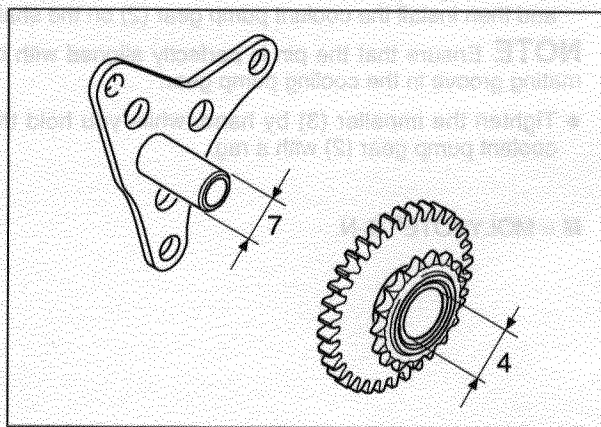

5.24 HEAD AND CAMSHAFT

Carefully read 5.1 (PREFACE).

5.24.1 ASSEMBLY

- ◆ Unscrew and remove the four shouldered M8 screws (1) respectively and remove head "1" and "2" from the cylinder.
- ◆ Unscrew and remove the four M6 Allen screws (2) together with the respective washers (3) from head "2" and remove the chain guide (4) and the bushing plate (5).
- ◆ Remove the upper balanceshaft (6) from head "2".
- ◆ Unscrew and remove the eight M6 Allen screws (7), together with the respective washers (8), and remove the camshaft cap (9) from head "1" and "2".
- ◆ Remove the intake camshaft (10) and exhaust camshaft (11) from head "1" and "2".

CAUTION

Do not mix up components from cylinder "1" and cylinder "2". When you reassemble the cylinders, ensure that all parts fit in their original positions.

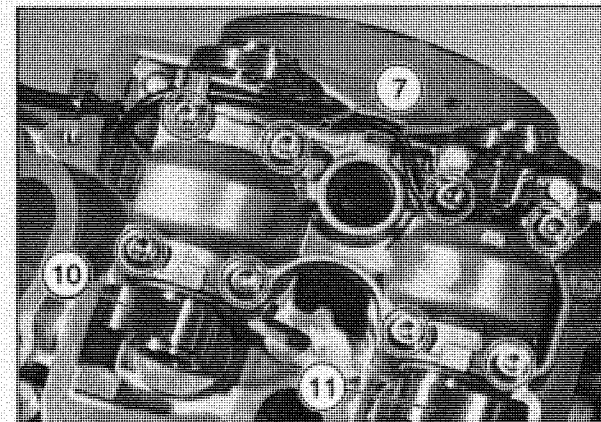
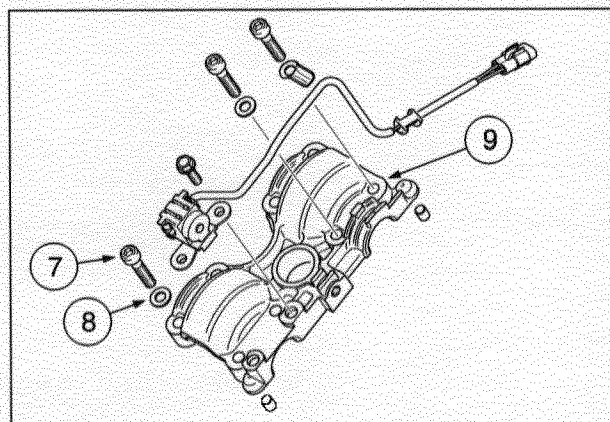
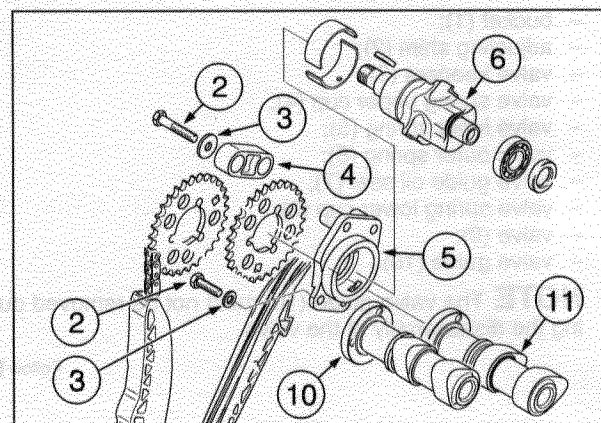
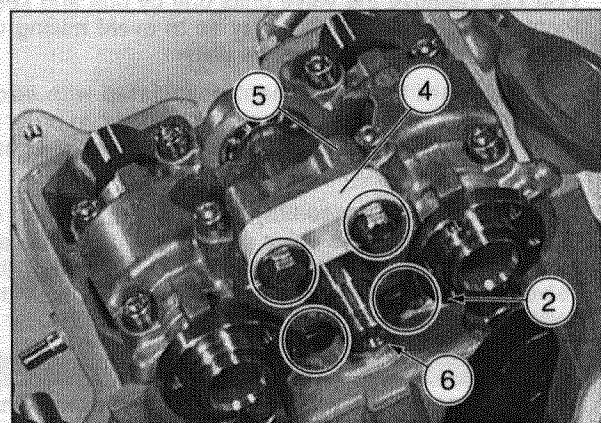
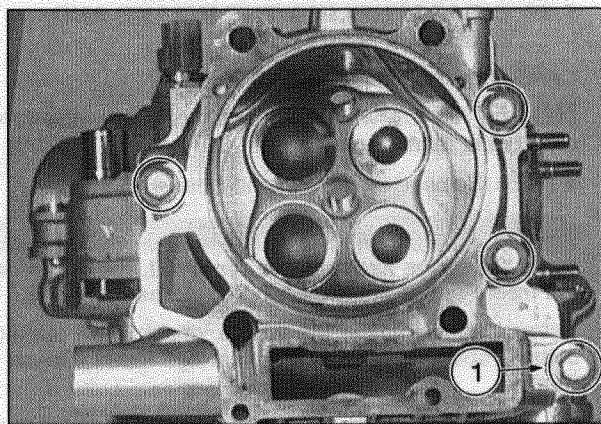

5.25 DISASSEMBLING THE INTAKE AND EXHAUST VALVES

Carefully read 5.1 (PREFACE).

NOTE The following information refers to one valve only, but is valid for all of them.

◆ Place the head on a clean and clear work bench.

CAUTION

Once the valve keepers are removed, the valve can fall freely out of the head, and could be damaged.

Before disassembling the valves, check valve leakage using a special cylinder head leakage tester (Bosch or Sun).

NOTE If the leakage is less than 5%, the valves and valve seat are in satisfactory condition.

NOTE Remove the valve units one by one and keep them separated, in such a way as to avoid mixing up components from different valve units.

NOTE Mark the component associated with each valve, and its corresponding seat in the head, in order to be able to reinstall the components in their original position.

NOTE Before disassembly, mark the upper end of each valve spring. The valve springs are progressively wound, so must be installed properly. The end of the valve with the more tightly wound coils must face the combustion chamber.

CAUTION

Do not assemble the valve springs upside down. This can cause irreparable engine damage.

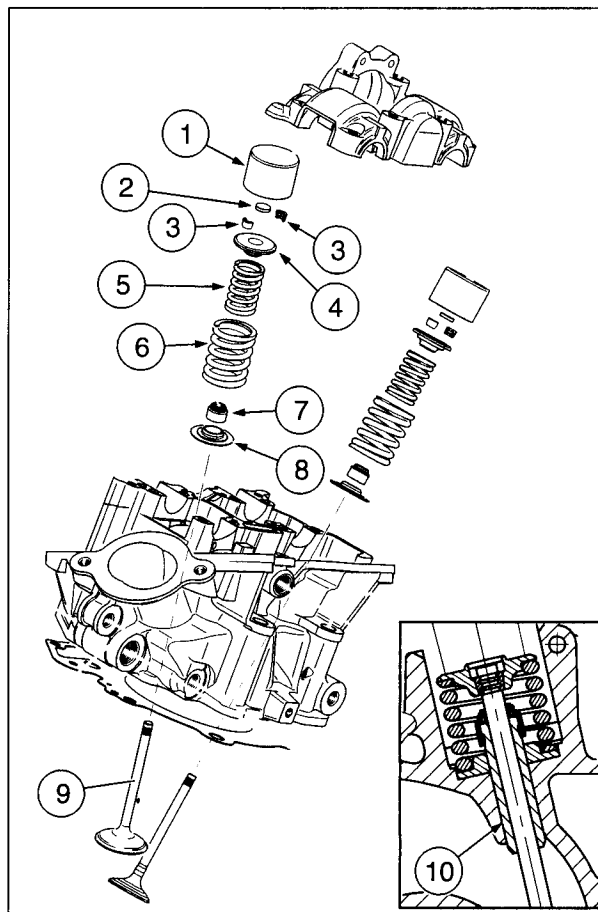

Valve unit components (intake or exhaust valve):

- bucket (1);
- adjusting shim (2);
- valve keepers (3);
- valve spring upper cup (4);
- valve inner spring (5);
- valve outer spring (6);
- valve guide oil seal (7);
- valve spring lower cup (8);
- valve (9);
- valve guide (10).

NOTE The valve guide (10) must not be removed during the disassembly of the valve.

Follow ►

Follow ▶

NOTE Have the appropriate special tool **OPT** available:

- **aprilia** part# 8140179 (valves disassembly and reassembly clamp) (11);
- **aprilia** part# 0276479 (valves spring-pusher tool) (12).

- ◆ Remove the valve lifter bucket (1) and the adjusting shim (2).
- ◆ Compress the valve springs (5) (6) using the clamp (11) and the valve spring compression tool (12), and remove the valve keepers (3).
- ◆ * Release the valve springs (5) (6).
- ◆ * Remove the spring compressor (12) and the clamp (11).
- ◆ * Remove the valve spring upper cup (4).
- ◆ * Withdraw the two valve springs (5) (6).
- ◆ * Raise and rotate the head by 180° (upside down).
- ◆ * Withdraw the valve (9).

NOTE Repeat the operations marked with "*" for the second valve.

- ◆ Clean the combustion chamber, removing the residual combustion products and the deposits from the cooling chamber.
- ◆ Check the thread of the spark plugs and the fastening thread, making sure they are in a perfect state of repair.
- ◆ Check that the oil galleries are unobstructed and blow them clean using compressed air.
- ◆ Check the gasket surfaces for any signs of damage and ensure that they are flat.

Max. permissible distortion: 0.001 in (0.03 mm).

CAUTION

If the limit value is exceeded, we strongly suggest that you contact:

aprilia USA inc.
 110 Londonderry Court, Suite 130
 Woodstock, GA 30188
 USA
 Tel 770 592 2261
 Fax 770 592 4878

- ◆ Inspect the valve buckets (1) and their mating bore in the head; they must be in perfect condition.
- Buckets mating bore in the head (13):
 wear limit: max. \varnothing 1.322 in (33.58 mm);
- Buckets (1) external diameter:
 wear limit: min. \varnothing 1.316 in (33.44 mm);
- Buckets radial play (1):
 wear limit: max. \varnothing 0.003 in (0.08 mm).

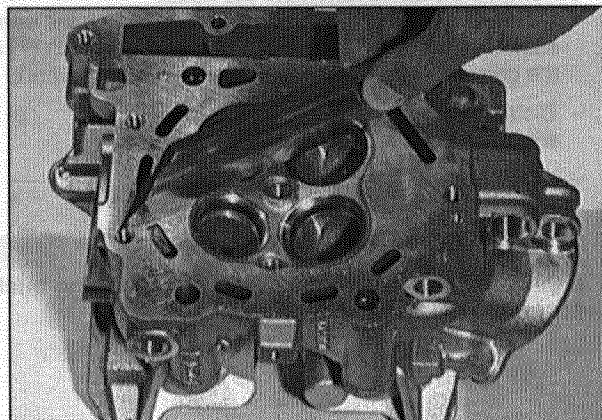
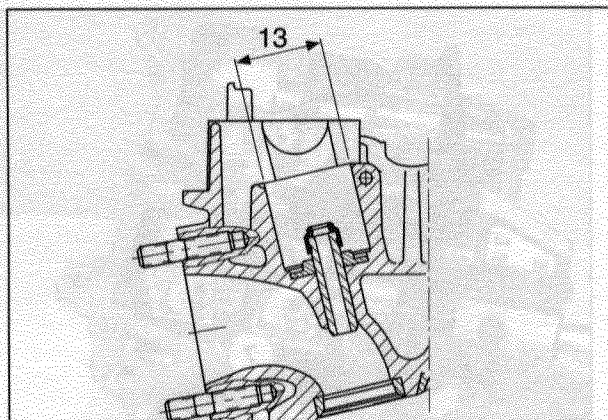
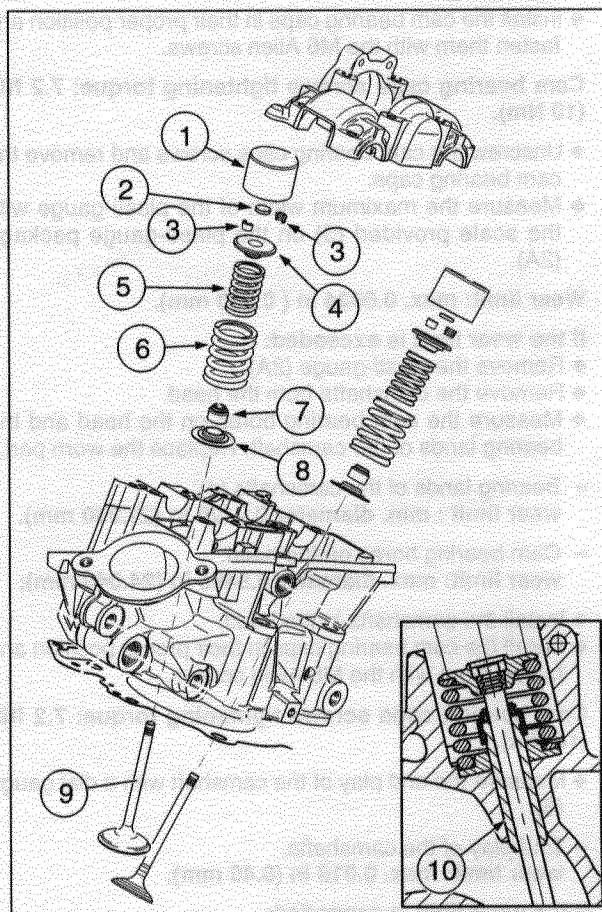
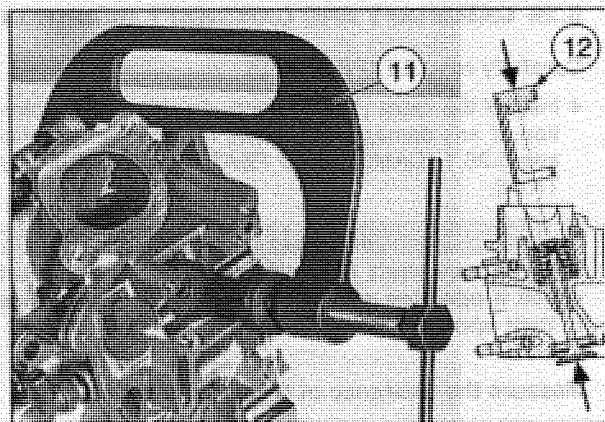

5.26 CAMSHAFT AND CAMSHAFT BEARINGS

Carefully read 5.1 (PREFACE).

- ◆ Inspect the cams (1) for galling, distortion or discoloration. If any damage is present, replace the camshaft, see 5.26.1 (CAMSHAFTS FEATURES CLASSIFICATION).

CAUTION

When a camshaft is replaced, the valve buckets which it operates must also be replaced, regardless of their apparent condition.

Measure the clearance of the camshafts bearings:

- ◆ Install the camshafts in the head.
- ◆ Apply a plasti-gauge (2) on the bearing lands of the camshafts.
- ◆ Install the cam bearing caps in their proper position and fasten them with the M6 Allen screws.

Cam bearing caps screws tightening torque: 7.2 ftlb (10 Nm).

- ◆ Unscrew the cam bearing caps screws and remove the cam bearing caps.
- ◆ Measure the maximum width of the plasti-gauge with the scale provided (3) on the plasti-gauge package (2A).

Wear limit: max. 0.0024 in (0.060 mm).

If the wear limit is exceeded:

- ◆ Remove the plasti-gauge (2A).
- ◆ Remove the camshafts from the head.
- ◆ Measure the cam bearing bores on the head and the bearing lands of the camshaft. Replace the worn part.

– Bearing lands of the camshafts (4):
wear limit : min. diameter 0.9429 in (23.950 mm).

– Cam bearing bores on the head:
wear limit: max. diameter 0.9465 in (24.040 mm);

- ◆ Install the camshafts in the head.
- ◆ Install the cam bearing caps in their proper position and fasten them with the M6 Allen screws.

Cam bearing caps screws tightening torque: 7.2 ftlb (10 Nm).

- ◆ Measure the end play of the camshaft with a dial gauge (5).

– End play of the camshafts,
wear limit: max. 0.016 in (0.40 mm).

If the wear limit is exceeded:

- ◆ Unscrew the cam bearing caps screws and remove the cam bearing caps.
- ◆ Remove the camshafts from the head.
- ◆ Measure the length (6) of the bearing land on the camshaft that contains the thrust faces and the width (7) of the cam bearing in the head. Replace the worn part.

– Distance between thrust contact surfaces:
wear limit: max. 1.093 in (27.77 mm).

– Width of cam bearing and head:
wear limit: min. 1.067 in (27.10 mm).

CAUTION

If the camshaft is replaced, the corresponding buckets must also be replaced.

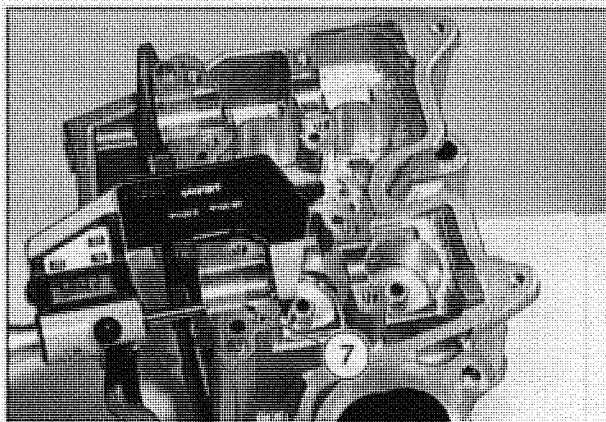
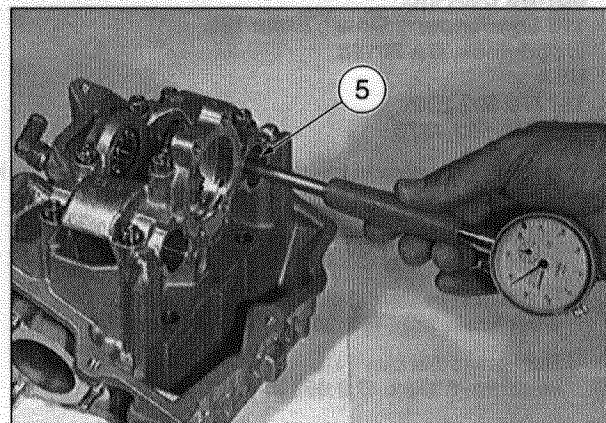
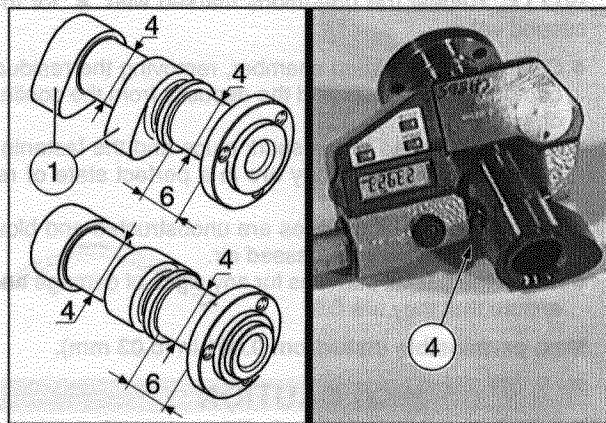
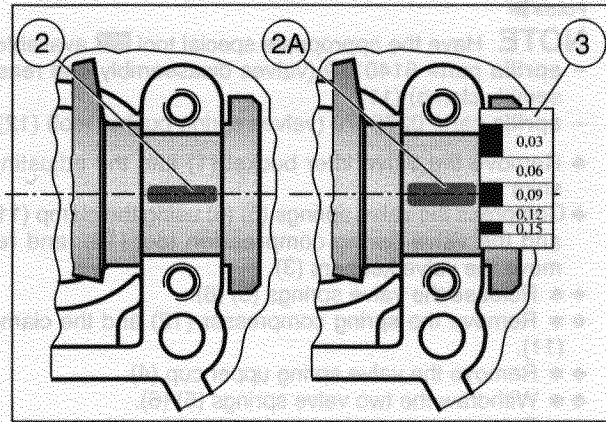

5.26.1 (CAMSHAFTS FEATURES CLASSIFICATION)

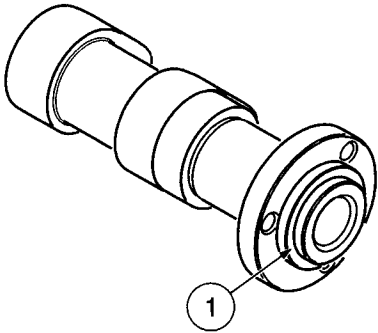
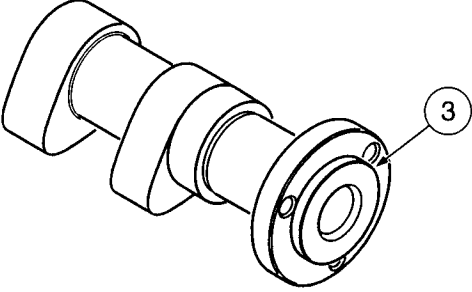
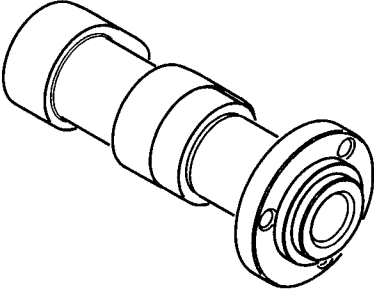
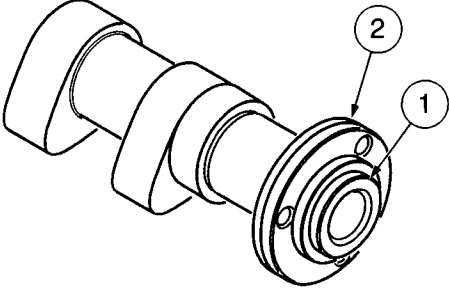
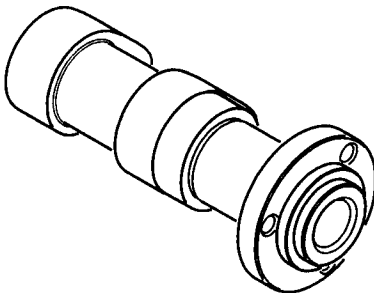
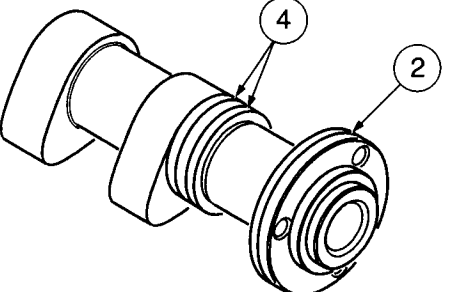
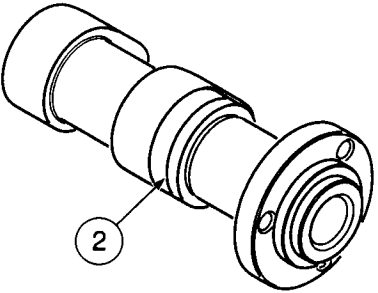
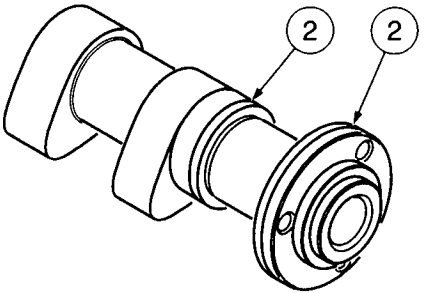
Vehicle model	Exhaust camshaft	Intake camshaft
<p>RSV RSV R (engines up to # 524388).</p>	<p>aprilia part# 0220385</p> 	<p>aprilia part# 0220380</p> 
<p>RSV RSV R (engines # 524389 and later);</p> <p>RSV RSV R (vehicles up to year 2000);</p> <p>SL ;</p> <p>RST .</p>	<p>aprilia part# 0220385</p> 	<p>aprilia part# 0220380</p> 
<p>RSV RSV R (vehicles year 2001 and later).</p>	<p>aprilia part# 0220385</p> 	<p>aprilia part# 0220384</p> 
<p>ETV .</p>	<p>aprilia part# 0220387</p> 	<p>aprilia part# 0220382</p> 

Key

- 1) Double shoulder
- 2) Recognition groove

- 3) Shoulder
- 4) Double recognition groove

5.27 UPPER BALANCSHAFT

Carefully read 5.1 (PREFACE).

- ◆ Check the balancershaft for wear.

NOTE The bearing land (1) is slightly tapered. The measurement must be taken half-way along its length.

- Bearing land (1):
wear limit: min. diameter 1.377 in (34.98 mm).
- Ball bearing land (2):
wear limit: min. diameter 0.589 in (14.97 mm).

NOTE The bearing land (3) is slightly tapered.

- ◆ Check the internal diameter (3) for cracking, wear, distortion or scoring.
- ◆ Install the balancershaft in the plate (3) and measure the radial play using a dial gauge.

Max. permissible radial play 0.028 in (0.70 mm).

⚠ CAUTION

If the maximum permissible radial play is exceeded, the worn part must be replaced.

⚠ CAUTION

Should the bearing surface in the plate (3) be worn, the complete plate (6) must be replaced.

- ◆ Install the balancershaft in the head "2" (rear) and measure the end play with a dial gauge.

Wear limit: max. 0.0016 in (0.040 mm).

⚠ CAUTION

If the end play wear limit is exceeded, replace the plate (6).

- ◆ Install the balancershaft in head "2" (rear), see 6.15 [ASSEMBLING HEAD "2" (REAR) CAMSHAFT].
- ◆ Inspect the ball bearing (4) for pitting or roughness.
- ◆ Install the bearing in the cam bearing cap assembly; ensure that it slides smoothly in its bore.

NOTE Oil the ball bearings with motor oil before performing this check.

If the ball bearing inner race does not turn easily and silently, or if you detect any roughness or pitting, the bearing must be replaced.

- ◆ Check the oil seal (5) for any signs of wear or damage. Replace if in any way defective.

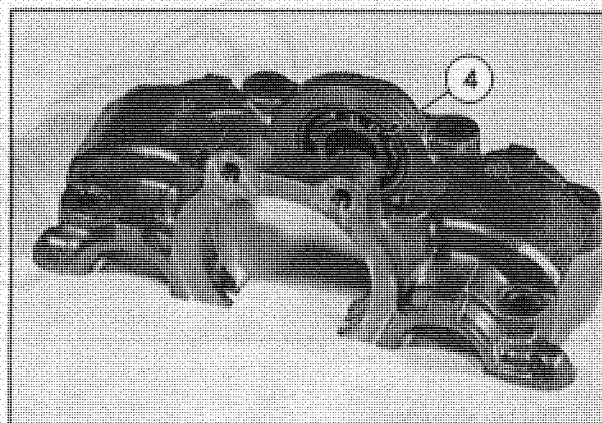
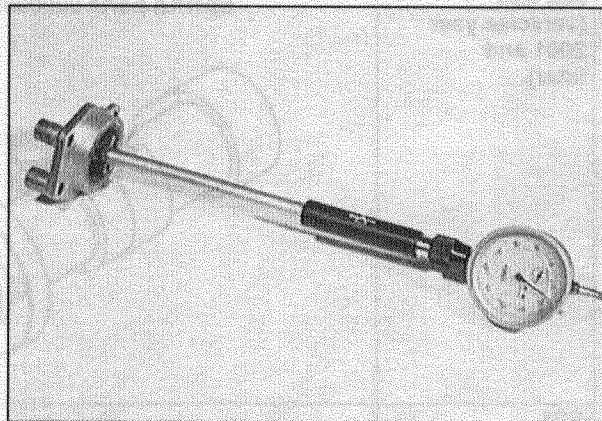
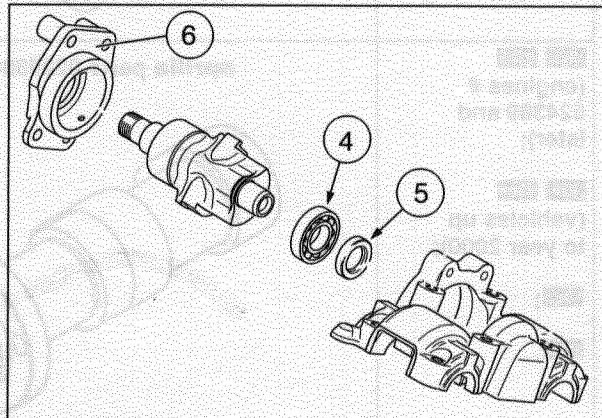
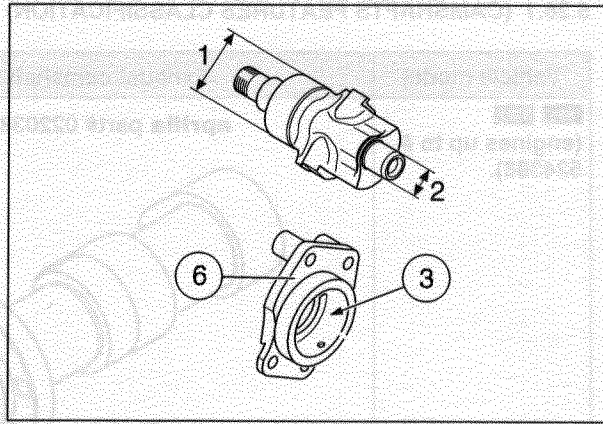

5.28 DISASSEMBLING AND REASSEMBLING THE UPPER BALANCESHAFT BALL BEARINGS AND OIL SEAL

Carefully read 5.1 (PREFACE).

NOTE Have the appropriate special tool **OPT** available:

- **aprilia** part# 0277265 (balanceshaft bearings - main shaft bearings - countershaft bearings, puller) (6);
- **aprilia** part# 0877650 (handle for drift) (7);
- **aprilia** part# 0277660 (upper balanceshaft oil seal assembly drift) (8).

- ◆ Heat the camshaft bearing cap assembly to approximately 80 – 100 °C (176 – 212 °F) .

NOTE This assembly is fragile. Handle with care. Be sure that it is not damaged.

- ◆ Remove the ball bearings (4) with the puller (6) and with the expansion sleeve suitable for this bearing.

NOTE As a rule, the ball bearings and the oil seals should be replaced.

- ◆ Lift the oil seal (5).

NOTE Before assembling, oil the external diameter of the oil seal slightly.

The closed side of the oil seal must face outwards. Grease the sealing lips.

CAUTION

In order to avoid damaging the ball bearing, under no circumstances should the oil seal touch the bearing inner race.

- ◆ Insert the oil seal (5) all the way in using the assembly drift (8).
- ◆ Oil the external diameter of the ball bearing (4) slightly and insert it all the way onto the outer race with a suitable assembly drift.
- ◆ Check the ball bearing housing (4) on the cam bearing cap assembly for wear, distortion, or scoring.

Interference (X) (diameter A – diameter A1):
min. (tight) 0.0012 in (0.030 mm).

CAUTION

Replace if any defect is present.

N = Multi-purpose grease bp lz.

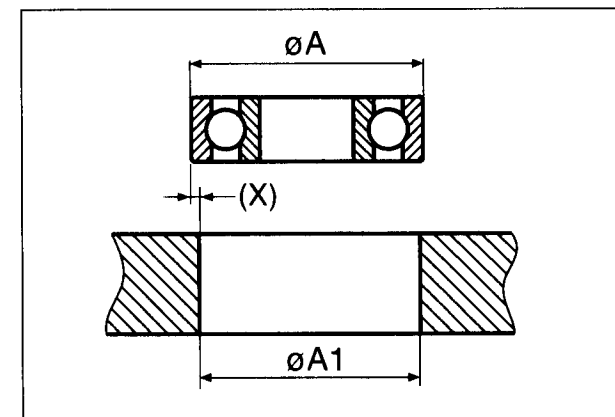
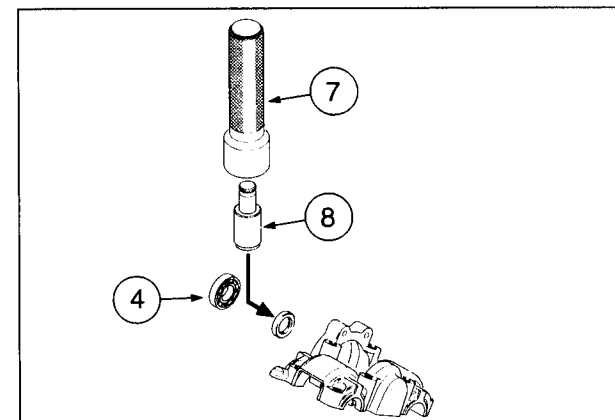
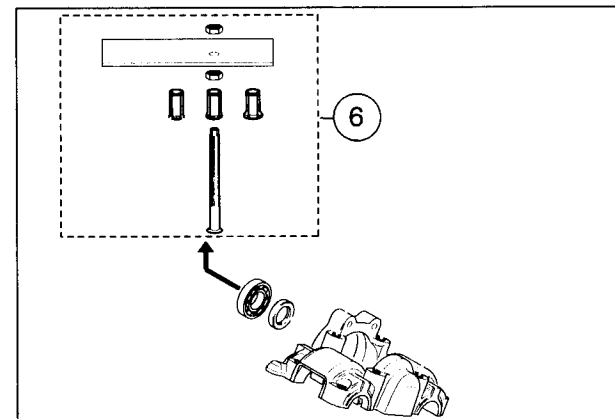
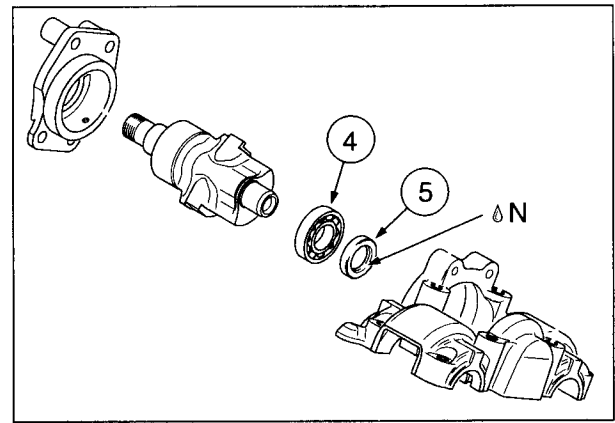

5.29 VALVE GUIDES

Carefully read 5.1 (PREFACE).

- ◆ Use a dial gauge to measure the wear of the valve guide (1).

Wear limit (2): max. Ø 0.238 in (6.05 mm).

NOTE If the valve guide is worn, it can be replaced.

5.29.1 DISASSEMBLY AND REASSEMBLY

- ◆ Remove the valve spring seat (3) and remove the valve spring shim (4).

NOTE Replace the valve spring seat (3).

- ◆ Using the special reamer (5) as far as the top of the notch (6).

NOTE The sharp edge near the top of the valve guide must be machined away. Otherwise, it will foul the valve guide hole in the head, and destroy the head, as the valve guide is removed.

NOTE Have the appropriate special tool **OPT** available:
 – **aprilia** part# 0277510 (valve guide disassembly drift) (7).

NOTE Do not heat the head.

- ◆ Use the drift (7) to remove the rest of the valve guide in the direction of the exhaust manifold.
- ◆ Check the valve guide hole for scoring or damage.

NOTE Should you see any signs of galling, you must replace the head.

Follow ►

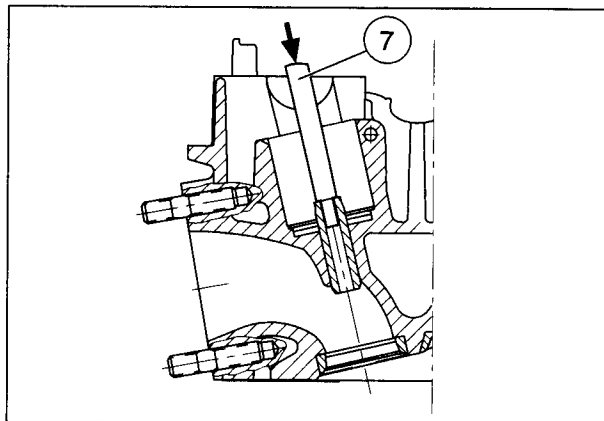
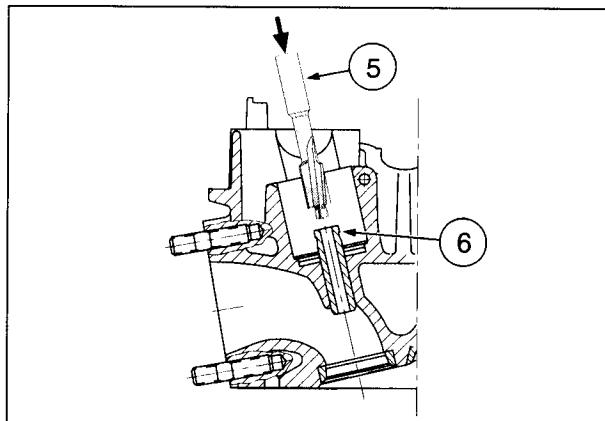
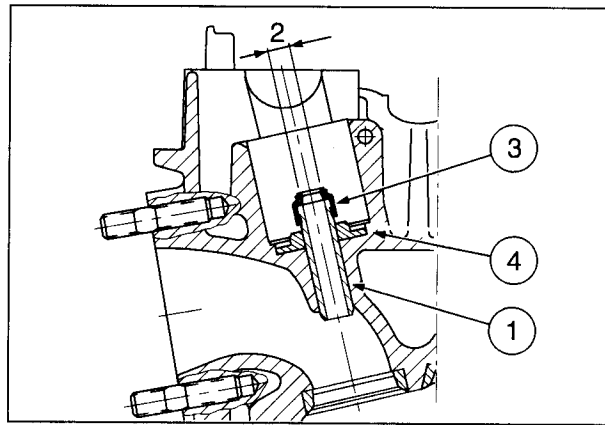

Follow ►

CAUTION

Always apply the MOLYKOTE® G-N on the head hole and on the valve guide assembly edge.
Failure to observe this caution cause damage to the head and valve guide.

- ◆ Always apply MOLYKOTE® G-N to the bore in the head and the outside of the valve guide, before assembly.

NOTE Have appropriate the special tool **OPT** available:
– **aprilia** part# 0277695 (valve guide oil seal assembly drift) (8).

- ◆ Using the assembly drift (8), insert the new valve guide in the head, working from the top of the head towards the combustion chamber, until the assembly drift (8) bottoms against the head.

NOTE The exhaust valve and intake valve guides are different.
The intake valve guide is longer, with a longer finished surface.

- ◆ Check how much the head of the valve guide protrudes (10) on the camshaft side.

Protrusion (10) = 0.52 ± 0.008 in (13.3 ± 0.2 mm).

- ◆ Carefully ream the valve guide to size using an adequate reamer.

Valve guide inside diameter: 0.2365 – 0.2369 in (6.006 – 6.018 mm).

NOTE Use only cutting fluid to lubricate the reamer.
The reamer should be turned in only the cutting direction, never backwards. Clean chips from the reamer frequently, remembering always to rotate the reamer only in the cutting direction.

- ◆ Once the valve guides have been properly reamed, clean the head thoroughly. Grind the valve seat (11), smoothing the valve seat with valve seat grinder, see 5.30 (VALVES).
- ◆ Using Prussian blue, check the valve to valve seat contact.

M = MOLYKOTE® G-N.

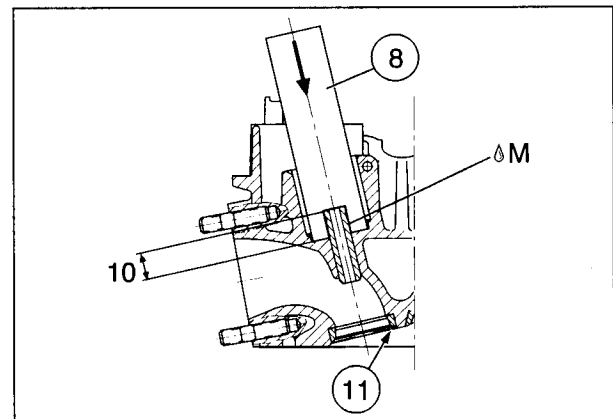
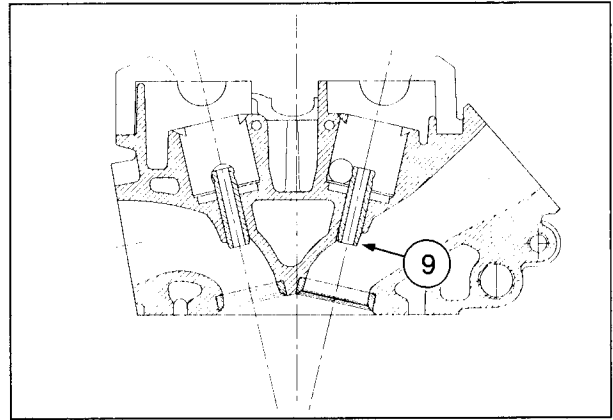

5.30 VALVES

Carefully read 5.1 (PREFACE).

⚠ CAUTION

Replace the valves one by one. Do not mix up the components. Ensure that each valve is replaced in its appropriate seat, as marked, during disassembly.

⚠ CAUTION

These valves have induction hardened heads (1), therefore, the valve must not be reground. If the seating surface of the valve is pitted or warped, the valve must be replaced. Also, the tip of the valve stem is hardened, and therefore must not be ground. However, it is permitted to use a small amount of valve grinding compound to hand finish the valve and valve seat contact surfaces.

- ◆ Carefully clean the valves, removing all carbon and other combustion products.
- ◆ Check the seat of the valve head (1) with a straight edge. The surface of the seat must not be concave. If it is, the valve must be replaced.
- ◆ Measure the diameter of the stem using a micrometer:
 - intake valve:
wear limit (2) min. \varnothing 0.2343 in (5.950 mm);
 - exhaust valve:
wear limit (2) min. \varnothing 0.2337 in (5.935 mm).
- ◆ Check the eccentricity of the valve:
 - valve stem:
permissible eccentricity (3) max. 0.002 in (0.05 mm);
 - valve head:
permissible eccentricity (4) max. 0.002 in (0.05 mm).
- ◆ Check the keeper grooves (5). They must be in perfect condition. In they are not, replace the valve.

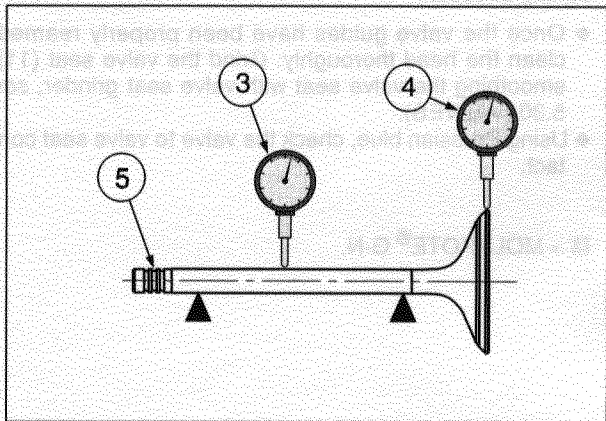
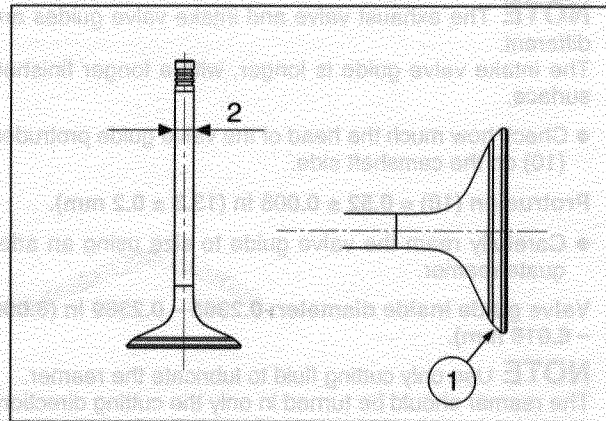

5.30.1 VALVE SPRINGS

- ◆ Measure and visually inspect the valve springs to check for breakage, distortion or loss of tension.
- ◆ Measure the spring's free length:
 - valve spring's free length (6):
wear limit (6) min. 1.71 in (43.4 mm);
 - valve spring's free length (7):
wear limit (7) min. 1.61 in (40.9 mm).

NOTE Weak valve springs may result in valve float and engine damage at high RPM, as well as increased valve rattle and reduced power.

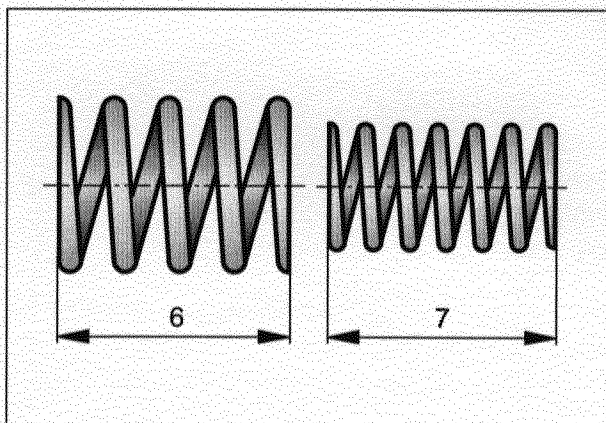

5.30.2 VALVE SEATS

- ◆ Apply a thin film of Prussian blue to the valve seating surface.
- ◆ Insert the valve (1) into the valve guide, holding the valve firmly against the seat, turn the valve through one complete revolution.
- ◆ Check the width of the valve seat (2) (3) and the contact mark, checking for any signs of wear:
 - (vehicles up to year 2000) intake valve wear limit (2) max. 0.063 in (1.6 mm);
 - (vehicles year 2001 and later) intake valve wear limit (2) max. 0.059 in (1.5 mm);
 - exhaust valve: wear limit (3) max. 0.071 in (1.8 mm).

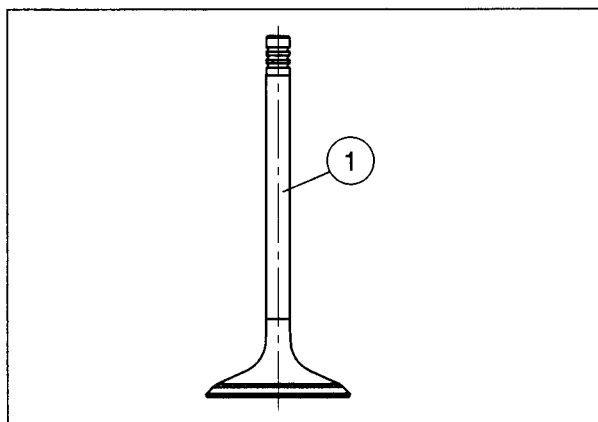

NOTE The circular contact mark on the valve seat and valve surfaces must be continuous and unbroken. If the width of the valve seat exceeds the wear limit or if the valve seat surface is not continuous, the valve seat must be reground.

5.30.3 GRINDING THE VALVE SEATS

- A = intake
- B = exhaust

NOTE The valve seats may be reground with a valve seat grinder which centers on the valve guide.

- ◆ Grind the valve seat at 45°. Remove no more material than absolutely necessary to clean the seat up.
- ◆ Using a 35° stone, narrow the valve seat until the appropriate outer diameter (4) (5) is obtained:
 - (vehicles up to year 2000) intake valve diameter (4) Ø 1.39 in (35.3 mm);
 - (vehicles year 2001 and later) intake valve diameter (4) Ø 1.48 in (37.7 mm);
 - exhaust valve (5) Ø 1.19 in (30.3 mm).

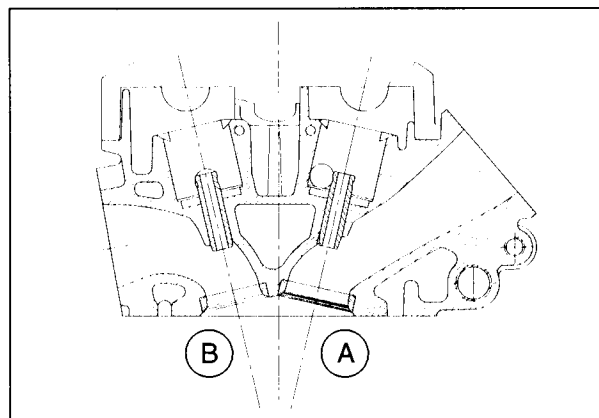

Working on the intake valve:

- ◆ Using:
 - (vehicles up to year 2000) a 50° stone;
 - (vehicles year 2001 and later) a 55° stone;
 reduce the width of the seating surface until the appropriate value (6) is obtained:
 - (vehicles up to year 2000) intake valve value (6) 0.041 – 0.053 in (1.05 – 1.35 mm);
 - (vehicles year 2001 and later) intake valve value (6) 0.039 – 0.055 in (1.00 – 1.40 mm).

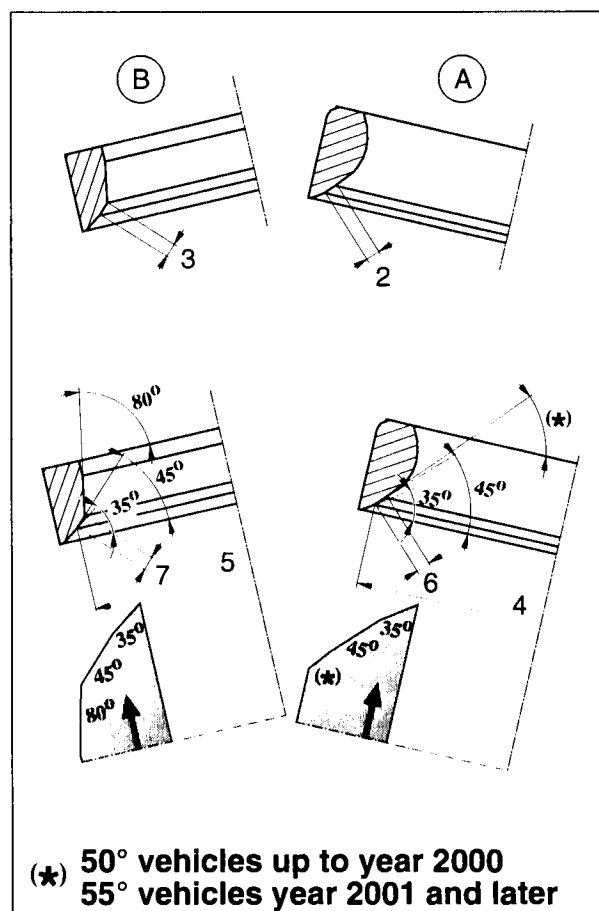

Working on the exhaust valve:

- ◆ Using an 80° stone, reduce the width of the seating surface until the appropriate value (7) is obtained:
 - exhaust valve value (7) 0.049 – 0.061 in (1.25 – 1.55 mm).
- ◆ Finally, coat the valve head sealing seating surface with a fine paste of valve grinding compound using a manual valve grinding mandrel. Lightly grind the valves until a smooth, even, uniform sealing surface of the appropriate inside and outside diameter is obtained on both the valve and the seat. For this final valve seat finishing operation, do not use an electric drill or other motorized device. Use only a hand held valve grinding mandrel with a suction cup, rotating the valve back and forth through about 45°, and then advancing the valve 45° before repeating this operation.

5.30.4 ASSEMBLING THE VALVES IN THE HEAD

NOTE The following information refers to a single valve, but is valid for all of them.

CAUTION

Replace the valve units one by one.
Do not mix up components belonging to different valve units.

Replace each valve unit in the corresponding seat marked upon disassembly.

NOTE Have the appropriate special tool **OPT** available:

- aprilia part# 0277210 (valve guide assembly drift) (3);
- aprilia part# 0276479 (valves spring-pusher tool) (8);
- aprilia part# 8140179 (valves disassembly and reassembly clamp) (9).

- ◆ Place the valve spring seat (1) over the valve guide.
- ◆ Fit a new valve stem oil seal (2) with the appropriate assembly drift (3).
- ◆ Turn the head over.

NOTE When inserting the valve (4), take care not to damage the new valve stem oil seal (2).

- ◆ Apply motor oil to the valve stem and insert the valve (4) into the appropriate guide.

NOTE Ensure that the valve stem oil seal (2) is positioned correctly.

- ◆ If you have a Bosch or Sun tester available, check the valve leakage.

NOTE If it is less than 5%, the valves are properly seated.

- ◆ Turn the head over.
- ◆ Install the valve springs (5) (6) and the valve spring collar (7).

NOTE Be sure to install the valve springs properly. Remember that the more tightly wound coils are next to the head.

CAUTION

Do not compress the valve springs any more than is absolutely necessary, as this could damage the spring. Compress the springs only as much as necessary to fit the valve keepers in their seat on the valve.

- ◆ Compress the valve springs (5) and (6), complete with cup (7), by means of the valve spring compressor (8) and the appropriate clamp (9).

NOTE Apply some grease to the valve keepers (10), in order to facilitate their assembly.

- ◆ Insert the valve keepers (10) in the groove (11) on the valve (4).

NOTE When releasing the clamp (9), ensure that the valve keepers (10) are perfectly inserted in the valve groove (11); if necessary, use a plastic hammer and proceed with care.

- ◆ Remove the compressor (8) and the clamp (9).

CAUTION

Ensure that the valve springs are placed correctly. If the springs are oblique, they will inevitably cause the breakage of the valve stem.

- ◆ Repeat the operations for the second valve.
- ◆ After reassembling the valves, check valve leakage using a special cylinder head leakage tester (Bosch or Sun).

NOTE If the leakage is less than 5%, the valves and valve seats are in satisfactory condition.

O = Engine oil.

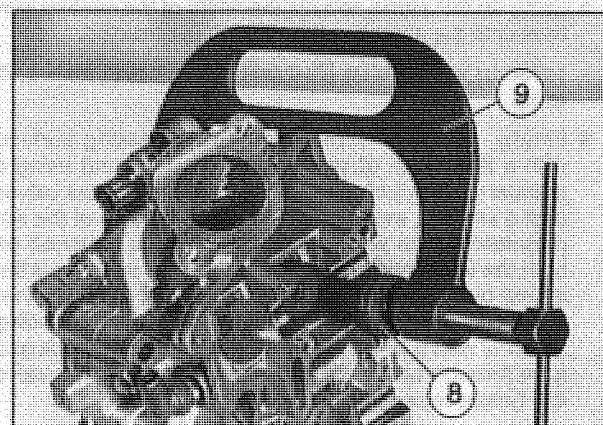
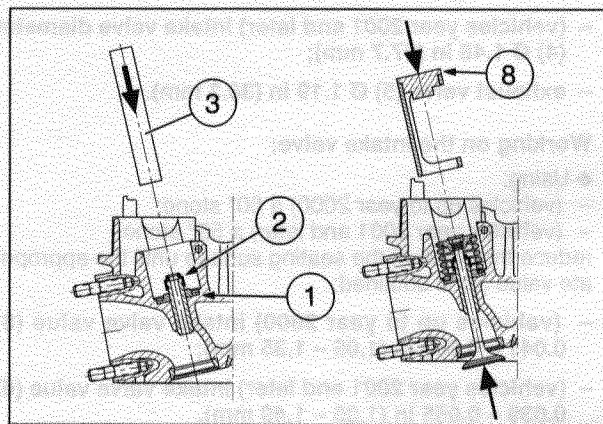
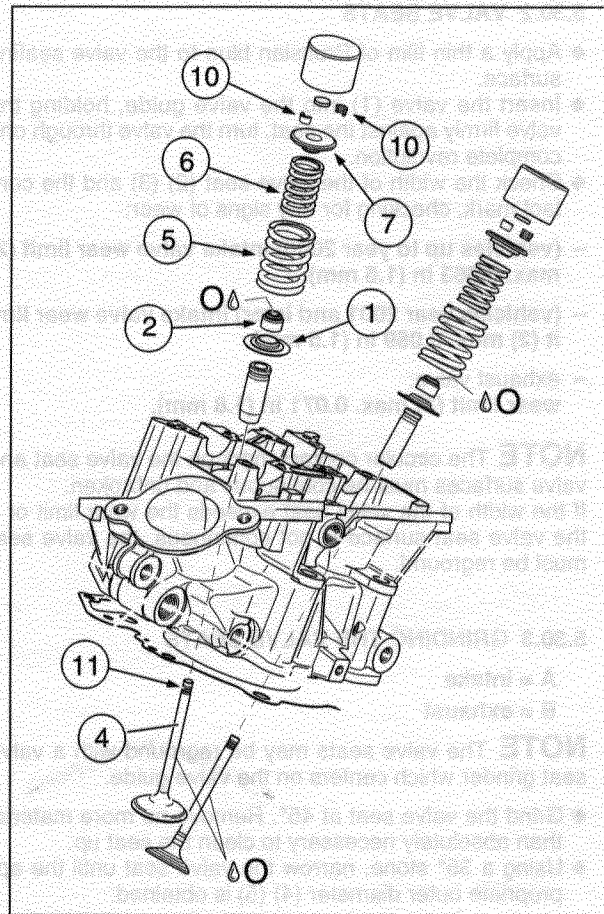

5.31 CYLINDER

Carefully read 5.1 (PREFACE).

◆ Before reassembly, all gasket surfaces must be completely clean, and flat. Flatness of the gasket surfaces:

Max. permissible distortion: 0.0016 in (0.04 mm).

- ◆ Ensure that all the threads are in a perfect state of repair.
- ◆ Inspect the cylinder bore. Slight up and down scoring is permissible, but if there are deep gouges, scoring or galling in the lining of the cylinder, the complete cylinder, along with the piston, must be replaced.
- ◆ Inspect the cooling passages. Remove any mineral deposits.
- ◆ Measure the bore of the cylinder in three places at a distance of **1.77 in (45 mm)** from the upper edge (1). The largest diameter measured must be less than the wear limit:

NOTE The size group "A" or "B" is stamped onto the lower side of the cylinder (2).

- size group "A", dimension when new:
bore \varnothing 3.8976 – 3.8193 in (97.000 – 97.012 mm);
wear limit: max. \varnothing 3.8199 in (97.027 mm).
- size group "B", dimension when new:
bore \varnothing 3.8193 – 3.8198 in (97.012 – 97.025 mm);
wear limit: max. \varnothing 3.8205 in (97.040 mm).

NOTE In order to assess the wear limit, the assembly play must be determined, see 5.32 (PISTON AND GUIDGEON PIN).

- ◆ Ensure that the chain tightener (3) and guide in the cylinder are in perfect condition.

Chain tightener (3) / hole (4) on the cylinder clearance:
wear limit (hole diameter - chain tightener diameter):
max. 0.003 in (0.08 mm);

Hole for chain tightener in the cylinder:
wear limit (4): max. \varnothing 0.554 in (14.07 mm).

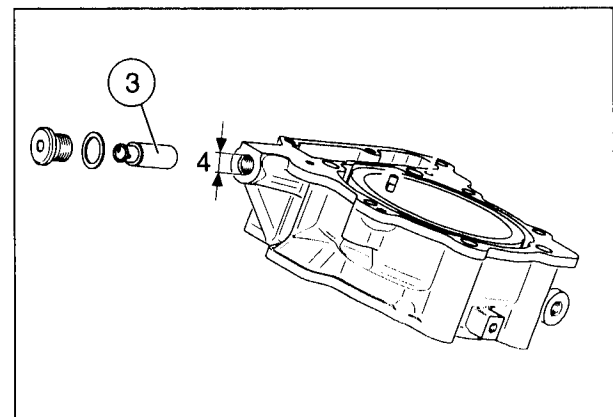
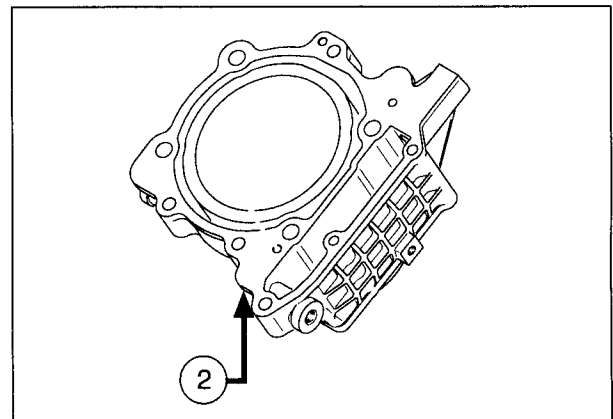
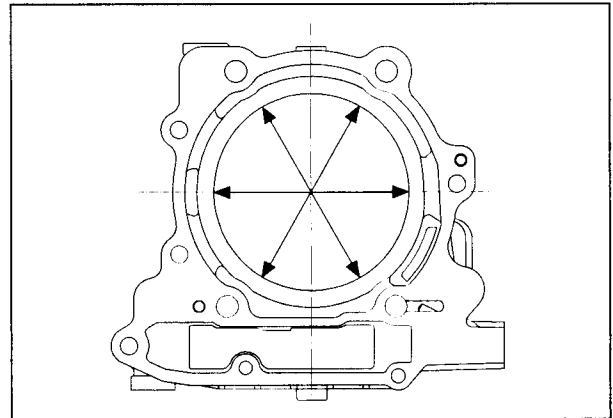
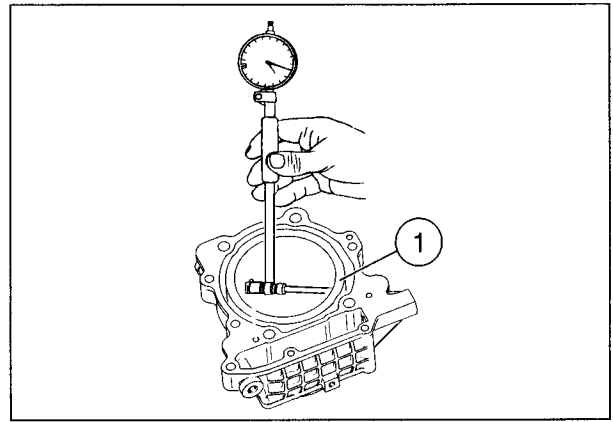

5.32 PISTON AND GUDGEON PIN

Carefully read 5.1 (PREFACE).

- ◆ Clean the piston crown (1) and the area above the upper piston ring (2) carefully to remove any residual combustion products.
- ◆ Inspect the piston carefully for cracking, discoloration, galling or seizing. Particularly inspect the skirts of the piston for any signs of galling on the cylinder. If there is any sign of metal transfer from cylinder to piston or piston to cylinder, both the cylinder and the piston must be replaced, see 5.32.1 (PISTONS FEATURES CLASSIFICATION).

NOTE Small up and down scratches on the piston skirt that do not show any sign of metal transfer or galling are acceptable.

- ◆ Measure the piston diameter 0.39 in (10 mm) (3) above the bottom of the piston, and at right angles to the gudgeon pin.

- "red" piston:
wear limit, min. diameter Ø 3.8145 in (96.890 mm);
- "green" piston:
wear limit, min. diameter Ø 3.8149 in (96.900 mm);
- piston play - measurement:
piston play = cylinder diameter minus piston diameter
wear limit max. 0.0047 in (0.120 mm).

NOTE If the wear limit is exceeded, a new piston must be used or the cylinder replaced, complete with piston. If the piston is replaced, the two circlips securing the gudgeon pin must always be replaced, along with the actual gudgeon pin.

Take special care when matching the cylinder - piston:

- "red" piston - Cylinder "A";
- "green" piston - Cylinder "B".
- ◆ Using an inside micrometer, measure the diameter of the gudgeon pin hole in the piston in the up and down direction. Make several measurements at different locations along the gudgeon pin hole:
 - gudgeon pin hole in the direction of lift:
wear limit (4) max. Ø 0.8668 in (22.018 mm);
 - gudgeon pin:
wear limit (5) min Ø 0.8661 in (21.998 mm).
- ◆ Carefully inspect the circlips and relevant grooves (6) on the piston which hold the gudgeon pin in the piston.

NOTE We recommend you never replace a gudgeon pin circlip. They should always be renewed whenever they are disassembled.

Follow ►

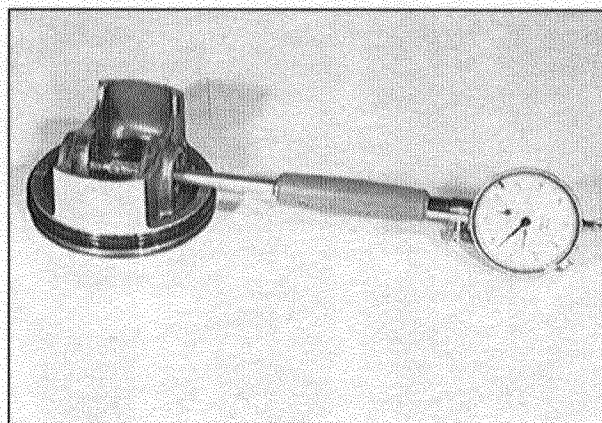
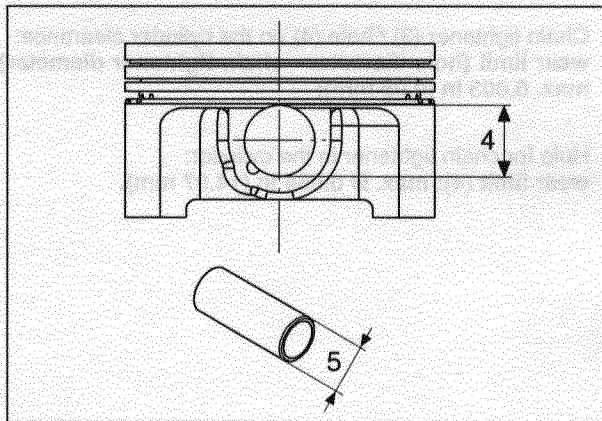
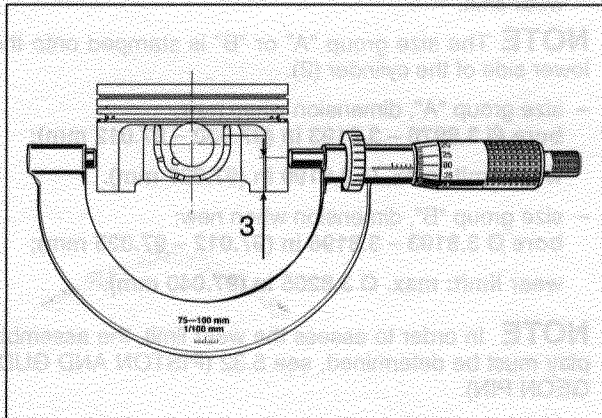
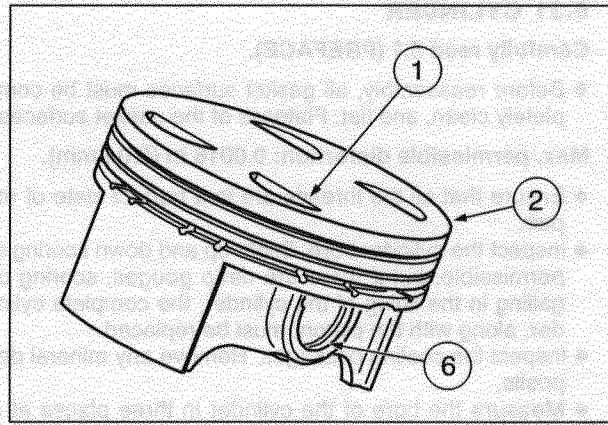

Follow ►

- ◆ Use a feeler gauge to measure the end play (7) (8) (9) of the piston rings inside the grooves.
- “L-section” ring
wear limit (7) max. 0.0047 in (0.12 mm);
- tapered protruding ring:
wear limit (8) max. 0.0047 in (0.12 mm);
- oil ring
wear limit (9) max. 0.0039 in (0.10 mm).

CAUTION

The piston rings are fragile.

- ◆ Carefully remove the piston rings from the piston.

NOTE The piston ring groove can be cleaned using a scraper or an old piston ring.

- ◆ Clean the piston rings and the oil return holes (10) and the oil ring groove, carefully blow out the oil return holes.
- ◆ Check the oil ring (11), the tapered protruding ring (12) and the L-section ring (13) to ensure that they rotate freely in the piston, and that there are no scores, scrapes, discolorations or carbon deposits on the bearing surface of the piston rings.
- ◆ Measure the piston ring gap (14) with a feeler gauge.

wear limit max. 0.039 in (1.00 mm).

NOTE In order to measure the gap required, insert the piston ring in the cylinder and push it inside so that it is lined up with the piston.

- ◆ Measure the thickness of the rings with a micrometer:

- “L-section” ring:
wear limit (15) min. 0.033 in (0.85 mm);
- tapered protruding ring:
wear limit (16) min. 0.047 in (1.20 mm);
- oil ring:
wear limit (17) min. 0.096 in (2.45 mm).

- ◆ Fit the oil ring (11), the tapered protruding ring (12) and the “L-section” ring (13) from the bottom up; the word “TOP” on the rings must face up.

NOTE Rotate the piston rings so that the three gaps are staggered by approx. 120°.

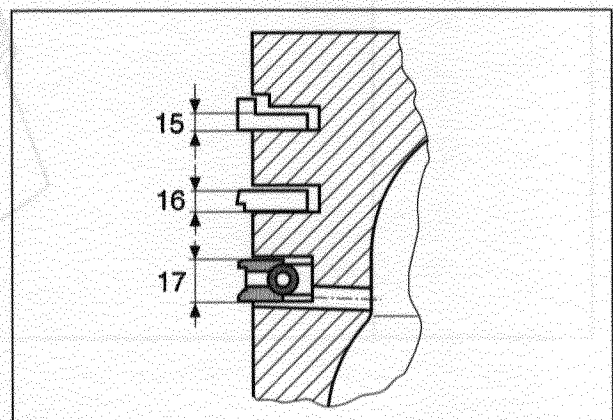
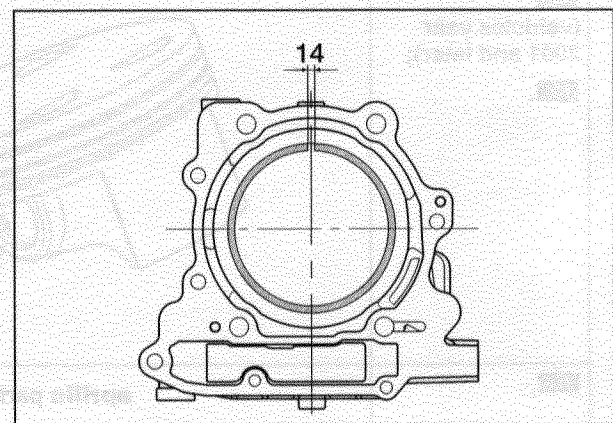
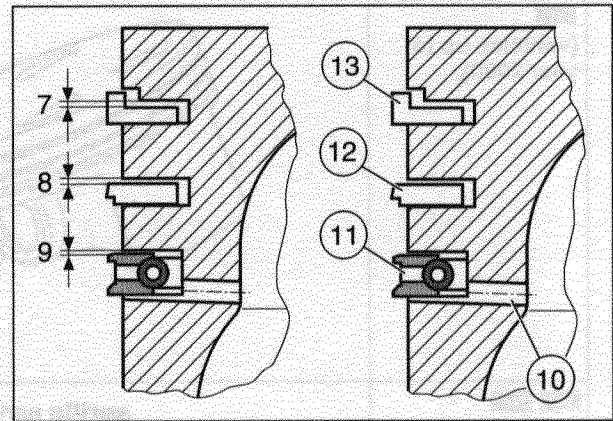
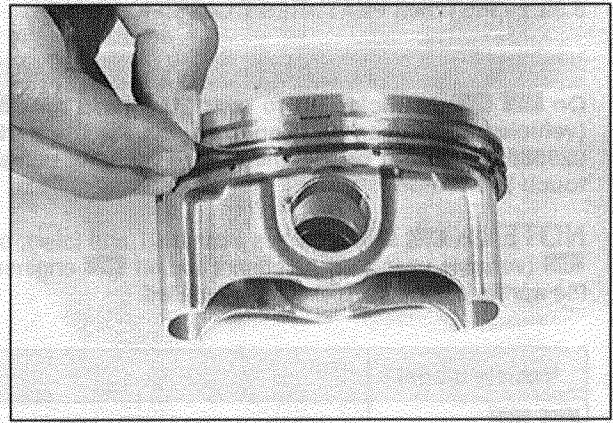

5.32.1 (PISTONS FEATURES CLASSIFICATION)

CAUTION

On **RSV** **RSV R** (vehicles up to year 2000) and on **SL** (vehicles up to year 2000) engines, the **aprilia** part# 0295855 must not be installed since the inlet valves touch this piston.

NOTE On **RSV** **RSV R** (vehicles year 2001 and later), on **SL** (vehicles year 2001 and later) and on **RST** engines, the **aprilia** part# 0295852 can be installed.

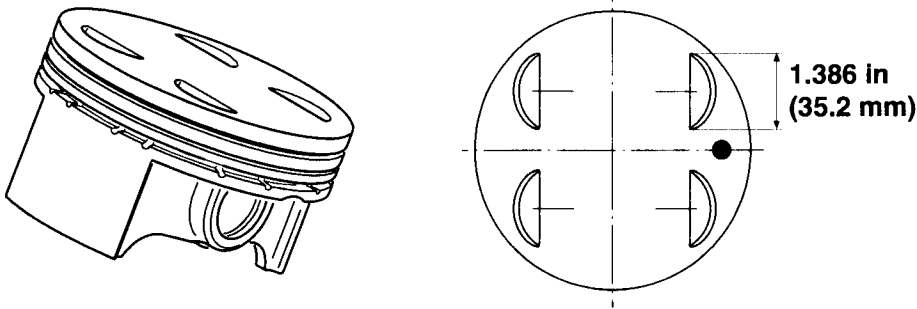
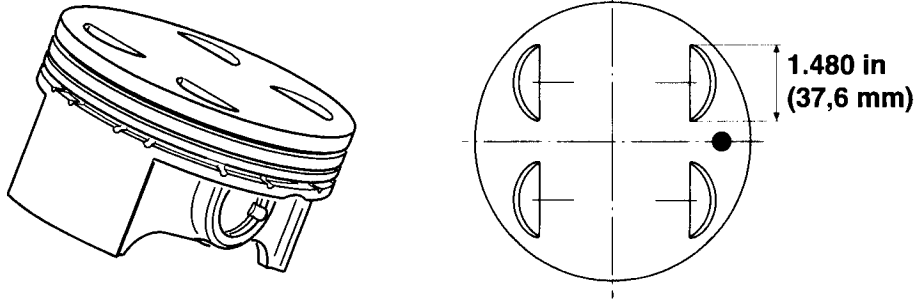
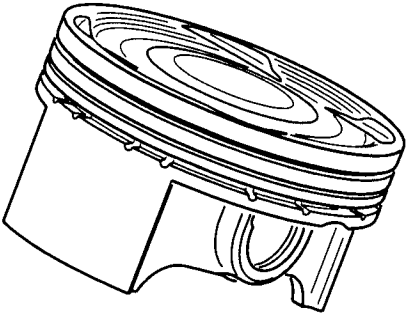
Vehicle model	Pistons
<p>RSV RSV R (vehicles up to year 2000); SL (vehicles up to year 2000).</p>	<p>aprilia part# 0295855 (piston and piston rings set).</p> 
<p>RSV RSV R (vehicles year 2001 and later); SL (vehicles year 2001 and later); RST.</p>	<p>aprilia part# 0295852 (piston and piston rings set).</p> 
<p>ETV.</p>	<p>aprilia part# 0296590 (piston and piston rings set).</p> 

5.33 STARTER MOTOR DRIVE ASSEMBLY

Carefully read 5.1 (PREFACE).

◆ Remove the starter double gear (1), starter idler gear (2) and the sprag clutch gear (3), see 4.8 (REMOVING THE ALTERNATOR COVER AND ALTERNATOR SYSTEM).

◆ Measure:

- the gear bearing diameter (A) of the starter double gear (1):
wear limit: max.Ø 0.398 in (10.10 mm);
- the gear bearing diameter (B) of the starter idler gear (2):
wear limit: max.Ø 0.397 in (10.08 mm);
- the gear bearing diameter (C) of the sprag clutch gear (3):
wear limit: max.Ø 1.381 in (35.07 mm).

◆ Inspect:

- the teeth (D) and (E) of the starter double gear (1);
- the teeth of the starter idler gear (2);
- the teeth of the sprag clutch gear (3);

for wear, pitting, distortion or discoloration.

NOTE If the teeth (D) of the starter double gear (1) are distorted, pitted or damaged in any way, the starter motor pinion (F) must also be inspected.

- ◆ Inspect the surface of the starter double gear (1), starter idler gear (2) and the sprag clutch gear (3) for wear, pitting, distortion or discoloration.
- ◆ Inspect the bore of the bushing (G) in the sprag clutch gear (3) for signs of scoring or galling.

NOTE The bushing (G) in the sprag clutch gear (3) is an interference fit, and must not move in the gear.

- ◆ Inspect the contact surface (H) of the sprag clutch for wear, pitting, distortion, or discoloration.

CAUTION

If the contact surface (H) is damaged in any way, the sprag clutch gear (3) must be replaced.

- ◆ Check the sprag clutch, see 5.34.6 (CHECKING THE SPRAG CLUTCH **RSV** **RSV B** **SL**) or 5.35.6 (CHECKING THE SPRAG CLUTCH **RST** **ETV**).

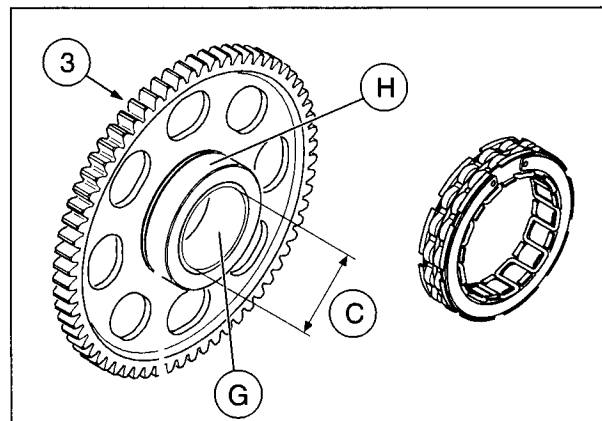
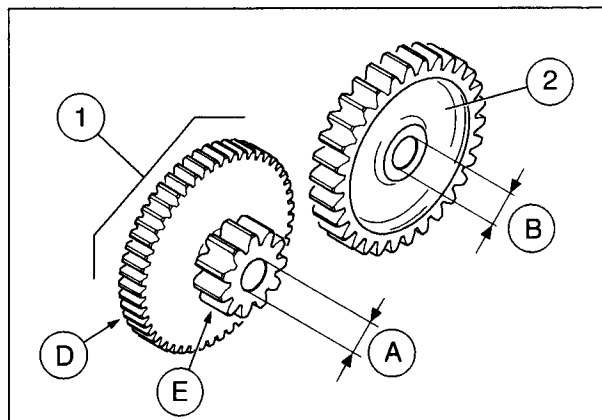
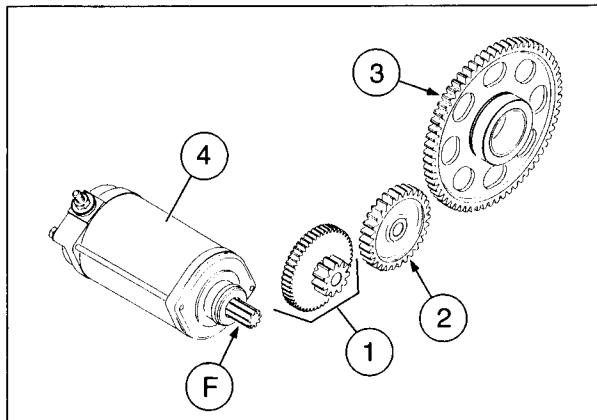

5.34 ALTERNATOR RSV RSV R SL

Carefully read 5.1 (PREFACE).

NOTE The alternator produces alternating current which is then transformed into direct current by the regulator/rectifier, which then charges the battery.

▲ WARNING

When performing work on the alternator:

- switch off the engine;

- disconnect the battery: always disconnect the negative pole (–) first;
- drain the engine oil tank completely, see section 2 (SERVICE AND SETTING UP) of specific vehicle workshop manual see 0.4.1 (VEHICLE WORKSHOP MANUAL).
- lock the crankshaft at the TDC of piston “1” or “2”.

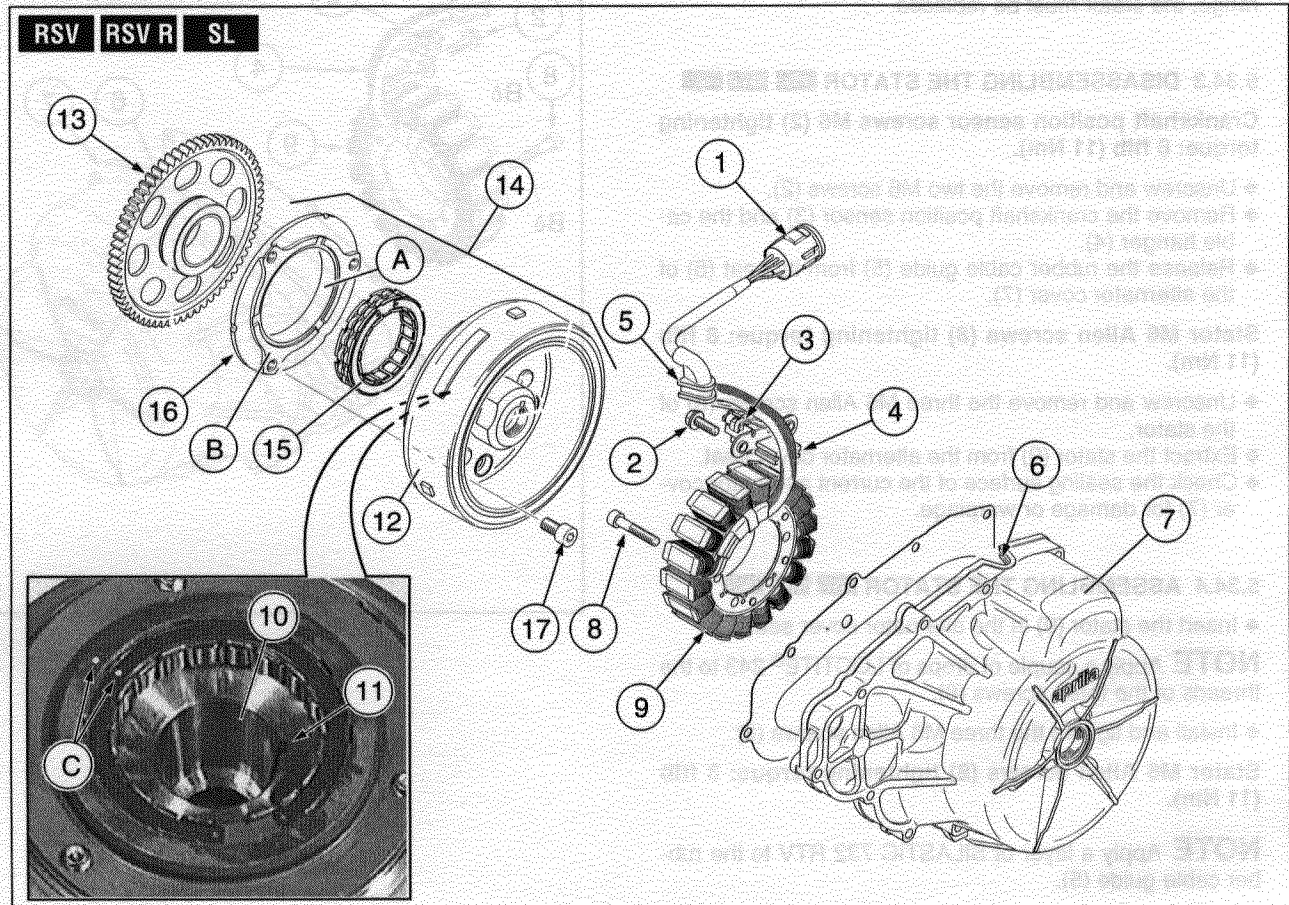
**Key**

- | | |
|--|---|
| 1) Alternator connector. | 12) Alternator rotor. |
| 2) # two screws of crankshaft position sensor. | 13) Sprag clutch gear. |
| 3) Crankshaft position sensor. | 14) Alternator rotor group. |
| 4) Cable hanger. | 15) Sprag clutch. |
| 5) Rubber cable guide. | 16) Sprag clutch flange. |
| 6) Seat of rubber cable guide. | 17) # three Allen screws of sprag clutch flange. |
| 7) Alternator cover. | A) Inside contact land of sprag clutch flange. |
| 8) # three Allen screws of stator. | B) Contact flat surface of sprag clutch flange with alternator rotor. |
| 9) Stator. | C) Reference dot (for correct reassembly). |
| 10) Alternator rotor taper. | |
| 11) Key seat. | |

5.34.1 TO GAIN ACCESS TO THE ALTERNATOR RSV RSV R SL

- ◆ Remove the alternator cover (7) with:
 - stator (9);
 - crankshaft position sensor (3);

see 4.8 (REMOVING THE ALTERNATOR COVER AND ALTERNATOR SYSTEM).

5.34.2 CHECKING THE STATOR **RSV RSV R SL**

CAUTION

Do not force the electric cables.

- ◆ Measure the resistance between the three yellow cables of the alternator connector (1) using an ohmmeter.
- Standard resistance value in the range 0.2 – 0.5 Ω at 20 °C (68 °F).

NOTE If the resistance value does not fall within this range, the stator must be replaced.

5.34.3 DISASSEMBLING THE STATOR **RSV RSV R SL**

Crankshaft position sensor screws M6 (2) tightening torque: 8 ftlb (11 Nm).

- ◆ Unscrew and remove the two M6 screws (2).
- ◆ Remove the crankshaft position sensor (3) and the cable hanger (4).
- ◆ Release the rubber cable guide (5) from its seat (6) of the alternator cover (7).

Stator M6 Allen screws (8) tightening torque: 8 ftlb (11 Nm).

- ◆ Unscrew and remove the three M6 Allen screws (8) of the stator.
- ◆ Extract the stator (9) from the alternator cover seat.
- ◆ Check the sealing surface of the current alternator cover (7) for damage or warpage.

5.34.4 ASSEMBLING THE STATOR **RSV RSV R SL**

- ◆ Insert the stator (9) in the alternator cover seat.

NOTE Apply a couple of drops of LOCTITE® 243 to the threads of the three screws (8).

- ◆ Install and tighten the three M6 Allen screws (8).

Stator M6 Allen screws (8) tightening torque: 8 ftlb (11 Nm).

NOTE Apply a layer of SILASTIC 732 RTV to the rubber cable guide (5).

- ◆ Insert the rubber cable guide (5) in the seat (6) of the alternator cover (7).
- ◆ Correctly place the cable hanger (4) and the crankshaft position sensor (3).

NOTE Apply a couple of drops of LOCTITE® 243 to the threads of the two screws (2).

- ◆ Install and tighten the two M6 screws (2).

Crankshaft position sensor M6 screws (2) tightening torque: 8 ftlb (11 Nm).

Q = SILASTIC 732 RTV.
B = LOCTITE® 243.

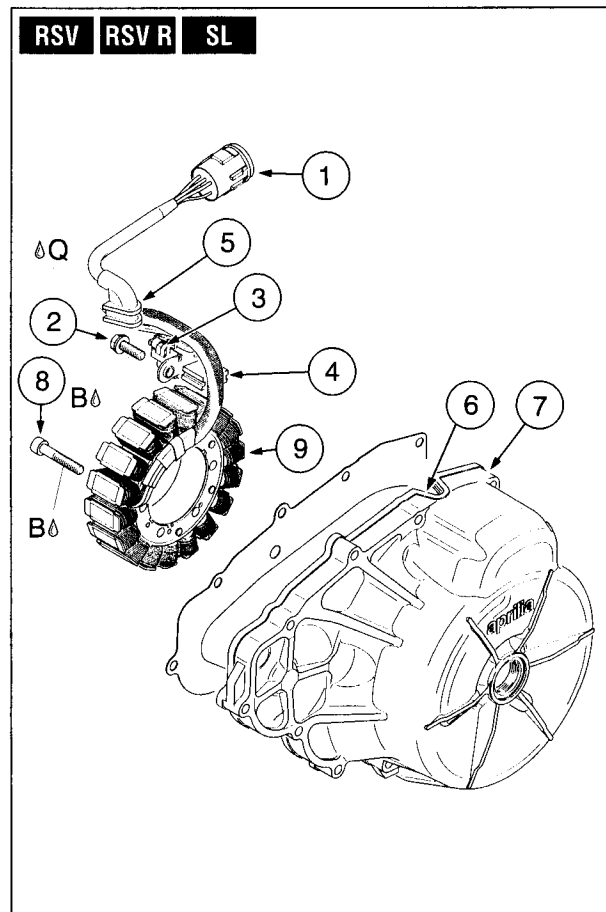

5.34.5 ALTERNATOR ROTOR RSV RSV R SL

- ◆ Clean the alternator rotor taper (10) thoroughly. Remove any LOCTITE® residue.
- ◆ Ensure that the taper (10) and the key seat (11) are in perfect condition.

NOTE If the taper (10) or the key seat (11) are damaged, the alternator rotor (12) must be replaced.

5.34.6 CHECKING THE SPRAG CLUTCH RSV RSV R SL

- ◆ Check the sprag clutch gear (13), see 5.33 (STARTER MOTOR DRIVE ASSEMBLY).
- ◆ Clean the alternator rotor taper (10) thoroughly. Remove any LOCTITE® residue.
- ◆ Correctly install the sprag clutch gear (13) on the alternator group (14).

CAUTION

The sprag clutch gear (13) must rotate smoothly without jerkiness or roughness and in one-way only.

- ◆ Manually turn the sprag clutch gear (13), it rotate move smoothly without jerkiness or roughness and in one-way only.

If the sprag clutch gear display any of these signs:

- ◆ Withdraw the sprag clutch gear (13) from the alternator group (14).
- ◆ Extract the sprag clutch (15), see 5.34.7 (DISASSEMBLING THE SPRAG CLUTCH RSV RSV R SL).
- ◆ Inspect the sprag clutch (15):
 - the rollers of the sprag clutch for wear, galling, pitting, or discoloration;
 - the external helical spring preload must be sufficient to hold the rollers snugly in place.
- ◆ Inspect the inside contact land (A) of sprag clutch flange (16):
 - for wear, galling, pitting, or discoloration.

NOTE If the inside contact land (A) is damaged, the complete sprag clutch flange (16) must be replaced.

5.34.7 DISASSEMBLING THE SPRAG CLUTCH RSV

RSV R SL

Sprag clutch flange M8x16 Allen screw tightening torque: 21.7 ftlb (30 Nm).

- ◆ Unscrew and remove the three M8x16 Allen screws (17).

CAUTION

Before removing the sprag clutch flange (16) mark it and the sprag clutch (15) with a dot (C), to remind you which direction them should be reassembled and so that you are sure to refit the sprag clutch (15) with the same direction of rotation.

- ◆ Using a felt pen, mark the sprag clutch flange (16) and the sprag clutch (15) with a dot (C).
- ◆ Detach the sprag clutch flange (16) from the alternator rotor (12).
- ◆ Remove the sprag clutch (15) from its seat, on the sprag clutch flange (16).

5.34.8 ASSEMBLING THE SPRAG CLUTCH RSV RSV R SL**CAUTION**

When replacing the sprag clutch (15) observe the reference dot (C) as marked upon disassembly.

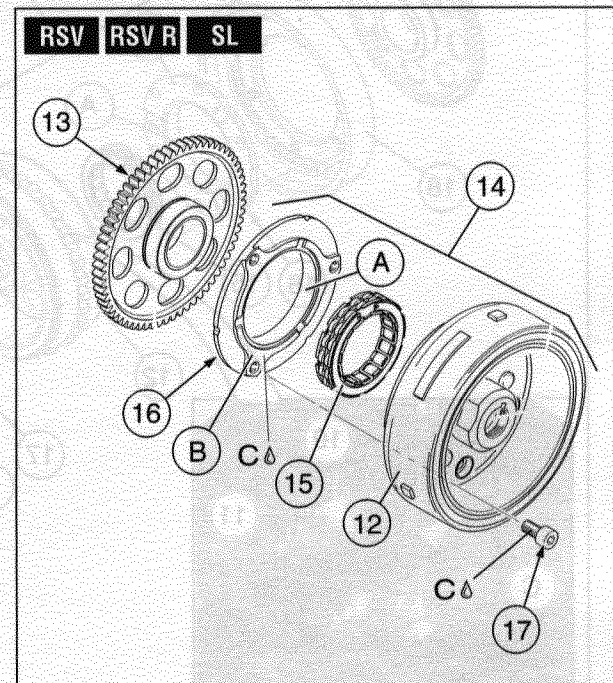
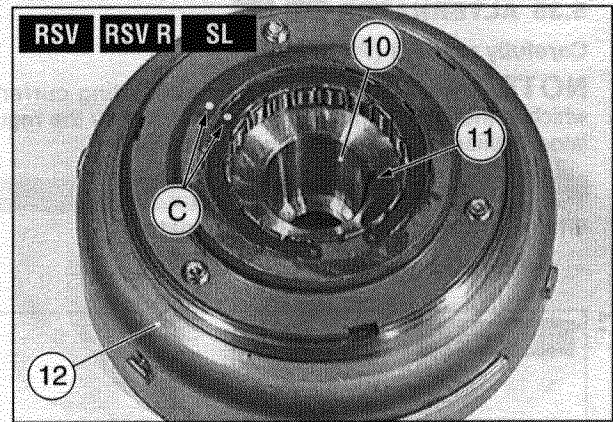

- ◆ Correctly insert the sprag clutch (15) in its seat, on the sprag clutch flange (16). Refer to the reference dot (C) applied during disassembly.

CAUTION

Use LOCTITE® 648 on the contact flat surface (B) of the sprag clutch flange (16) with alternator rotor.

- ◆ Apply a couple of drops of LOCTITE® 648 to the contact flat surface (B) of the sprag clutch flange (16) and correctly place it in the center of the alternator rotor (12).

CAUTION

Use LOCTITE® 648 on the three M8x16 Allen screws (17) of the sprag clutch flange (16).

- ◆ Apply a couple of drops of LOCTITE® 648 to the threads of the M8x16 Allen screws (17).
- ◆ Screw in and tighten the three M8x16 Allen screws (17).

Sprag clutch flange M8x16 Allen screw tightening torque: 21.7 ftlb (30 Nm).

C = LOCTITE® 648.

5.35 ALTERNATOR RST ETV

Carefully read 5.1 (PREFACE).

NOTE The alternator produces alternating current which is then transformed into direct current by the regulator/rectifier, which then charges the battery.

WARNING

When performing work on the alternator:

- switch off the engine;

- disconnect the battery: always disconnect the negative pole (-) first;
- drain the engine oil tank completely, see section 2 (SERVICE AND SETTING UP) of specific vehicle workshop manual see 0.4.1 (VEHICLE WORKSHOP MANUAL).

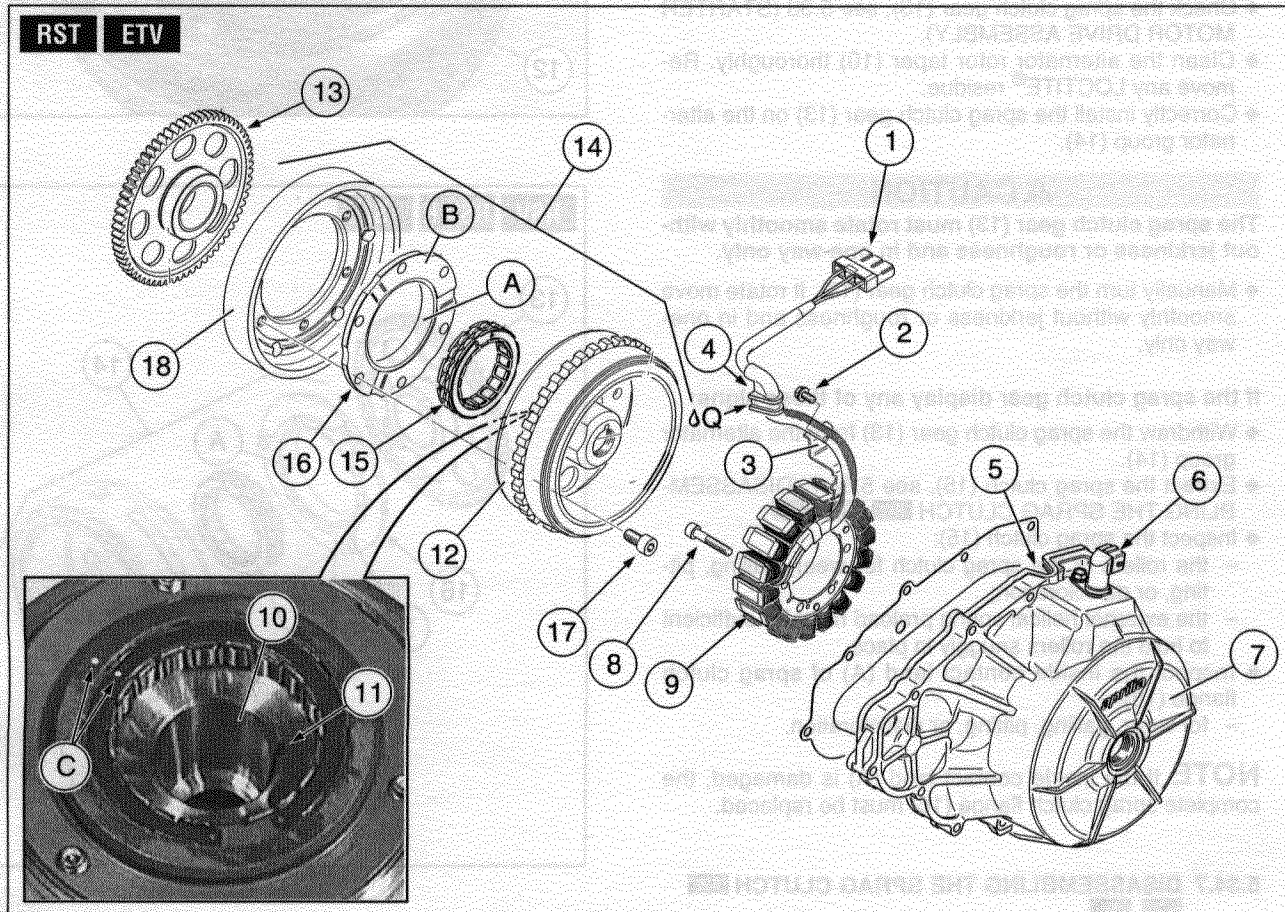

Key

- | | |
|--|---|
| 1) Alternator connector. | 12) Alternator rotor. |
| 2) # one screw of stator cable hanger. | 13) Sprag clutch gear. |
| 3) Stator cable hanger. | 14) Alternator rotor group. |
| 4) Rubber cable guide. | 15) Sprag clutch. |
| 5) Seat of rubber cable guide. | 16) Sprag clutch flange. |
| 6) Crankshaft position sensor. | 17) # three Allen screws of alternator rotor housing. |
| 7) Alternator cover. | 18) Alternator rotor housing. |
| 8) # three Allen screws of stator. | A) Inside contact land of sprag clutch flange. |
| 9) Stator. | B) Contact flat surface of sprag clutch flange with alternator rotor. |
| 10) Alternator rotor taper. | C) Reference dot (for correct reassembly). |
| 11) Key seat. | |

5.35.1 TO GAIN ACCESS TO THE ALTERNATOR RST ETV

- ◆ Remove the alternator cover (7) with:
 - stator (9);
 - crankshaft position sensor (6);
 see 4.8 (REMOVING THE ALTERNATOR COVER AND ALTERNATOR SYSTEM).

5.35.2 CHECKING THE STATOR  **CAUTION**

Do not force the electric cables.

- ◆ Measure the resistance between the three yellow cables of the alternator connector (1) using an ohmmeter.
- Standard resistance value in the range 0.1 – 1.0 Ω at 20 °C (68 °F).

NOTE If the resistance value does not fall within this range, the stator must be replaced.

5.35.3 DISASSEMBLING THE STATOR  

Stator cable hanger M6 screw (2) tightening torque: 8 ftlb (11 Nm).

- ◆ Unscrew and remove the M6 screw (2).
- ◆ Remove the stator cable hanger (3).
- ◆ Release the rubber cable guide (4) from its seat (5) of the alternator cover (7).

NOTE Do not remove the crankshaft position sensor (6) from the alternator cover (7).

Stator M6 Allen screws (8) tightening torque: 8 ftlb (11 Nm).

- ◆ Unscrew and remove the three M6 Allen screws (8) of the stator.
- ◆ Extract the stator (9) from the alternator cover seat.
- ◆ Check the sealing surface of the current alternator cover (7) for damage or warpage.

5.35.4 ASSEMBLING THE STATOR  

- ◆ Insert the stator (9) in the alternator cover seat.

NOTE Apply a couple of drops of LOCTITE® 243 to the threads of the stator M6 Allen screws (8).

- ◆ Install and tighten the three M6 Allen screws (8).

Stator M6 Allen screws (8) tightening torque: 8 ftlb (11 Nm).

NOTE Apply a layer of SILASTIC 732 RTV to the rubber cable guide (4).

- ◆ Insert the rubber cable guide (4) in its seat (5) of the alternator cover (7).
- ◆ Correctly place the stator cable hanger (3).

NOTE Apply a couple of drops of LOCTITE® 243 to the threads of the stator cable hanger M6 screw (2).

- ◆ Install and tighten the M6 screw (2).

Stator cable hanger M6 screw (2) tightening torque: 8 ftlb (11 Nm).

B = LOCTITE® 243.
Q = SILASTIC 732 RTV.

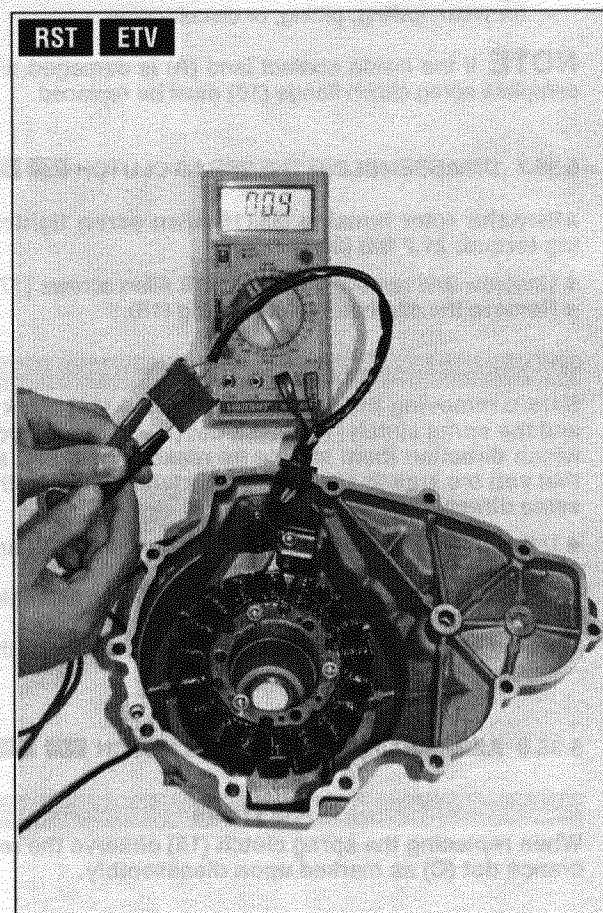
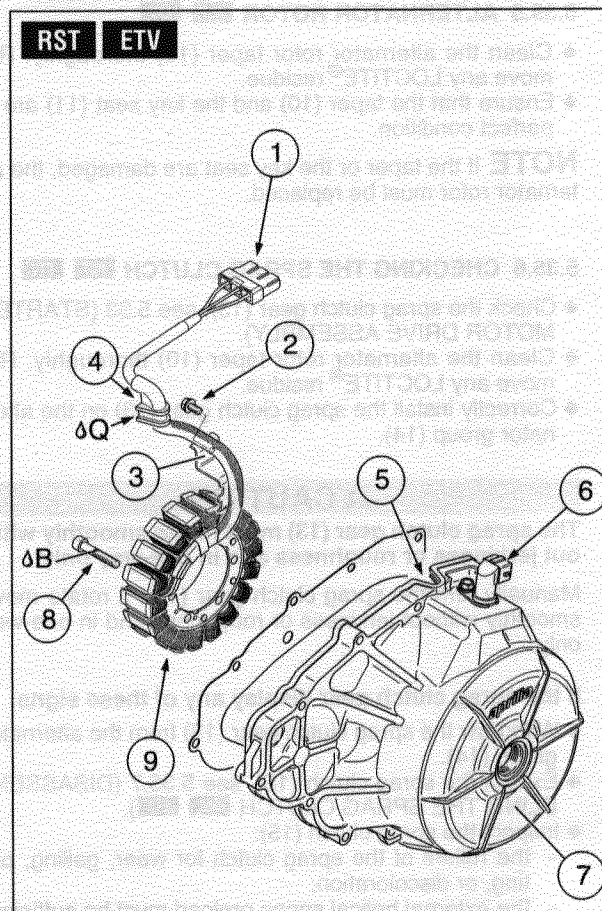

5.35.5 ALTERNATOR ROTOR RST ETV

- ◆ Clean the alternator rotor taper (10) thoroughly. Remove any LOCTITE® residue.
- ◆ Ensure that the taper (10) and the key seat (11) are in perfect condition.

NOTE If the taper or the key seat are damaged, the alternator rotor must be replaced.

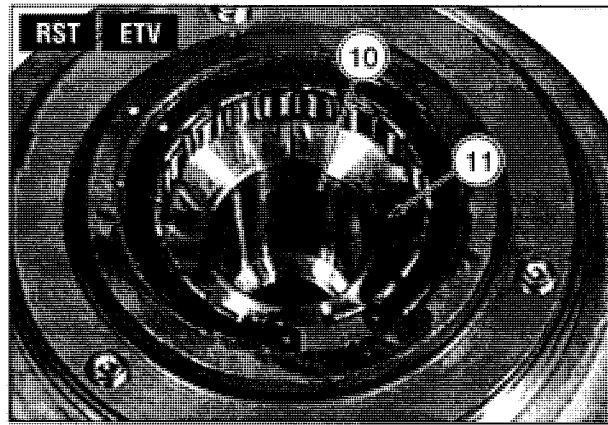

5.35.6 CHECKING THE SPRAG CLUTCH RST ETV

- ◆ Check the sprag clutch gear (13), see 5.33 (STARTER MOTOR DRIVE ASSEMBLY).
- ◆ Clean the alternator rotor taper (10) thoroughly. Remove any LOCTITE® residue.
- ◆ Correctly install the sprag clutch gear (13) on the alternator group (14).

CAUTION

The sprag clutch gear (13) must rotate smoothly without jerkiness or roughness and in one-way only.

Manually turn the sprag clutch gear (13), it rotate move smoothly without jerkiness or roughness and in one-way only.

If the sprag clutch gear display any of these signs:

- ◆ Withdraw the sprag clutch gear (13) from the alternator group (14).
- ◆ Extract the sprag clutch (15), see 5.35.7 (DISASSEMBLING THE SPRAG CLUTCH RST ETV).
- ◆ Inspect the sprag clutch (15):
 - the rollers of the sprag clutch for wear, galling, pitting, or discoloration;
 - the external helical spring preload must be sufficient to hold the rollers snugly in place.
- ◆ Inspect the inside contact land (A) of sprag clutch flange (16):
 - for wear, galling, pitting, or discoloration.

NOTE If the inside contact land (A) is damaged, the complete sprag clutch flange (16) must be replaced.

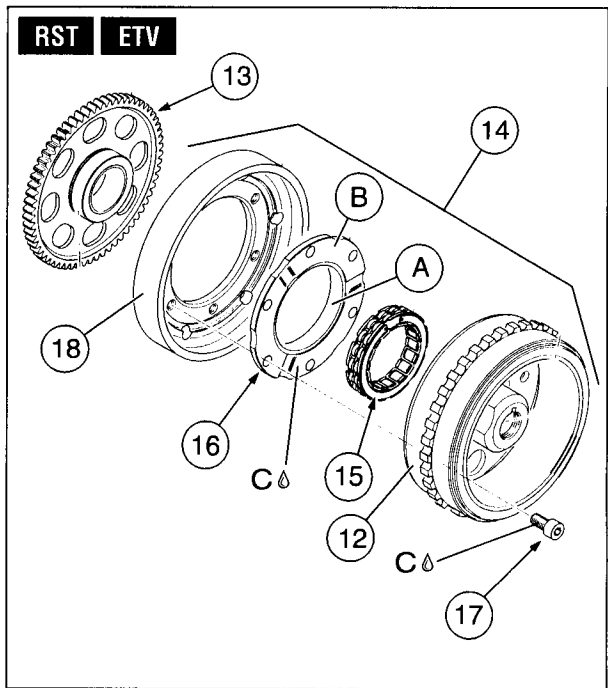

5.35.7 DISASSEMBLING THE SPRAG CLUTCH RST ETV

Alternator rotor housing M8x18 Allen screw tightening torque: 21.7 ftlb (30 Nm).

- ◆ Unscrew and remove the six M8x18 Allen screws (17).
- ◆ Remove the alternator rotor housing (18).

CAUTION

Before removing the sprag clutch flange (16) mark it and the sprag clutch (15) with a dot (C), to remind you which direction them should be reassembled and so that you are sure to refit the sprag clutch (15) with the same direction of rotation.

- ◆ Using a felt pen, mark the sprag clutch flange (16) and the sprag clutch (15) with a dot (C).
- ◆ Detach the sprag clutch flange (16) from the alternator rotor (12).
- ◆ Remove the sprag clutch (15) from its seat, on the sprag clutch flange (16).

5.35.8 ASSEMBLING THE SPRAG CLUTCH RST ETV

CAUTION

When replacing the sprag clutch (15) observe the reference dot (C) as marked upon disassembly.

- ◆ Correctly insert the sprag clutch (15) in its seat, on the sprag clutch flange (16). Refer to the reference dot (C) applied during disassembly.

CAUTION

Use LOCTITE® 648 on the contact flat surface (B), of the sprag clutch flange (16), with the alternator rotor.

- ◆ Apply a couple of drops of LOCTITE® 648 to the contact flat surface (B) of the sprag clutch flange (16) and correctly place it in the center of the alternator rotor (12).
- ◆ Correctly place the alternator rotor housing (18) on the alternator rotor (12).

CAUTION

Use LOCTITE® 648 on the six M8x18 Allen screws (17) of the alternator rotor housing (17).

- ◆ Apply couple of drops of LOCTITE® 648 to the threads of the M8x18 Allen screws (17).
- ◆ Screw in and tighten the six M8x18 Allen screws (17).

Alternator rotor housing M8x18 Allen screw tightening torque: 21.7 ftlb (30 Nm).

C = LOCTITE® 648.

5.36 SPARK PLUGS

Consult the section 2 (SERVICE AND SETTING UP) of specific vehicle workshop manual see 0.4.1 (VEHICLE WORKSHOP MANUAL).

5.37 COUNTERSHAFT SPROCKET

Carefully read 5.1 (PREFACE).

- ◆ Check the sprocket's internal spline (1) for wear.

NOTE If the teeth is worn, change the countershaft sprocket and check the teeth of the countershaft.

- ◆ Check the sprocket's external teeth (2) for wear and distortion.

NOTE If the teeth of the countershaft sprocket are worn or distorted, the countershaft sprocket, rear sprocket and chain must be replaced as a set.

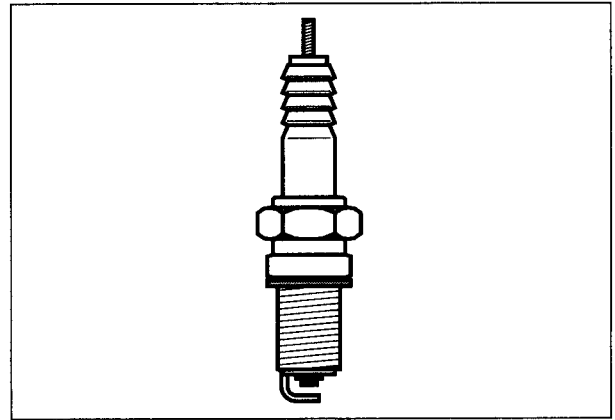
**5.38 STARTER MOTOR**

Carefully read 5.1 (PREFACE).

- ◆ Remove the starter motor, see 4.5 (REMOVING THE STARTER MOTOR).

NOTE The starter motor does not normally wear out, and has a very long life. If the carbon brushes are worn, they may be replaced using the available repair kit. This is the only repair authorized for this component. Any other damage or defect requires that the complete starter motor be replaced.

- ◆ Check the starter motor pinion (3) for pitting, distortion or discoloration. If it is damaged, replace the complete starter motor.
- ◆ Check the starter motor mount O-ring (4) for any signs of damage. It is advisable to replace this O-ring any time a starter motor is removed.
- ◆ Unscrew and remove the two M6 screws (5) and remove the complete rear cover (6).
- ◆ Check the four carbon brushes for freedom of movement in their holders. If they are stuck and cannot be freed, the starter motor must be repaired or replaced.
- ◆ Check the preloading of the brush springs.
- ◆ Check the length of the carbon brushes.

Wear limit min. 0.31 in (8.0 mm).

NOTE A kit is available which contains a rear cover complete with carbon brushes and seals.

- ◆ Replace the complete rear cover (6), install and tighten the two M6 screws (6).

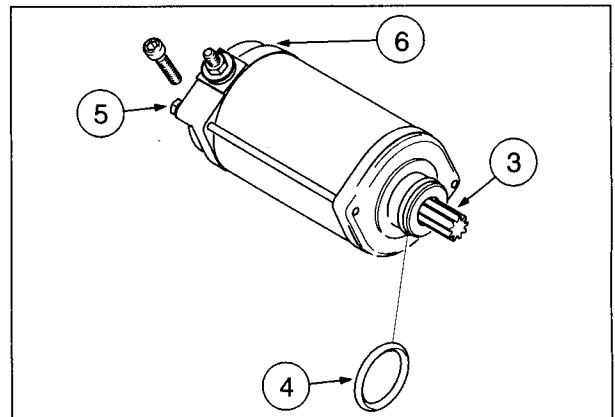
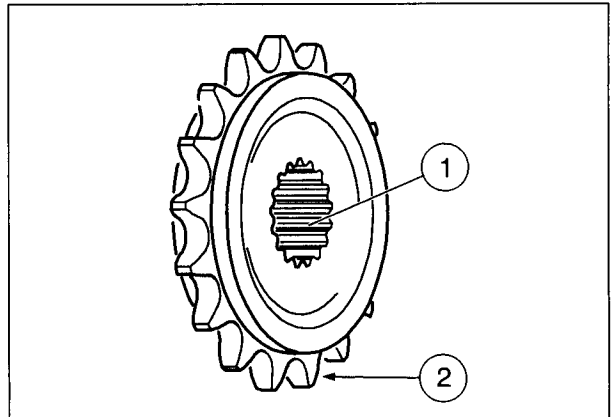

NOTE

Lined area for notes, containing a diagonal watermark: "THIS PAGE HAS BEEN INTENTIONALLY LEFT EMPTY"

REASSEMBLING THE ENGINE

6

REASSEMBLING THE ENGINE

TABLE OF CONTENTS

6.1 PREFACE	6-3-00
6.2 ENGINE REASSEMBLY SEQUENCE	6-3-00
6.3 ENGINE CHECKS SUBSEQUENT TO REASSEMBLY	6-3-00
6.4 ASSEMBLING THE GEARBOX	6-3-00
6.5 ASSEMBLING THE CRANKSHAFT AND LOWER BALANCESHAFT	6-4-00
6.6 ASSEMBLING THE ENGINE CASES	6-5-00
6.7 ASSEMBLING THE GEAR SELECTION MECHANISM	6-6-00
6.8 CHECKING THE GEAR SELECTION MECHANISM	6-7-00
6.9 ASSEMBLING THE OIL PUMP	6-8-00
6.10 ASSEMBLING THE CAM OPERATING MECHANISM FOR THE REAR CYLINDER (CYLINDER "2") ...	6-9-00
6.11 ASSEMBLING THE COOLANT PUMP DRIVE	6-11-00
6.12 ASSEMBLING THE PRIMARY DRIVE AND CLUTCH	6-12-00
6.13 ASSEMBLING THE PISTON AND CYLINDER "2" (REAR)	6-14-00
6.14 ADJUSTING VALVE CLEARANCE	6-17-00
6.15 ASSEMBLING HEAD "2" (REAR) CAMSHAFT	6-18-00
6.16 ASSEMBLING HEAD "2" (REAR) TIMING DRIVE ASSEMBLY	6-19-00
6.17 ASSEMBLING HEAD "1" (FRONT) TIMING DRIVE ASSEMBLY	6-21-00
6.18 ASSEMBLING THE STARTER MOTOR DRIVE ASSEMBLY AND ALTERNATOR	6-23-00
6.19 ASSEMBLING THE PISTON AND CYLINDER "1" (FRONT)	6-24-00
6.20 ASSEMBLING HEAD "1" (FRONT) CAMSHAFT	6-27-00
6.21 ASSEMBLING HEAD "1" (FRONT) TIMING DRIVE ASSEMBLY	6-28-00
6.22 ASSEMBLING THE VALVE COVER	6-29-00
6.23 ASSEMBLING THE ALTERNATOR COVER	6-30-00
6.24 ASSEMBLING THE CLUTCH HOUSING	6-31-00
6.25 ASSEMBLING THE STARTER MOTOR	6-32-00
6.26 ASSEMBLING THE ENGINE OIL FILTER	6-32-00

6.1 PREFACE

This section contains the information and data required by the professional mechanic to reassemble the engine.

Carefully read 4.2 (IMPORTANT INFORMATION).

⚠ WARNING

Touching the engine while hot may cause burns.

⚠ CAUTION

When reassembling the engine, always replace all gaskets, circlips, O-rings and seals.

Unless otherwise instructed, lubricate all moving and sliding parts with engine oil as the engine is reassembled.

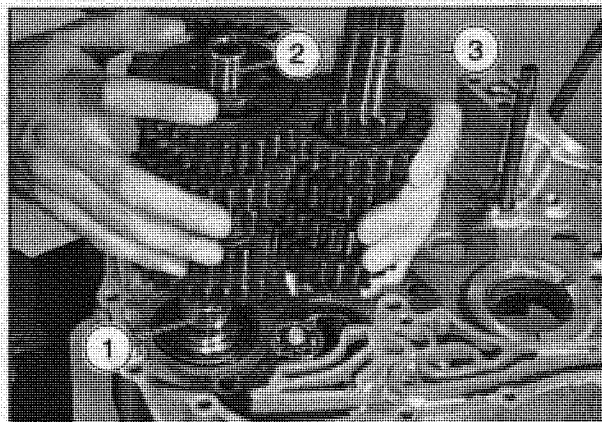

6.2 ENGINE REASSEMBLY SEQUENCE

⚠ CAUTION

Any components removed must be set aside in groups arranged according to their assembly position. This will ensure that when you reassemble the engine, all parts will be fitted in their proper locations.

NOTE Before going ahead with the reassembly of the engine, gather the appropriate special tools, see 2.7 (SPECIAL TOOLS **OPT**).

NOTE For the engine reassembly sequence, see 4.4 (ENGINE DISASSEMBLY SEQUENCE), following the diagram sequence in reverse order.

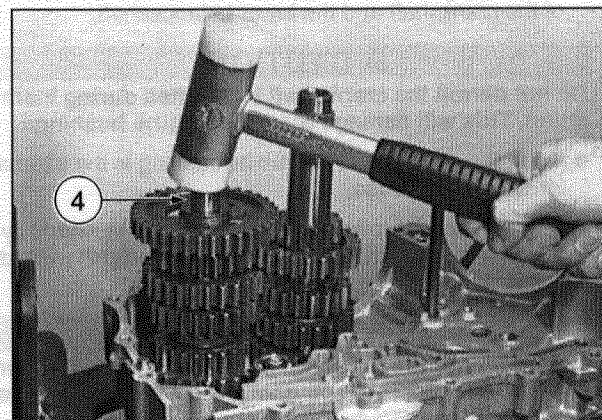

6.3 ENGINE CHECKS SUBSEQUENT TO REASSEMBLY

Consult the corresponding chapter in the section 3 (ENGINE) of specific vehicle workshop manual, see 0.4.1 (VEHICLE WORKSHOP MANUAL).

6.4 ASSEMBLING THE GEARBOX

Carefully read 6.1 (PREFACE).

NOTE Assemble the gears on the driving shafts, see 5.14 (GEARBOX).

NOTE Have the appropriate special tool **OPT** available:
– aprilia part# 0277308 (countershaft guide bushing) (1).

- ◆ Insert the guide bushing (1) into the gear of the countershaft (2).
- ◆ Fill the space between the two lips of the secondary shaft wheel with grease.
- ◆ Apply a thin coat of LOCTITE® Anti Seize to the areas of the countershaft (2) and main shaft (3), where they are inserted into the bearings.
- ◆ Insert the main shaft (3) into its bore on the alternator side half of the engine case.
- ◆ Insert the countershaft (2) into its bore on the alternator side half of the engine case.
- ◆ Insert the complete gear assembly into the case, tapping the two shafts lightly until they are driven completely home.

NOTE Proceed with caution. Do not force the gears into place. If properly assembled, they will easily tap into place.

- ◆ Install the washer (4) on the countershaft (2).
- ◆ Coat the forks of the fifth and sixth gear (5) with engine oil and insert them into the appropriate selector gear slots on the main shaft (3).
- ◆ Coat the fork of the second and fourth gear (6) and the first and third gear fork (7) with engine oil, and install them into their respective selector gear grooves on the countershaft (2).

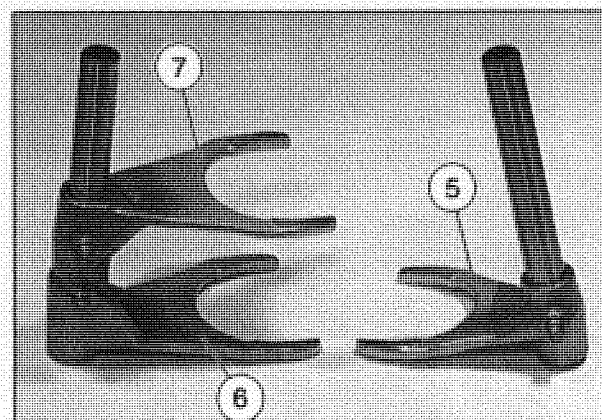
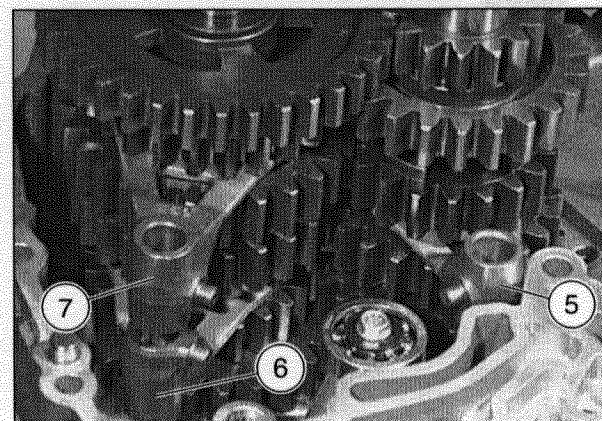

Follow ►

Follow ►

- ◆ Apply a little oil to the shift cam (8) and insert it into its appropriate bearing in the case.
- ◆ Ensure that the three gearshift fork pegs are properly aligned and installed in the appropriate slots in the gearshift cam (8).
- ◆ Insert the two gearshift shafts (9), pushing them all the way home into their respective holes in the alternator side half engine case.

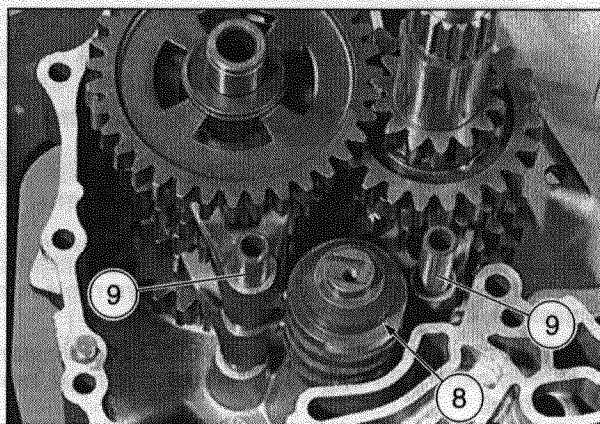

6.5 ASSEMBLING THE CRANKSHAFT AND LOWER BALANCESHAFT

Carefully read 6.1 (PREFACE).

- ◆ Apply a coat of MOLYKOTE® G-N on the bearing lands of the crankshaft and the lower balancershaft.

⚠ CAUTION

Do not permit the crankshaft to be tilted during installation. This will damage the main engine bushings.

- ◆ Insert the crankshaft (10) into its bushing in the alternator side engine case.

NOTE Place the lower connecting rod (11) towards cylinder "2" (rear) and the upper connecting rod (12) towards cylinder "1" (front).

⚠ CAUTION

Do not permit the lower balancershaft to be tilted during installation. This will damage the lower balancershaft bushings.

- ◆ Insert the lower balancershaft (13) into its appropriate bushing.

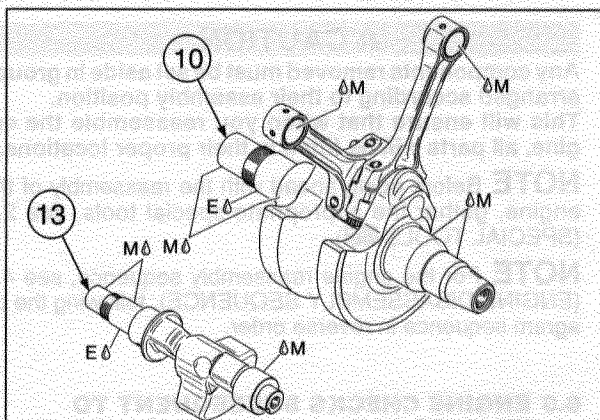

M = MOLYKOTE® G-N.
E = LOCTITE® Anti Seize 15378.

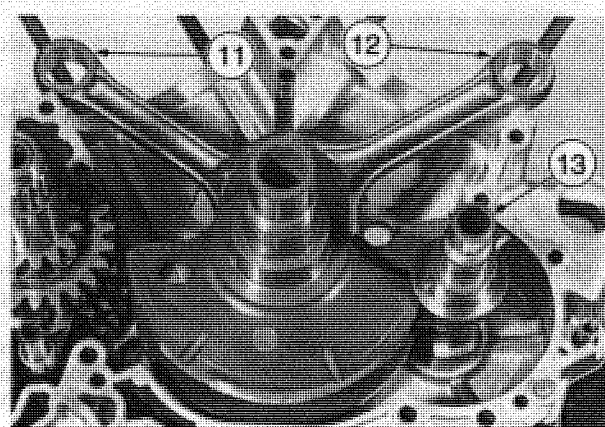
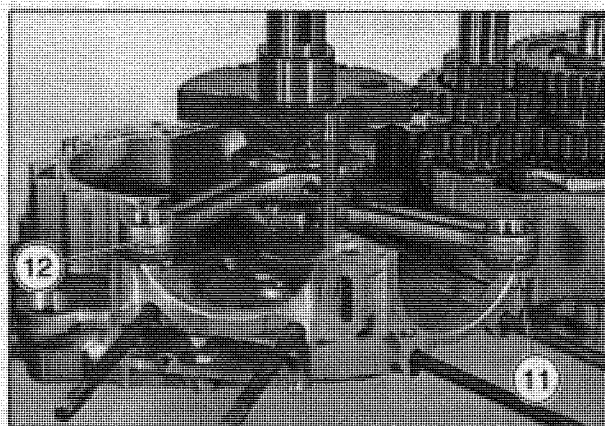

6.6 ASSEMBLING THE ENGINE CASES

Carefully read 6.1 (PREFACE).

CAUTION

Never reuse an used engine case gasket. Use only new, original equipment **aprilia** engine case gasket.

- ◆ Place the engine case gasket (1) on the alternator side half of the engine case.

NOTE The gasket must line up with all engine case holes. You may apply grease to the gasket to hold it in place. Be very careful to ensure that the gasket does not move out of position as you assemble the cases.

- ◆ Ensure that the washer (2) is properly placed on the countershaft (3).
- ◆ Apply **LOCTITE**® Anti Seize to the countershaft (3) and to main shaft (4).
- ◆ Apply **MOLYKOTE**® G-N to the crankshaft (5) and lower balancershaft (6).
- ◆ Ensure that the oil spray pipe (7) is fitted.
- ◆ Ensure that the oil screen is inserted in the clutch side half of the engine case.
- ◆ Assemble the cases by installing the clutch side half of the engine case over all of the shafts on the alternator side.

NOTE If necessary, use a plastic mallet to lightly tap on the case ribs only near the shafts. Be extremely careful not to damage the gasket surface of the clutch cover (9).

- ◆ Rotate the engine case to 90° as shown in the illustration (A).

NOTE Work from the alternator side.

CAUTION

Apply torque to the screws in a criss-cross pattern, tightening each screw only slightly and evenly, until all the screws are properly torqued.

- ◆ Install the twenty M6 Allen screws into the engine case:
 - thirteen M6x65 screws (10);
 - five M6x45 screws (11);
 - one M6x80 screw (12);
 - one M6x25 screw (13).

CAUTION

Ensure that you have installed each screw in its appropriate location. Failure to do this can do irreparable damage to the engine.

Screws tightening torque: 8 ftlb (11 Nm).

NOTE After you have tightened all of the screws, and ensure that they are evenly and properly torqued, turn the crankshaft, lower balancershaft, and main shaft and countershaft with your fingers. They should be able to move, at least a little distance, without noticeable resistance.

- ◆ Check the end play of the crankshaft using a dial gauge.

Wear limit: max. 0.02 in (0.5 mm).

NOTE Cover the engine compartment with a clean cloth.

- ◆ Using a razor blade or sharp hobby knife, cut away the parts of the gaskets protruding from the engine case around the cylinder flange.

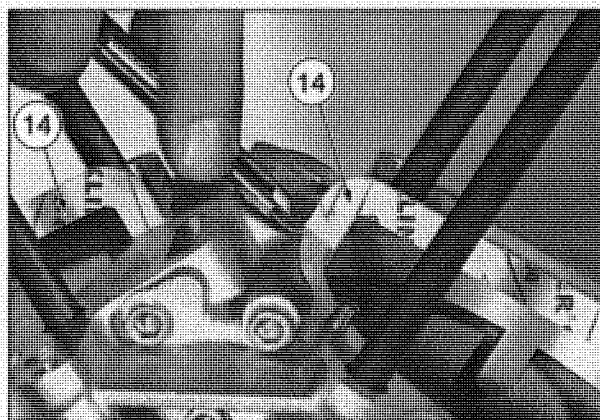
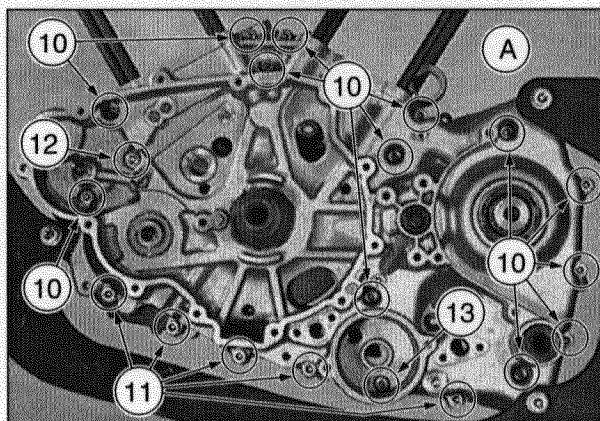
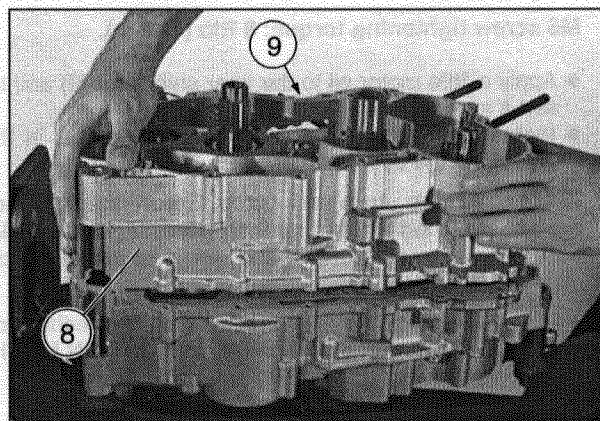
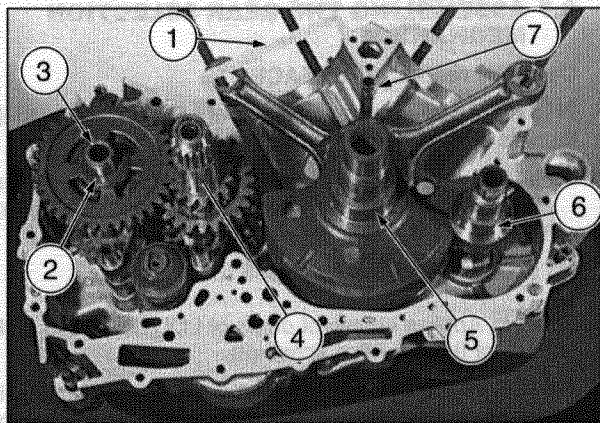

6.7 ASSEMBLING THE GEAR SELECTION MECHANISM

Carefully read 6.1 (PREFACE).

NOTE Apply a couple of drops of LOCTITE® 243 to the threads of the M6 Allen screw (5).

- ◆ Fit the index spring (1), spacer (2), index lever (3) and washer (4) and secure them with the M6 Allen screw (5).

M6 screw tightening torque: 8 ftlb (11 Nm).

NOTE Apply a couple of drops of LOCTITE® 243 to the threads of the M6 Allen screw (8).

- ◆ Press the index lever (3) down with your finger and insert the index plate (6) in the slot in the end of the shift cam (7), fastening it in place with the M6 Allen screw (8).

M6 screw tightening torque: 8 ftlb (11 Nm).

- ◆ Apply a little motor oil to the gear shift shaft (9) and insert it into its bore.
- ◆ Install the thrust washer (10) and circlip (11) in the groove on the countershaft.

NOTE Always use a new circlip. Ensure that the ends are not stretched any farther than necessary for installation. Use the appropriate special pliers to install the circlip.

- ◆ Check the efficiency of the gear selection mechanism, see 6.8 (CHECKING THE GEAR SELECTION MECHANISM).

B = LOCTITE® 243.

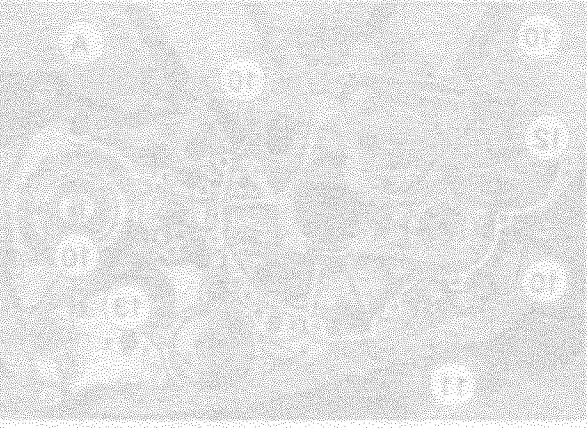
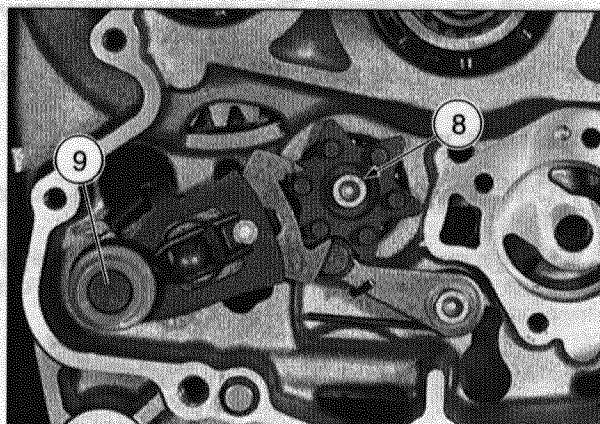
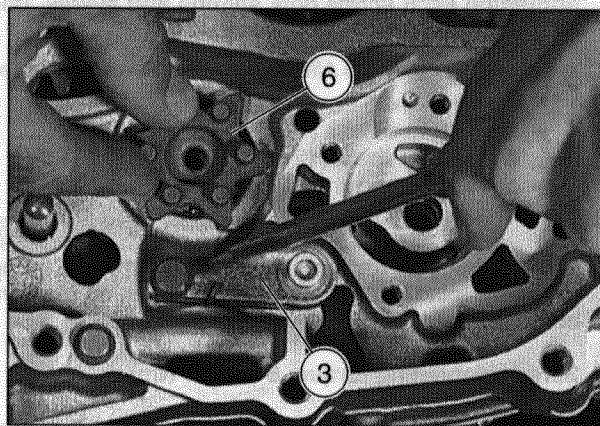
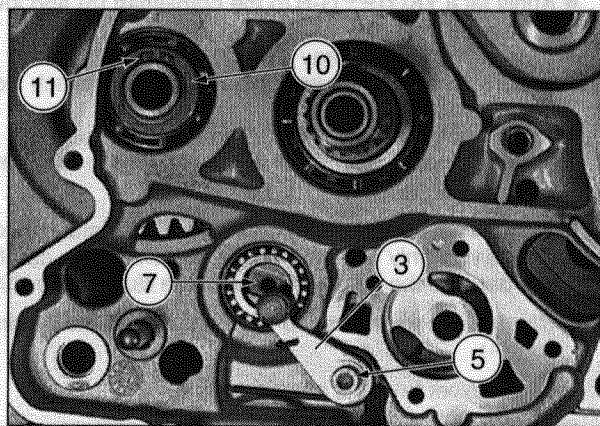
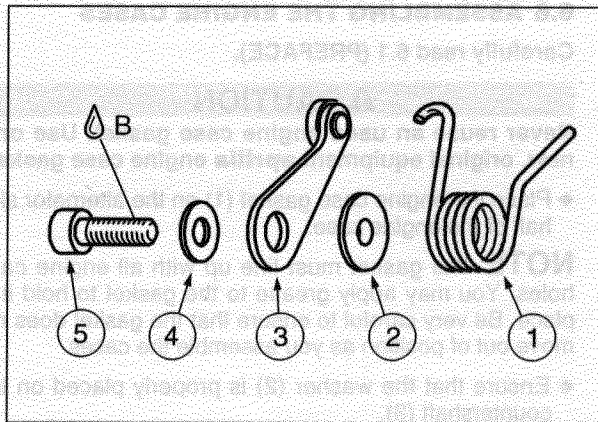

6.8 CHECKING THE GEAR SELECTION MECHANISM

Carefully read 6.1 (PREFACE).

- ◆ Ensure that the hair pin spring (1) in the rotating lever (2) and the cylindrical pin (3) fit tightly together. There should be no clearance between the lever or the pin and the arms of the spring.

NOTE If necessary, the arms of the hair pin spring (1) may be slightly bent to achieve this.

- ◆ Engage, one by one, all of the gears. Ensure that the pins (4) on the index plate (5) are centered between the pawls of the ratchet.

NOTE Again, if it is necessary to bend the end of the hair pin spring slightly to center the pawls, this is permissible.

- ◆ Check the strength of the index spring (6). It must be held very firmly against the shift cam index plate.

NOTE Rotation of the shift cam must cause the index spring (6) to push the index lever (7) into the appropriate slot on the index plate (5) firmly.

- ◆ Put the gear shift into neutral. With your fingers, turn both shafts and all gears. Ensure that all gears and shafts turn freely.

▲ WARNING

Keep your fingers well away from the gears! You will be seriously injured if your fingers are caught between the gears.

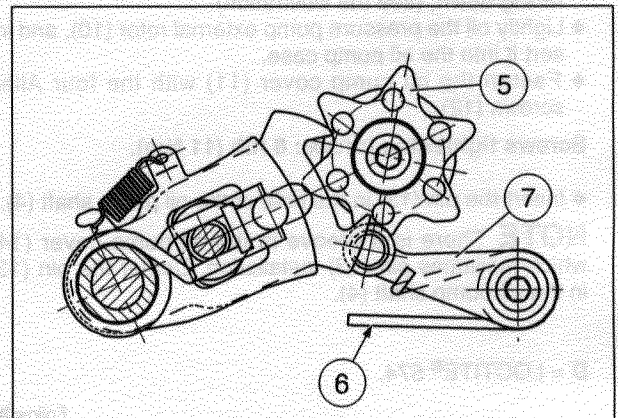
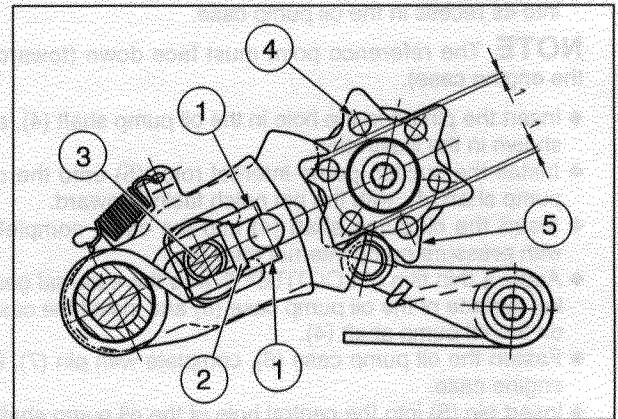
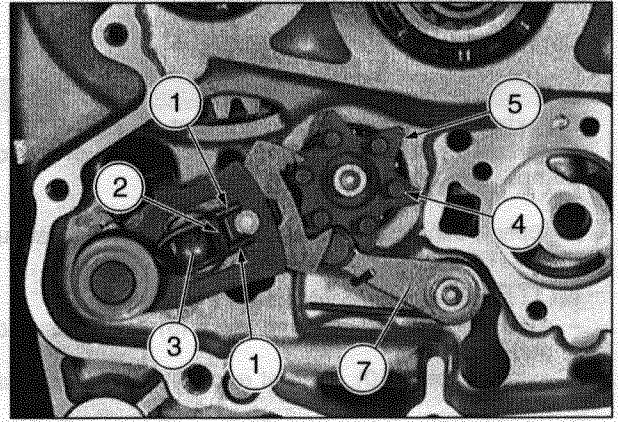

6.9 ASSEMBLING THE OIL PUMP

Carefully read 6.1 (PREFACE).

CAUTION

Be extremely careful to ensure that no **LOCTITE®** is allowed to enter any of the oil passages of the oil pump.

◆ Apply a thin film of **LOCTITE®** 574 on the gasket surface (1) of the oil pump case.

NOTE Store to keep separately the groups:

- external rotor (2), internal rotor (5) (of the suction pump);
- external rotor (10), internal rotor (9) (of the pressure pump).

Do not mix-up the components of these groups.

◆ Apply a little engine oil to the external oil rotor. Insert it into its recess in the oil pump case.

NOTE The reference point must face down (towards the engine case).

- ◆ Insert the pin (3) in the hole in the oil pump shaft (4), as shown in the illustration.
- ◆ Install the suction pump internal rotor (5) onto the oil pump shaft (4), with the pin notch facing upward.
- ◆ Insert the oil pump shaft (4) into the case, complete with pressure pump internal rotor (9).
- ◆ Apply a thin film of **LOCTITE®** 574 to the external gasket surface of the oil pump case (6) and install the case on the oil pump shaft (4).
- ◆ Fasten the oil pump case (6), complete with pin (7), to engine case.
- ◆ Insert pin (8) into the central hole of the oil pump shaft.
- ◆ Lightly oil the pressure pump internal rotor (9) and install it on the oil pump shaft with the drive pin groove facing down, (see the illustration).
- ◆ Lightly oil the pressure pump external rotor (10), and insert it into the oil pump case.
- ◆ Fasten the oil pump cover (11) with the four Allen screws (12).

Screws tightening torque: 8 ftlb (11 Nm).

◆ Insert the pin (13) in the hole of the oil pump shaft (4).

NOTE There is a groove in the oil pump cover (14) which facilitates pin (13) installation. Center the pin (13) in the oil pump shaft (4).

D = **LOCTITE®** 574.

Follow ►

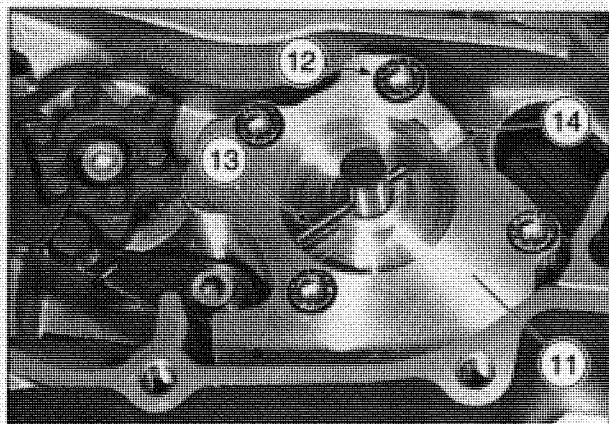
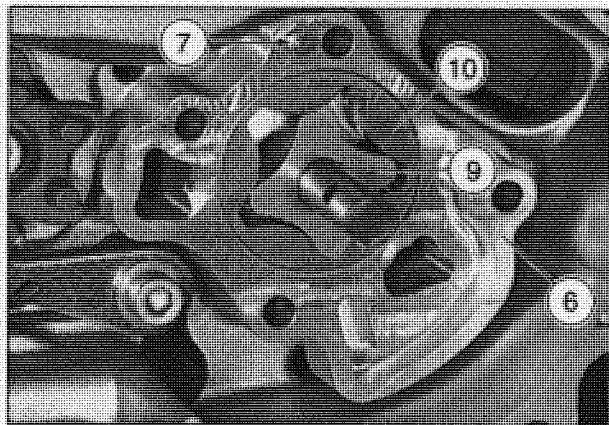
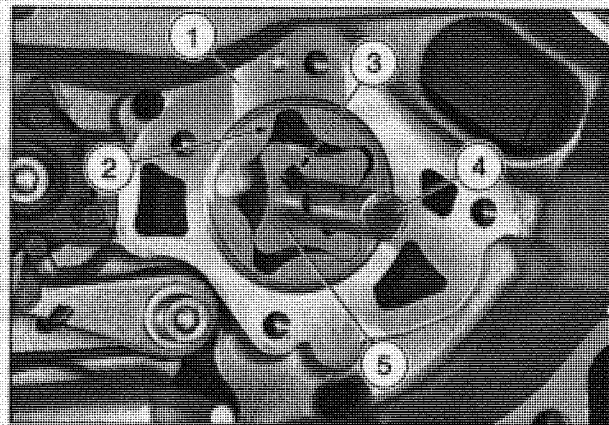
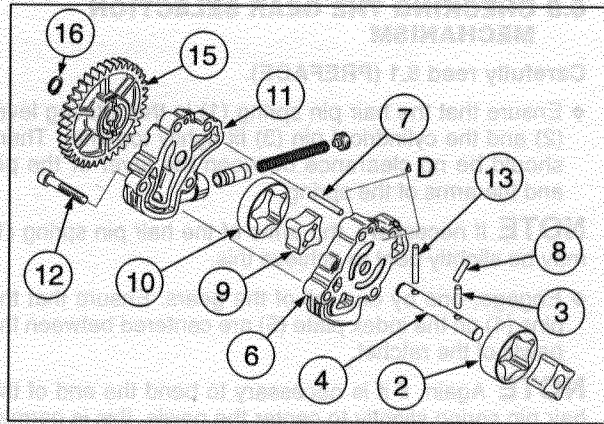

Follow ►

CAUTION

Once disassembled, the oil pump gear must always be replaced.

- ◆ Fit a new oil pump gear (15).

NOTE You must feel the pin (13) engaging perfectly inside the groove on the oil pump gear.

- ◆ Fit the circlip (16) in its groove on the oil pump shaft.

NOTE Ensure that the circlip is inserted all the way into the groove.

Ensure that the ends are not pulled any farther apart than necessary.

- ◆ Check the rotation and end play of the oil pump shaft (4).

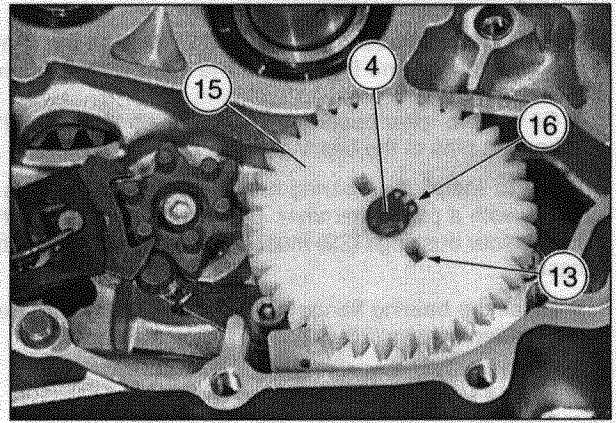

6.10 ASSEMBLING THE CAM OPERATING MECHANISM FOR THE REAR CYLINDER (CYLINDER "2")

Carefully read 6.1 (PREFACE).

- ◆ Turn the crankshaft so that the connecting rod of cylinder "2" is at Top Dead Center (TDC).

NOTE Have the appropriate special tool  available:

- **aprilia** part# 0240880 (threaded bolt for retaining the crankshaft at TDC) (17);

- ◆ Lock the crankshaft in place with the threaded bolt (17).

NOTE When cylinder "2" is at TDC, the locking slot (18) of cylinder "1" is visible through the gap under the lower balancershaft.

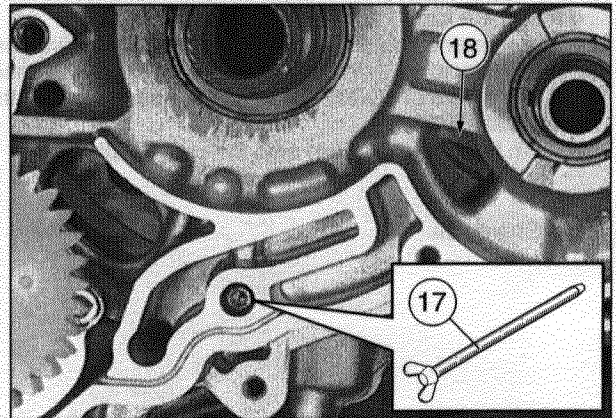

The threaded bolt (17) must never be overtightened.

Threaded bolt tightening torque: max. 3.6 ftlb (5 Nm).

- ◆ Apply a coat of grease to the thrust washer (19). Place it on the intermediate drive gear (20).

NOTE Install the timing chain (21) in its appropriate position. Refer to the reference marks applied during disassembly.

- ◆ Place the timing chain (21) around the intermediate drive gear (20), guiding both through the chain compartment and inserting them in the case.

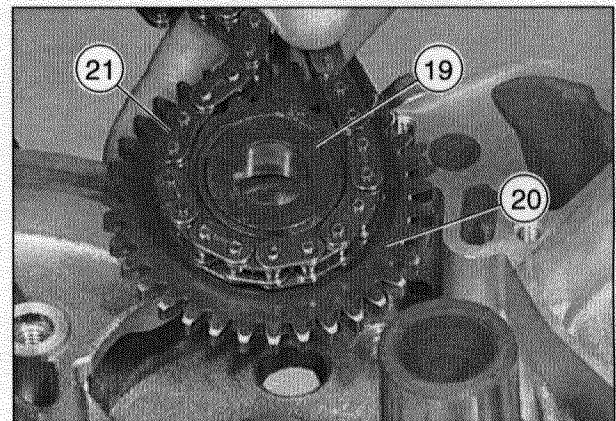

N = Multi-purpose grease bp lz.

Follow ►

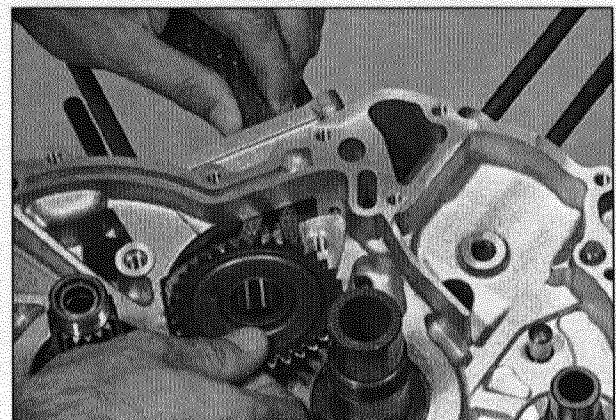
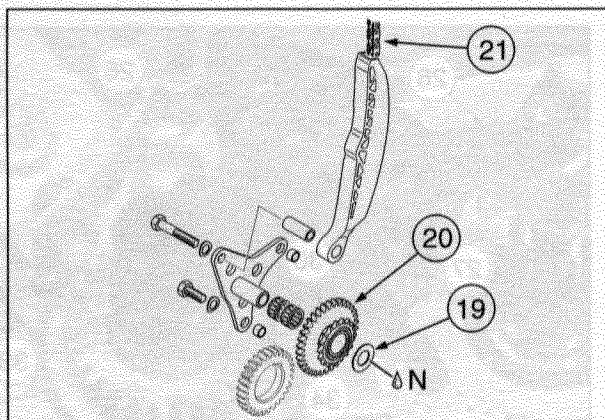

Follow ►

- ◆ Guide the chain tensioner shoe (22) through the chain compartment and fasten it to the case with a spacer bushing (23).
- ◆ Oil the two roller bearings (24) and push them into the bearing pins of the bearing flange (25).

NOTE Install the bearing flange fully home, tapping it gently with a plastic hammer. Before this is possible, the two spacer bushings (29) must be fastened to the engine case.

- ◆ Install the bearing flange (25), fasten it using the three M8 Allen screws (26) (27) and spring washers (28):
 - two M8x45 screws (26);
 - one M8x20 screw (27).

Screws tightening torque: 18 ftlb (25 Nm).

- ◆ Check the rotation of the intermediate drive gear.
- ◆ Install the key (30) in the crankshaft taper.
- ◆ The reference mark (31) on the intermediate drive gear must coincide with the reference mark (32) on the case.
- ◆ Apply a coat of LOCTITE® Anti Seize on the end of the crankshaft (33).
- ◆ Push the drive gear (34) onto the crankshaft.

 = Engine oil.

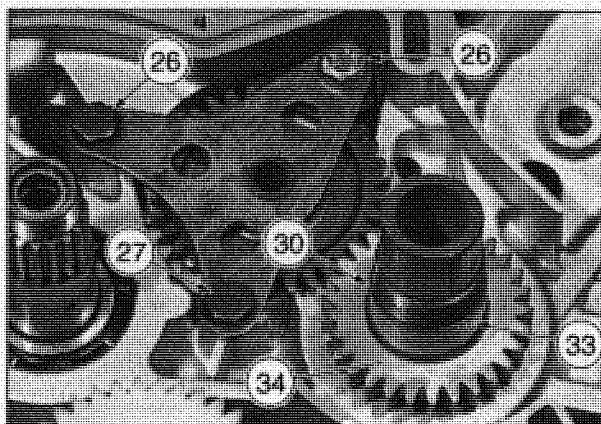
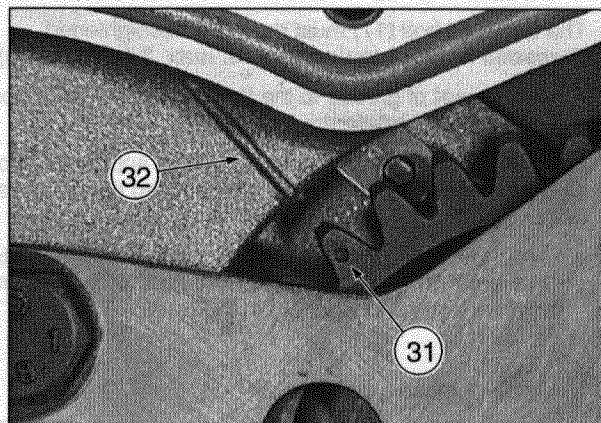
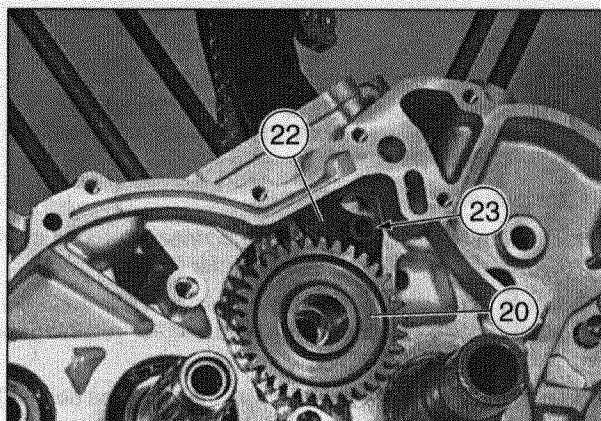
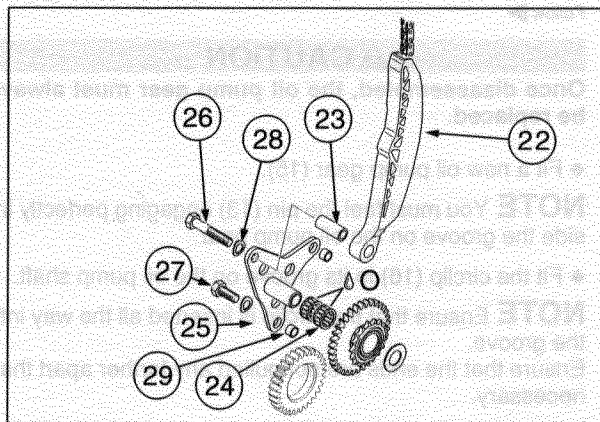

6.11 ASSEMBLING THE COOLANT PUMP DRIVE

Carefully read 6.1 (PREFACE).

- ◆ Coat the end of the lower balancshaft (1) with LOCTITE® Anti Seize.
- ◆ Apply engine oil to the bearing land at the end of the lower balancshaft.
- ◆ Install the key (2) in its seat on the lower balancshaft.
- ◆ Install the washer (3) on the lower balancshaft with its flared side facing down.
- ◆ Install the coolant pump gear (4) on the lower balancshaft.
- ◆ Install the coolant pump idler gear (5) on its pin.
- ◆ Install the washer (6) on the lower balancshaft.
- ◆ Install the main drive gear (7) on the crankshaft.

NOTE The reference point must be visible.

- ◆ Install the gear (8) on the lower balancshaft.

NOTE The reference point must be visible and must coincide with the reference mark on the main drive gear.

- ◆ Lift the lower balancshaft all the way in the axial direction and install the balancweight (9) on the lower balancshaft.

NOTE The key seat (10) in the balancweight (9) must engage the end of the weight (2).

- ◆ Install the spring washer (11) and tighten the M22x1.5 nut (12).

M22x1.5 nut tightening torque: 108 ftlb (150 Nm).

NOTE Ensure that the position of the hole for the counterweight (9) is at approximately 10:00.

- ◆ Check the end play of the lower balancshaft with a dial gauge:

Wear limit: max. 0.012 in (0.3 mm).

O = Engine oil.
E = LOCTITE® Anti Seize 15378.

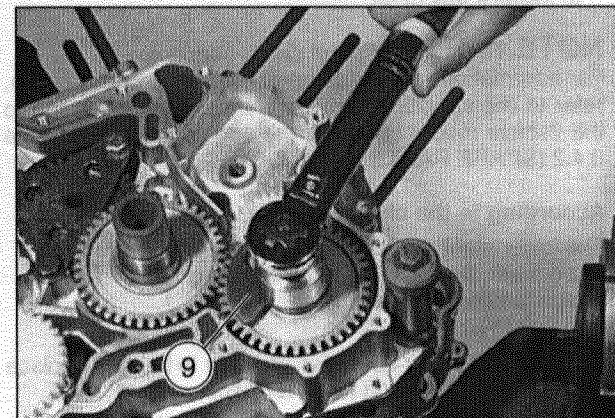
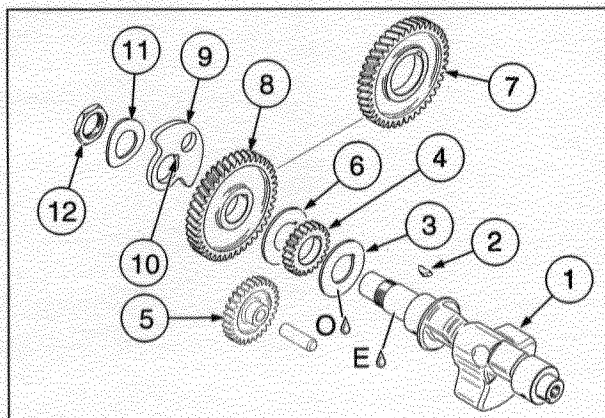
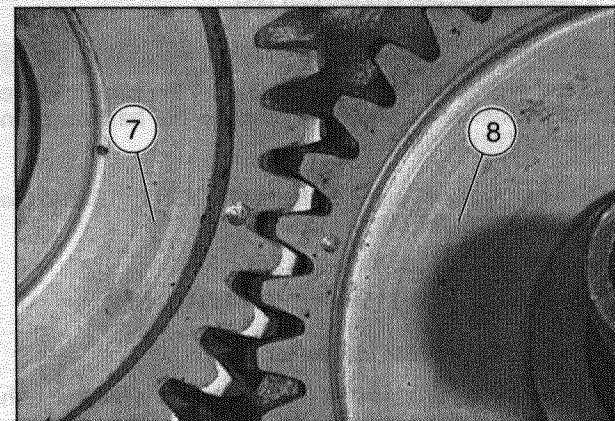
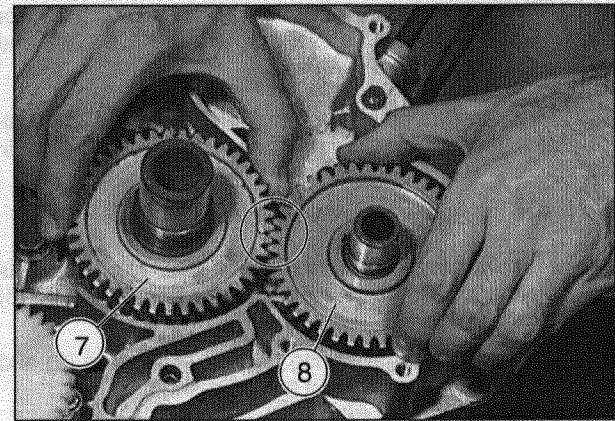
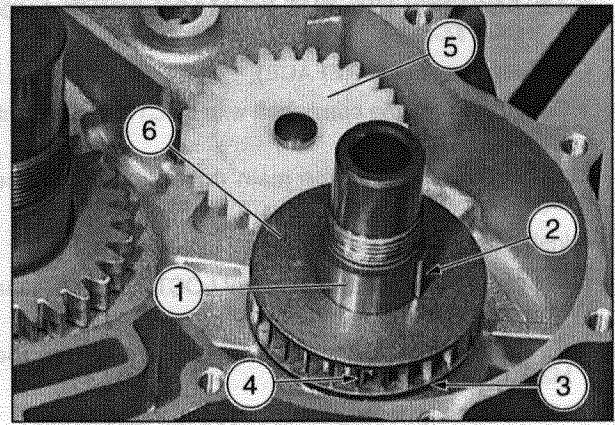

6.12 ASSEMBLING THE PRIMARY DRIVE AND CLUTCH

Carefully read 6.1 (PREFACE).

- ◆ Coat the end of the crankshaft with LOCTITE® 767 Anti Seize.

NOTE The collar of the main drive gear must face down.

- ◆ Install the main drive gear (1) on the crankshaft.

NOTE Apply a couple of drops of LOCTITE® 243 to the threads of the M33x1.5 nut (2).

- ◆ Fit the spring washer, then fasten and tighten the M33x1.5 nut (2).

M33x1.5 nut tightening torque: 166 ftlb (230 Nm).

- ◆ Preassembly the primary drive, see 5.19.1 (PRIMARY DRIVE aprilia part# 0295790 – PREASSEMBLY) or 5.19.2 (PRIMARY DRIVE aprilia part# 0295792 and 0295793 – PREASSEMBLY).

NOTE Apply a couple of drops of LOCTITE® 767 Anti-Seize to the bearing land (3) and to the spline (4) of main shaft.

- ◆ Install the primary drive on the main shaft.

NOTE Rotate the oil pump driven gear (5), so that its teeth engages with the teeth of the oil pump drive gear (6) of the primary drive.

- ◆ Fit the serrated thrust ring (8), the clutch hub (9) and the spring washer (10) on the main shaft.

NOTE Have the appropriate special tool **OPT** available:
– aprilia part# 0277881 (clutch locking tool) (11).

- ◆ Insert the clutch locking tool (11).

CAUTION

Insert the clutch locking tool (11) all the way in to the clutch basket so as not to damage the basket when the nut (12) is tightened.

NOTE Apply a couple of drops of LOCTITE® 648 to the threads of the nut (12).

- ◆ Install and tighten the nut (12).

Nut (12) tightening torque: 123 ftlb (170 Nm).

- ◆ Remove the clutch locking tool (11).

NOTE The top lined disc (Z) is unique. It is marked with a blue dot. It must be installed last, in its original position.

- ◆ Locate the top lined disc (Z) and keep it apart, in order to install it last of all.

NOTE There are different clutch versions. For information regarding the components of the clutch, refer to the specific spare parts catalogue, according to the vehicle model on which the engine is installed, see 0.4.2 (SPARE PARTS CATALOGUE).

According to the clutch version.

The lower steel disc can be identified:

- no mark, the disc is exactly like the others;
- space between teeth (X);
- notch (Y).

- ◆ Identify the lower steel disc, in order to be able to place it first when installing the steel discs.

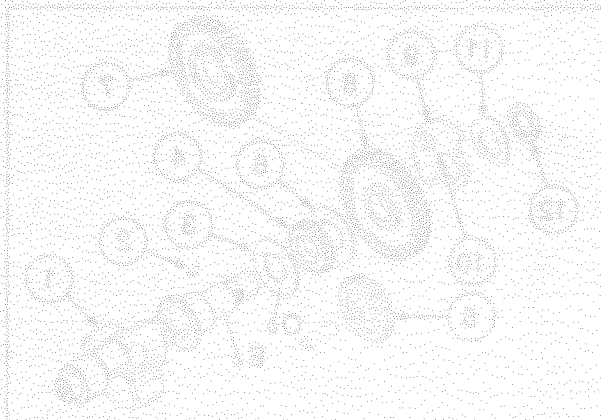
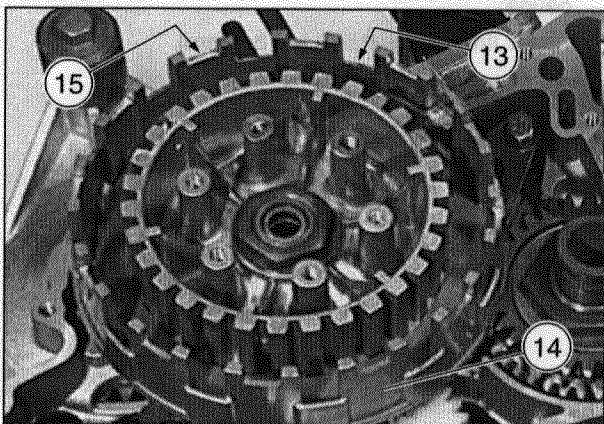
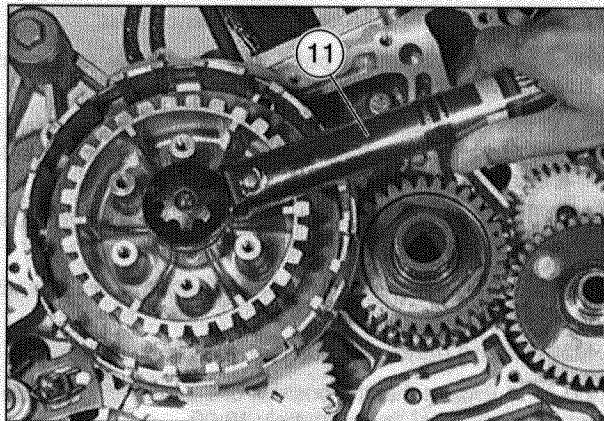
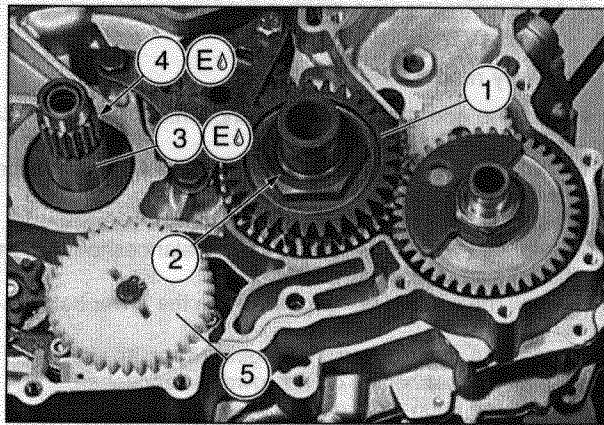

Follow ►

Follow ▶

NOTE The lined discs must be inserted in the grooves (13) in the clutch housing (14) except for the top lined disc which must be inserted in the offset grooves (15). The first disc installed is the steel disc (16), followed by a lined disc (17), then another steel disc (16), etc., alternately, until all the discs are installed.

- ◆ Install a steel disc (16) and a lined disc (17), alternately.
- ◆ Insert the top lined disc (Z) in the offset grooves (15).

NOTE Ensure that the top lined disc (Z) fits snugly, though it must move freely in its slots.

- ◆ Apply some oil to the shaft (18) and insert it into the hole through the center of the main shaft.
- ◆ Install the spring-support cups (19).

NOTE There are different clutch versions.

For information regarding the components of the clutch, refer to the specific spare parts catalogue, according to the vehicle model on which the engine is installed, see 0.4.2 (SPARE PARTS CATALOGUE).

According to the clutch version.

The six clutch spring washers can be identified:

- normal (flat) washers (22);
- special (with collar) washers (22A).

CAUTION

In case of special washers (22A), pay attention to the correct assembly position (W) the collar must face in the direction of the clutch spring.

- ◆ Install the six clutch springs (20) in the appropriate recesses of the spring-support cups (19).

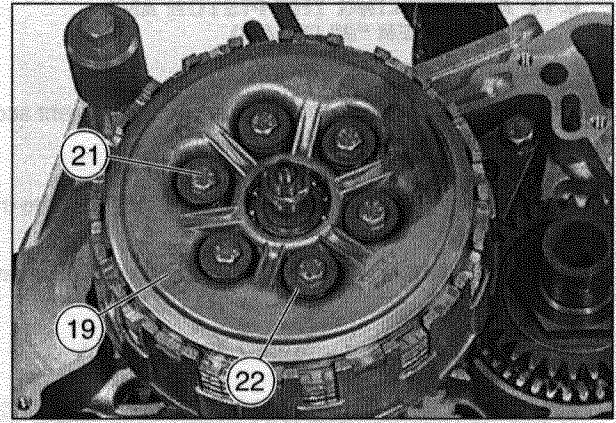

- ◆ Insert the six washers (22) on six M6x25 Allen screws (21)
- ◆ Screw in and tighten the six M6x25 Allen screws (21).

M6x25 Allen screws (21) tightening torque: 8 ftlb (11 Nm).

- C = LOCTITE® 648.
- E = LOCTITE® 767 Anti-Seize.
- O = Engine oil.

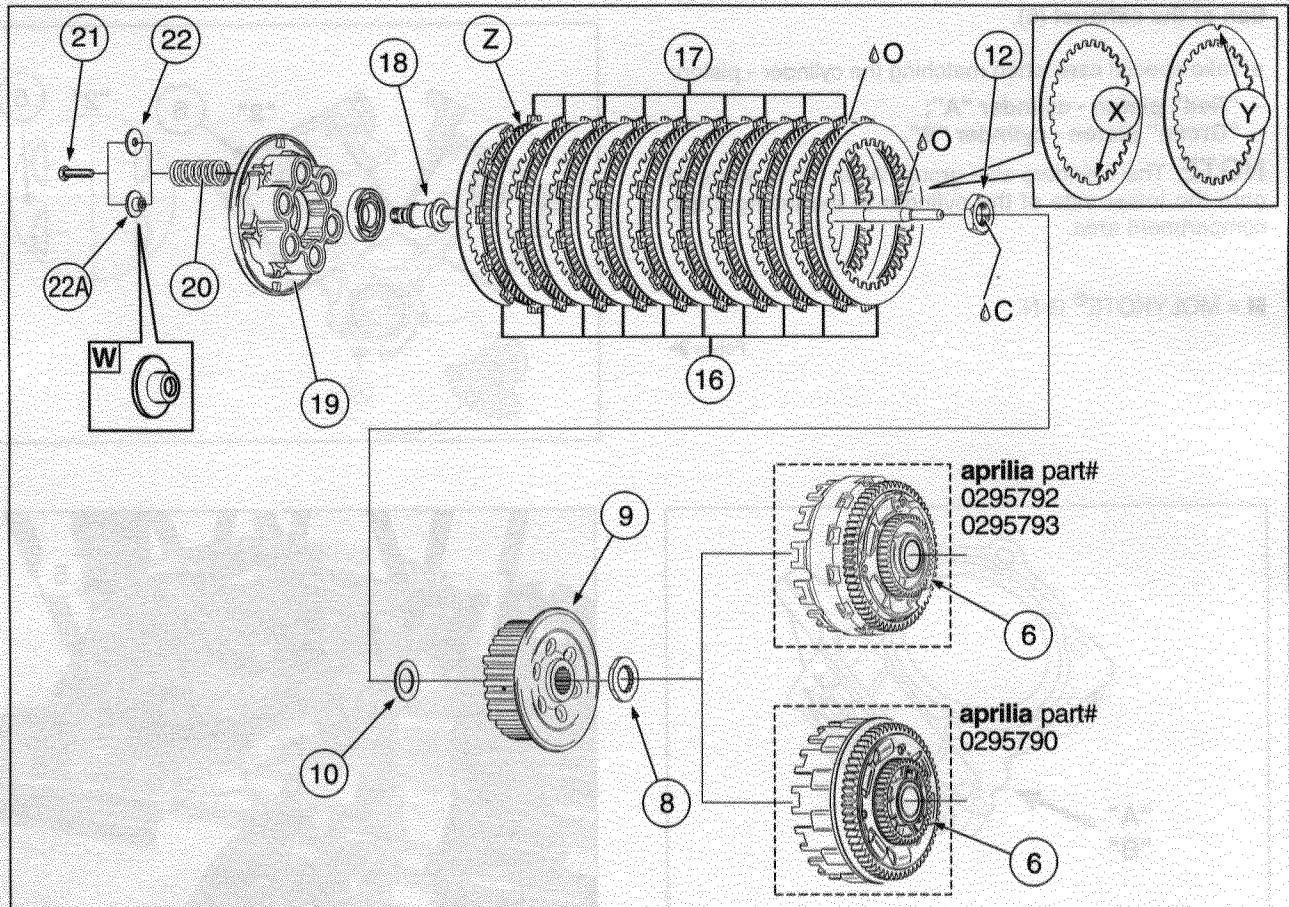

aprilia part#
0295792
0295793

aprilia part#
0295790

6.13 ASSEMBLING THE PISTON AND CYLINDER "2" (REAR)

Carefully read 6.1 (PREFACE).

- ◆ Place a rag as shown in the illustration, to prevent accidentally dropping parts into the crankcase.
- ◆ Insert the two locating dowels (1).

NOTE Apply a couple of drops of LOCTITE® 243 to the threads of the four M10 studs (2).

- ◆ Install the four M10 studs (2) into the engine case and tighten them.

M10 studs tightening torque: 7.2 ftlb (10 Nm).

CAUTION

Depending of the vehicle model on which the engine is installed, various versions of pistons are used, see 5.32.1 (PISTONS FEATURES CLASSIFICATION).

- ◆ Apply a thin coat of MOLYKOTE® G-N to the connecting rod small end and the gudgeon pin bore in the piston.
- ◆ Install the piston (3) to the connecting rod, and push the gudgeon pin (4) through the connecting rod small end bushing.

NOTE The gudgeon pin should be a light palm push in the piston and in the connecting rod. If you have to force the gudgeon pin at this point, something is wrong. Disassemble the piston from the connecting rod and determine where the problem lies.

CAUTION

Observe the orientation of parts, as marked upon disassembly.

If a new piston is used, the "red" or "green" reference mark (5) on the piston crown must face in the direction of the exhaust (6).

- ◆ Take special care when matching the cylinder - piston:
 - "Red" piston - cylinder "A";
 - "Green" piston - cylinder "B".

NOTE The cylinders size group "A" or "B" is stamped onto the lower side of the cylinder in the timing chain compartment area.

M = MOLYKOTE® G-N.

Follow ►

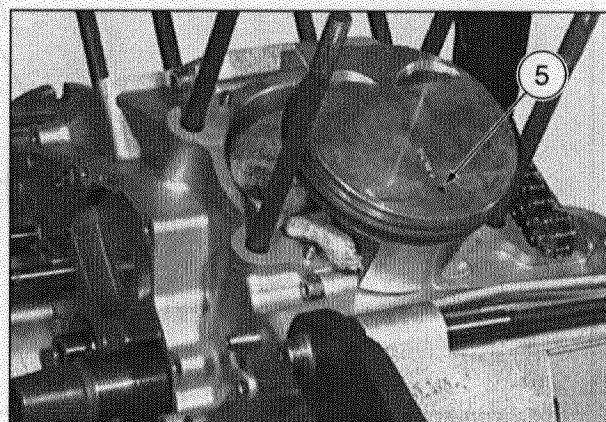
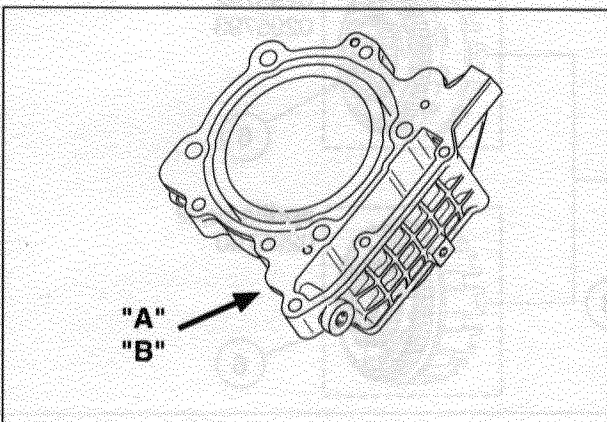
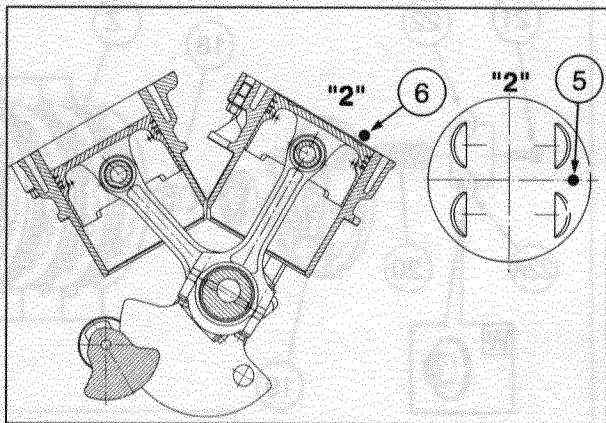
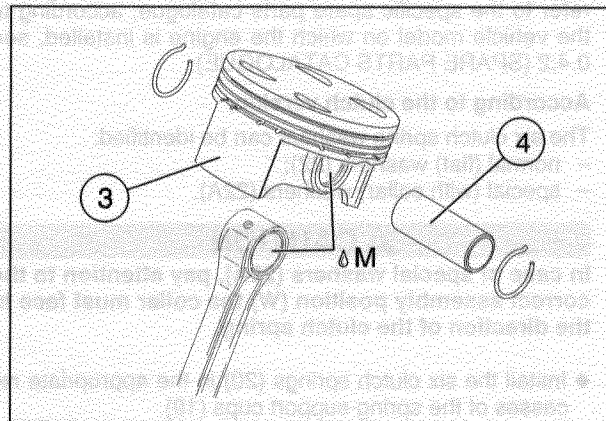
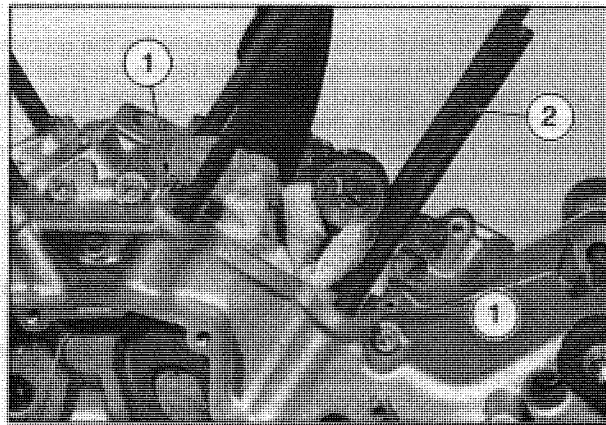

Follow ►

CAUTION

Use new bent-end gudgeon pin circlips (7) only.

- ◆ Install the gudgeon pin circlips (7).

NOTE Support the piston (3).
Ensure that the two gudgeon pin circlips (7) are inserted perfectly in the groove of the piston and that the hook (8) is inserted in the slot of the piston.

- ◆ Insert the two locating dowels (9) in the cylinder.

CAUTION

Use a new head gasket.

- ◆ Fit the head gasket (10) in place.
- ◆ Install the pre-assembled head on the cylinder and tighten the four shouldered screws (11).

Non-painted cylinder version:

- four shouldered screws (11) tightening torque 20.2 – 21.7 ftlb (28 – 30 Nm).

Painted cylinder version:

- four shouldered screws (11) tightening torque 18 – 20.2 ftlb (25 – 28 Nm).

- ◆ Apply a coat of LOCTITE® 574 on the engine case in the area of the parting line of the two halves of the case and on the mating surface between the cylinder and the crankcase.
- ◆ Install the cylinder base gasket on the case.
- ◆ Oil the piston and the piston rings thoroughly using engine oil.
- ◆ Turn the piston rings so that the gaps are staggered by approximately 120°.

Follow ►

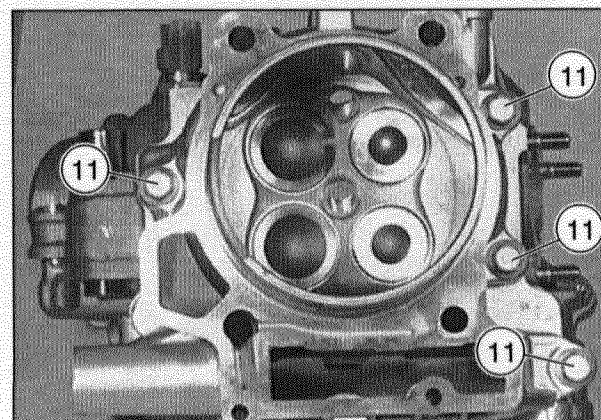
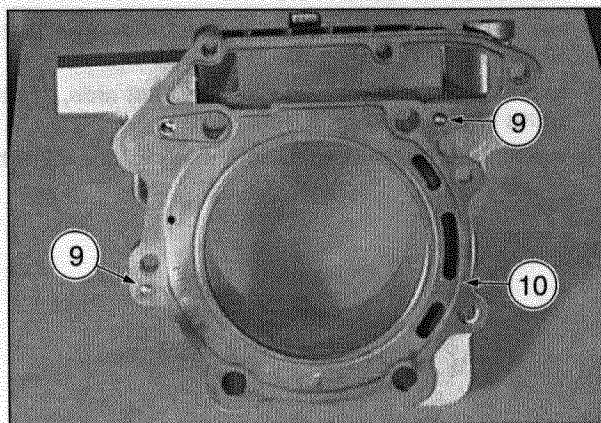
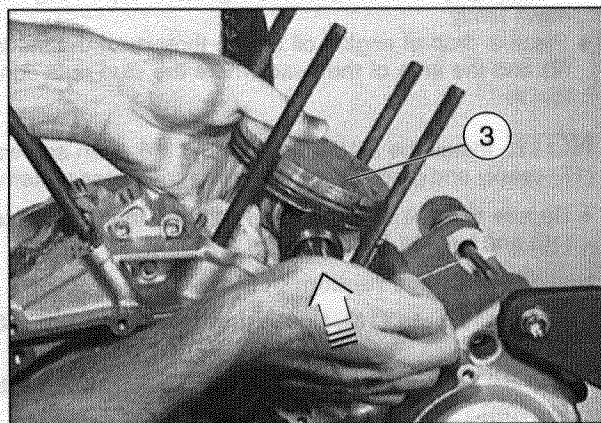
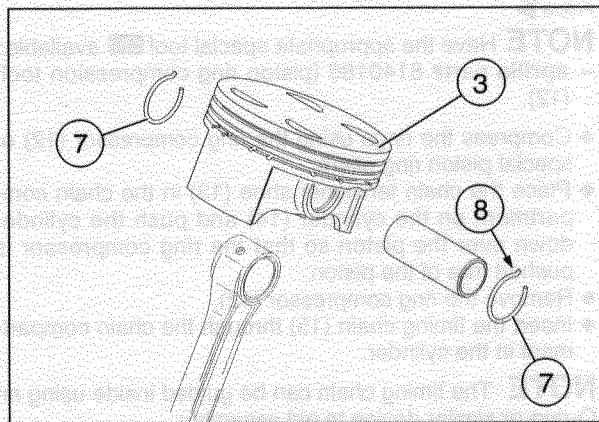

Follow ►

NOTE Have the appropriate special tool **OPT** available:
 – **aprilia** part# 8140186 (piston ring compression tool) (12).

- ◆ Compress the rings using the ring compressor (12) or special piston ring pliers.
- ◆ Place the chain tensioner shoe (13) in the chain compartment on the cylinder (14) and push the cylinder down over the piston so that the ring compressor is pushed free of the piston.
- ◆ Remove the ring compressor (12).
- ◆ Insert the timing chain (15) through the chain compartment in the cylinder.

NOTE The timing chain can be guided inside using an O-ring or similar device to aid assembly.

- ◆ Install the cylinder (14) on the engine case, pushing it in down firmly.
- ◆ Place a drop of engine oil on the threads of the studs (2) and the area of the head where the stud nuts contact it.

NOTE Install the M10 nuts (16) and M6 Allen screws (17) evenly and gradually, working in a crisscross pattern.

- ◆ Secure the cylinder and head with the four M10 nuts (16) and two M6 Allen screws (17).

Non-painted head version:

- four M10 nuts (16), tightening torque 42 ftlb (58 Nm);
- two M6 Allen screws (17), tightening torque 8.7 ftlb (12 Nm).

Painted head version:

- two M10 nuts (16), external, tightening torque 36.2-39.8 ftlb (50-55 Nm);
- two M10 nuts (16), chain compartment side, tightening torque 42 ftlb (58 Nm);
- two M6 Allen screws (17), tightening torque 8.7 ftlb (12 Nm).

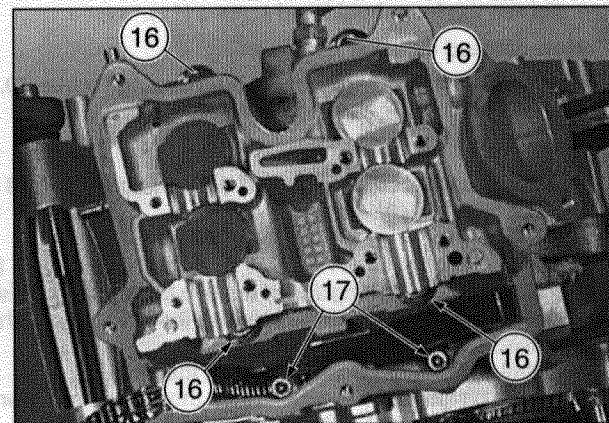
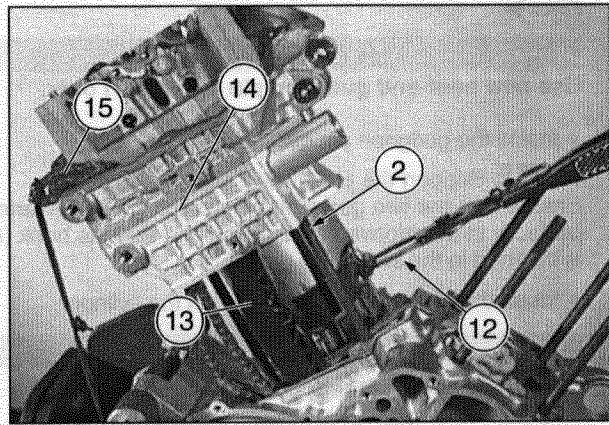

6.14 ADJUSTING VALVE CLEARANCE

Carefully read 6.1 (PREFACE).

⚠ CAUTION

Check and, where necessary, adjust the valve clearance:

- at periodic intervals, consult the section 2 (SERVICE AND SETTING UP) of specific vehicle workshop manual see 0.4.1 (VEHICLE WORKSHOP MANUAL);
- every time the timing drive assembly is repaired or taken apart.;
- every time the head or camshaft is taken apart.

The valve clearance adjustment must be performed with the engine at room temperature.

NOTE The size is stamped on the adjustment shim. Insert the adjustment shims with the size numbers facing toward the bottom of the engine. Before fitting them, always measure the adjustment shims with a micrometer.

- ◆ Insert the adjustment shims (1) in the valve spring housings (2).
- ◆ Oil the external diameter of the four valve lifter buckets (3) and insert them in the head.
- ◆ Oil the four camshaft bushings (4) inside the head.
- ◆ Fit the exhaust camshaft (5) and intake camshaft (6) with the cam lobe facing up.

⚠ CAUTION

Depending of the vehicle model on which the engine is installed, various versions of camshaft are used, see 5.26.1 (CAMSHAFTS FEATURES CLASSIFICATION).

- ◆ Install the camshaft by hand hold it in place, and measure the valve clearance with a feeler gauge.
- ◆ Note the valve clearance measured.
- ◆ Compute the difference between the specification value and the actual value.

Valve clearance:

- intake valve 0.0047 – 0.0067 in (0.12 – 0.17 mm);
- exhaust valve 0.0090 – 0.011 in (0.23 – 0.28 mm).
- ◆ Where necessary, replace the adjustment shim (1).

⚠ CAUTION

- Intake valve: the 0.0059 in (0.15 mm) gauge should 'go', the 0.0079 in (0.20 mm) feeler gauge must 'not go'.
- Exhaust valve: the 0.0098 in (0.25 mm) gauge must 'go', the 0.012 in (0.3 mm) gauge must 'not go'.

M = MOLYKOTE® G-N.
O = Engine oil.

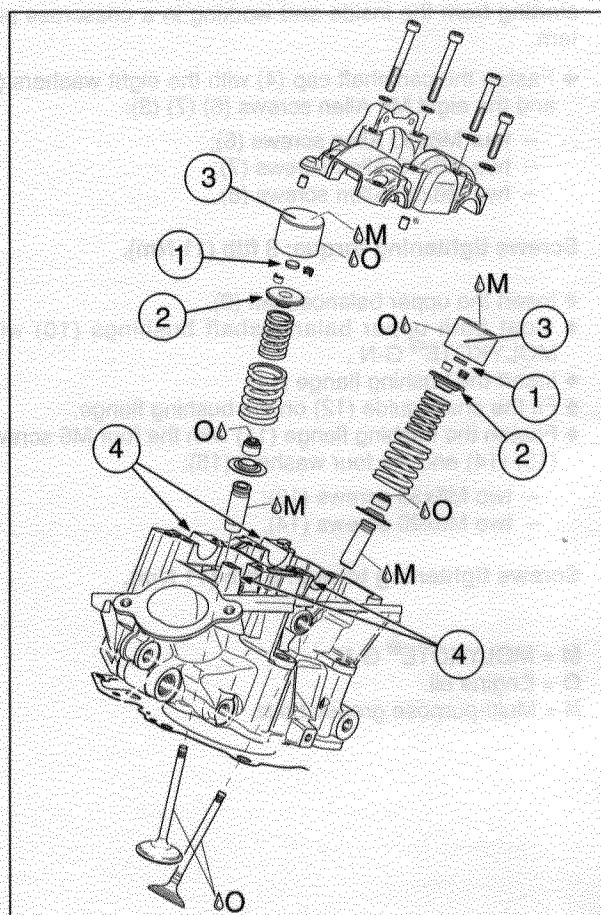
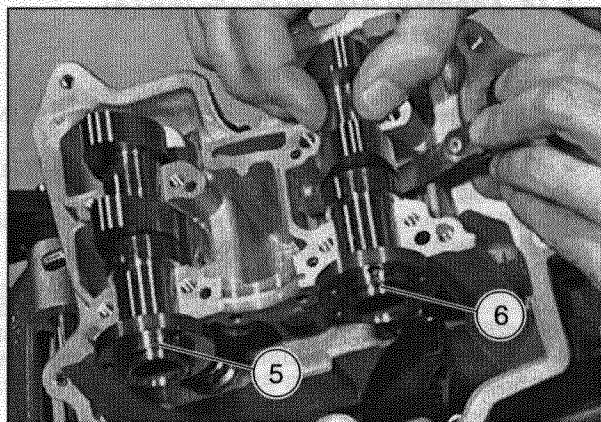

6.15 ASSEMBLING HEAD "2" (REAR) CAMSHAFT

Carefully read 6.1 (PREFACE).

- ◆ Adjust the valve clearance, see 6.14 (ADJUSTING VALVE CLEARANCE).
- ◆ Oil the housings of the exhaust camshaft (1) and intake camshaft (2).
- ◆ Coat the cams (3) with MOLYKOTE® G-N and insert the camshafts in the head.

CAUTION

Depending of the vehicle model on which the engine is installed, various versions of camshaft are used, see 5.26.1 (CAMSHAFTS FEATURES CLASSIFICATION).

NOTE Tighten the camshaft bearing cap gradually, starting from the inside and working in a crisscross pattern.

- ◆ Fasten the camshaft cap (4) with the eight washers (5) and the eight M6 Allen screws (6) (7) (8):
 - four M6x30 Allen screws (6);
 - two M6x45 Allen screws (7);
 - two M6x55 Allen screws (8).

Screws tightening torque: 8 ftlb (11 Nm).

- ◆ Insert the upper balancershaft (9).
- ◆ Coat both upper balancershaft bushings (10) with MOLYKOTE® G-N.
- ◆ Insert the bushing flange (11).
- ◆ Fit the chain guide (12) on the bushing flange.
- ◆ Fasten the bushing flange (11) with the four M6 screws (13) (14) and the four washers (15):
 - two M6x35 screws (13);
 - two M6x20 screws (14).

Screws tightening torque: 8 ftlb (11 Nm).

- M = MOLYKOTE® G-N.
- O = Engine oil.
- N = Multi-purpose grease bp lz.

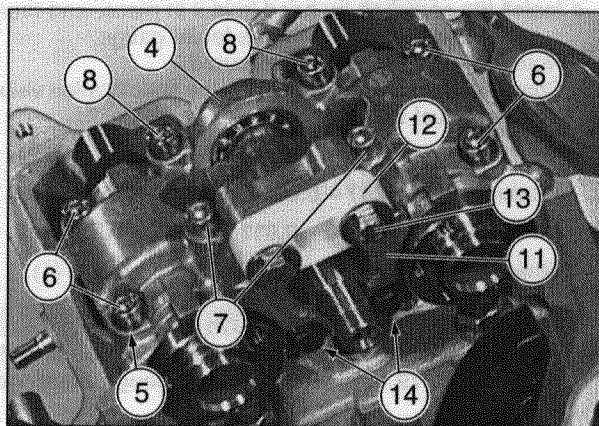
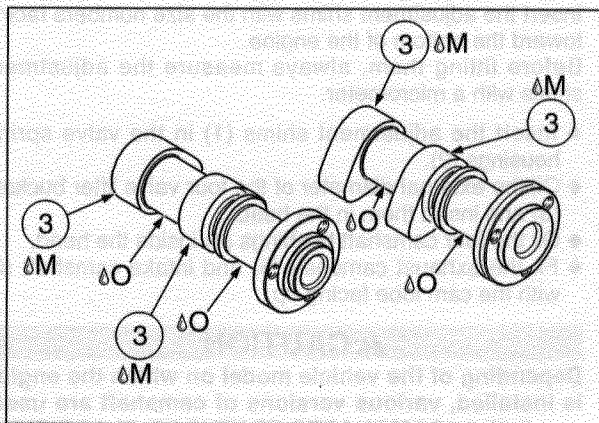
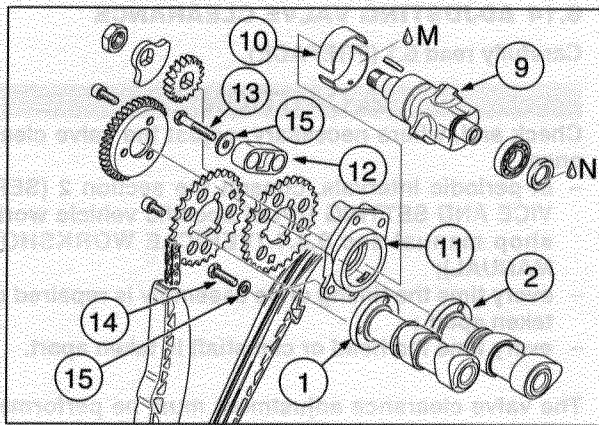

6.16 ASSEMBLING HEAD "2" (REAR) TIMING DRIVE ASSEMBLY

Carefully read 6.1 (PREFACE).

NOTE The crankshaft must be locked at Top Dead Center (TDC) on cylinder "2" (rear), see 4.14 [DISASSEMBLING CYLINDER "2" (REAR) TIMING DRIVE ASSEMBLY].

- ◆ Turn the camshaft so the cam lobes (1) face away from each other.
- ◆ Install the camshaft sprocket (2) on the exhaust camshaft and line up the bolt holes.

NOTE In order to make assembly easier, the camshaft sprocket can be secured in place temporarily with an M6 Allen screw.

- ◆ Turn the camshaft sprocket (2) and the exhaust camshaft (3) until the "EX" reference mark (4) faces the center of the intake camshaft.
- ◆ Place the timing chain (5) over the camshaft sprocket (2) and under the chain guide (6).

NOTE The timing chain must be taut on the tension side (7).

- ◆ Put the intake camshaft sprocket (8) in place, engaging its teeth in the timing gear so that the "IN" reference mark (9) faces the "EX" reference mark (4) on the exhaust camshaft sprocket.
- ◆ Maintaining this position, push the intake camshaft sprocket (8) onto the intake camshaft and line up the holes in the sprocket with those on the camshaft.

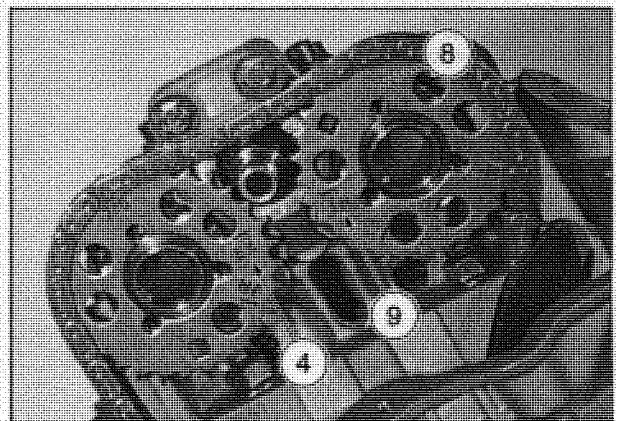
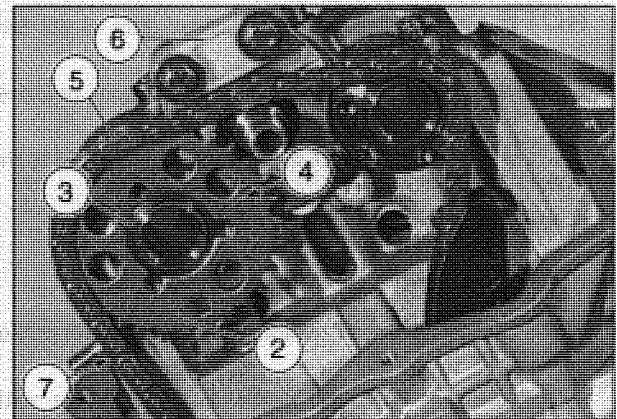
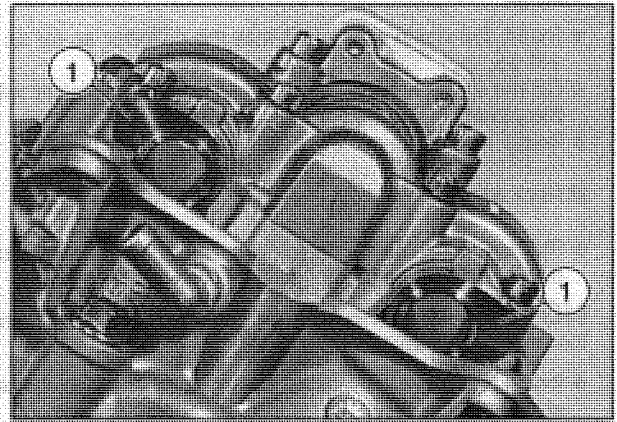

▲ WARNING

Use only the three originally supplied Allen M6 x 14 (11) screws with the exhaust camshaft sprocket (10). Use of any other fasteners can lead to engine failure, seizure, and subsequent injury or even death.

NOTE Apply a couple of drops of LOCTITE® 243 to the threads of the three M6x14 Allen screws (11).

- ◆ Push the exhaust camshaft sprocket (10) onto the exhaust camshaft and fasten it with the three M6x14 Allen screws (11).

M6x14 screws tightening torque: 8 ftlb (11 Nm).

NOTE Apply a couple of drops of LOCTITE® 243 to the threads of the three M6x10 Allen screw (12).

- ◆ Secure the intake camshaft sprocket with three M6x10 Allen screws (12)

M6x10 screws tightening torque: 8 ftlb (11 Nm).

B = LOCTITE® 243.

N = Multi-purpose grease bp lz.

Follow ▶

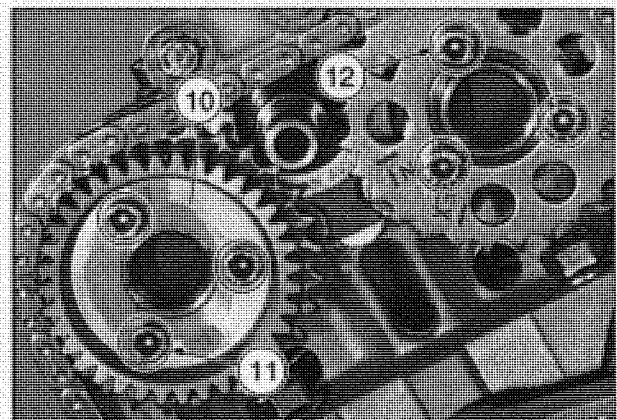
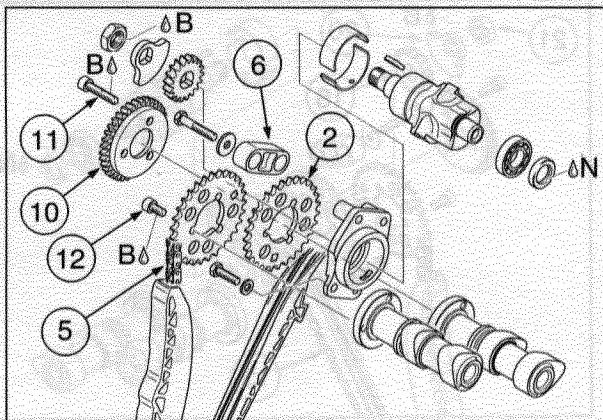

Follow ►

- ◆ Insert the chain guide (13) into the cylinder as far as it will go.
- ◆ Oil the chain tightener (14) and fit it in the cylinder with the closed end facing the chain tensioner shoe (15).
- ◆ Install and tighten the M18x1 screw (16) and seal.

M18x1 screw tightening torque: 14.5 ftlb (20 Nm).

- ◆ Place a rag as shown in the illustration, to prevent accidentally dropping parts into the chain compartment.

NOTE Be careful to keep the key (17) from dropping into the chain compartment.

- ◆ Insert the key (17) into its seat on the upper balance-shaft.
- ◆ Install the gear (18) onto the upper balanceshaft so that the two reference marks (19) are lined up.

NOTE Ensure that the sharp-edged side of the balanceweight faces inward.

- ◆ Install the balanceweight (20) on the upper balance-shaft.

NOTE Apply a couple of drops of LOCTITE® 243 to the threads of the M14x1 nut.

- ◆ Install the M14x1 nut (21) and tighten it.

M14x1 nut tightening torque: 36 ftlb (50 Nm).

NOTE Hold the upper balanceshaft using a drift (22) or similar tool.

- ◆ Coat the valve lifter bucket and the cams with MOLYKOTE® G-N.

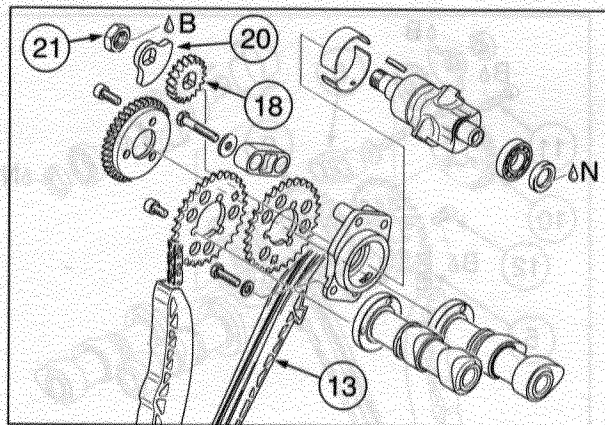
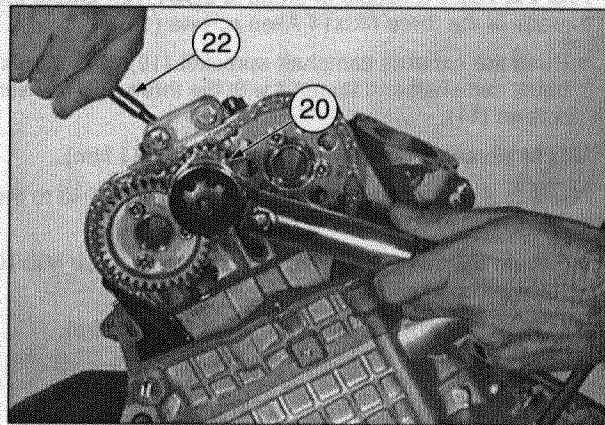
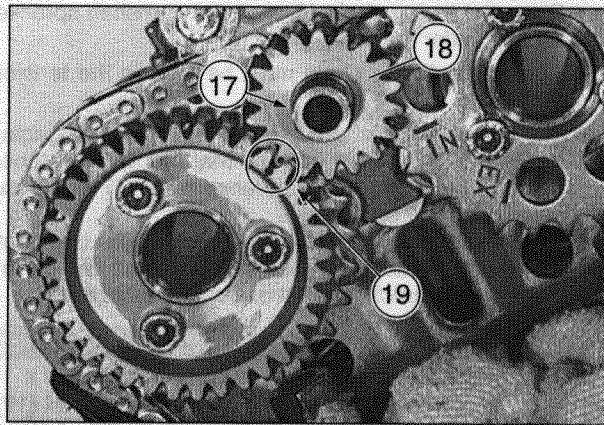
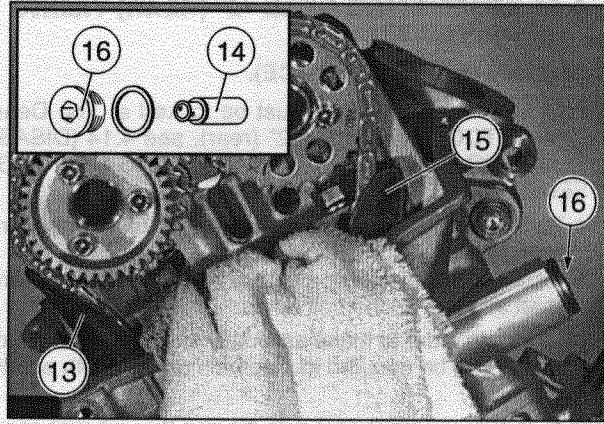

B = LOCTITE® 243.
N = Multi-purpose grease bp lz.

6.17 ASSEMBLING HEAD "1" (FRONT) TIMING DRIVE ASSEMBLY

Carefully read 6.1 (PREFACE).

- ◆ Remove the setscrew (1) and turn the crankshaft (2) 300° counterclockwise so that the connecting rod (3) of cylinder "1" is at TDC.

NOTE Hold the connecting rod (3) in the center of the crankcase, so that it does not foul the crankcase as you turn the crankshaft.

- ◆ Screw the setscrew (1) back in.

NOTE Ensure that the setscrew properly engages the crankshaft slot.

The setscrew (1) must not be overtightened:

Setscrew tightening torque: max. 3.6 ftlb (5 Nm).

NOTE Engines # 527 354 and later, the locating dowels (4) are not employed. Centering is achieved by a modification to the bearing support flange (11).

- ◆ If not previously done, install the two locating dowels (4) in the case.

NOTE Work very carefully while installing these dowels, they are a tight press fit.

- ◆ Install the thrust washer (5) on the intermediate timing gear (6), using a little grease.
- ◆ Wrap the timing chain (7) around the intermediate timing gear (6). Fasten the timing chain through the chain compartment. Install the intermediate timing gear.

NOTE Line up the reference marks made during disassembly on the timing chain and intermediate gear.

- ◆ Guide the chain tensioner shoe (8) through the chain compartment and install it in the housing using the spacer sleeve (9).
- ◆ Oil the two roller bearings (10) and push them onto the pin of the bearing support flange (11).
- ◆ Install the bearing support flange (11) pushing it on as far as it will go, tapping lightly with a mallet.

NOTE Apply a couple of drops of LOCTITE® 243 to the threads of the four M6x20 Allen screw (15).

- ◆ Fasten the bearing flange (11) with the M8x20 screw (12), M8x45 screw (13), spring washers (14) and M6x20 Allen screw (15).
 - one M8x20 screw (12).
 - one M8x45 screw (13).
 - one M6x20 Allen screw (15).

Tightening torque:

- M8x20 screw: 18 ftlb (25 Nm);
- M8x45 screw: 18 ftlb (25 Nm);
- M6 Allen screw: 8 ftlb (11 Nm).

B = LOCTITE® 243.

O = Engine oil.

N = Multi-purpose grease bp lz.

Follow ▶

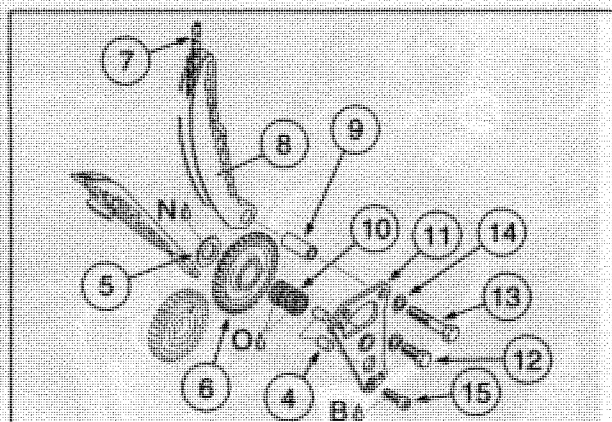
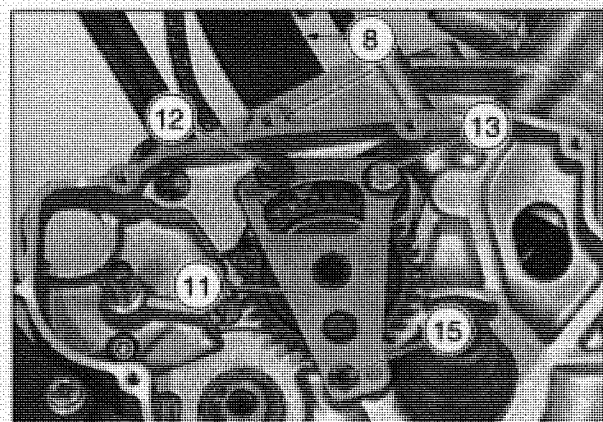
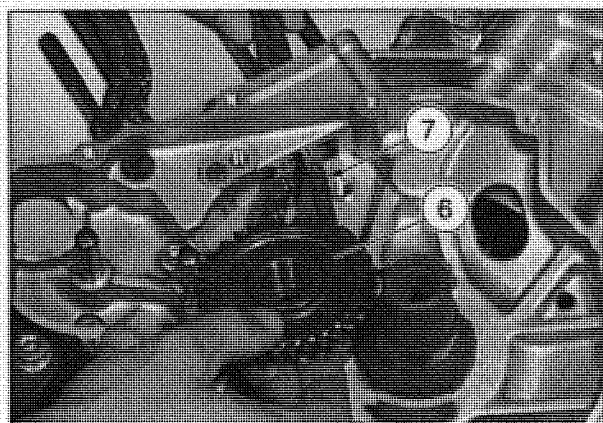
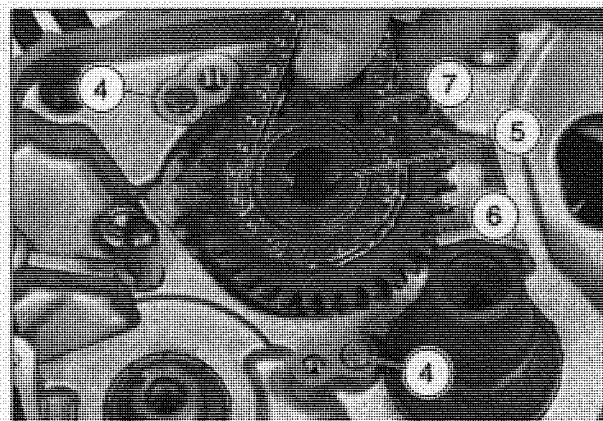
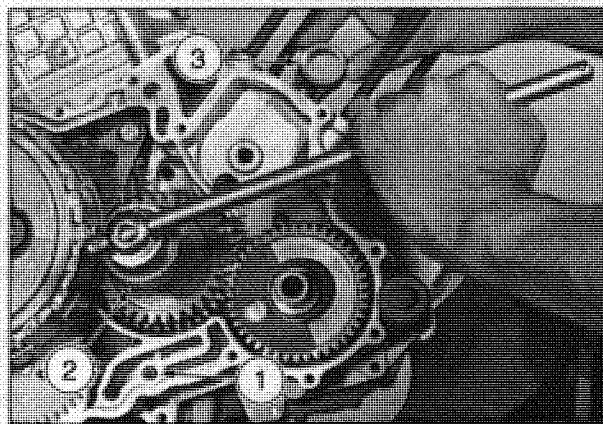

Follow ►

- ◆ Rotate the intermediate timing gear (6) so that the two reference marks (16) are lined up with each other.
- ◆ Install the balanceweight (17) on the upper balance-shaft.
- ◆ Insert the key (18) into its seat in the balancershaft.
- ◆ Install the gear (19) and balanceweight (20).

NOTE The woodruff key (18) must engage the inner balanceweight keyway. Ensure that the reference mark on the intermediate drive gear is matched to the reference mark (16) on the bearing flange.

NOTE Apply a couple of drops of LOCTITE® 648 to the threads of the M10 Allen screw (21).

- ◆ Install, in the upper balancershaft, the M10 Allen screw (21) and tighten it.

Screw tightening torque: 36 ftlb (50 Nm).

NOTE The balancershaft is timed when the cams of cylinder "2" are timed.

C = LOCTITE® 648.

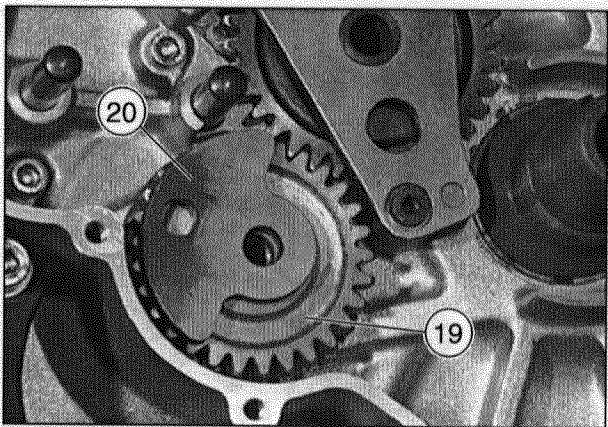
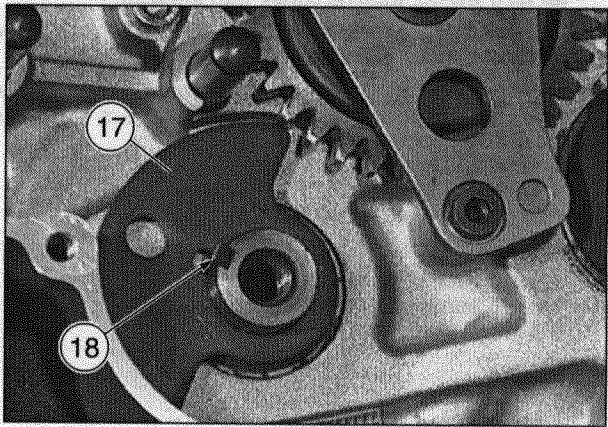
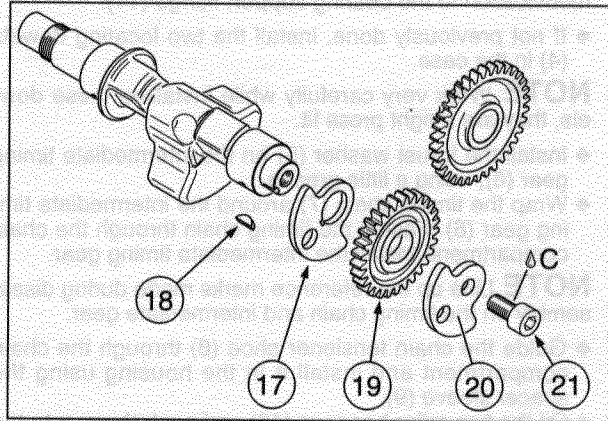
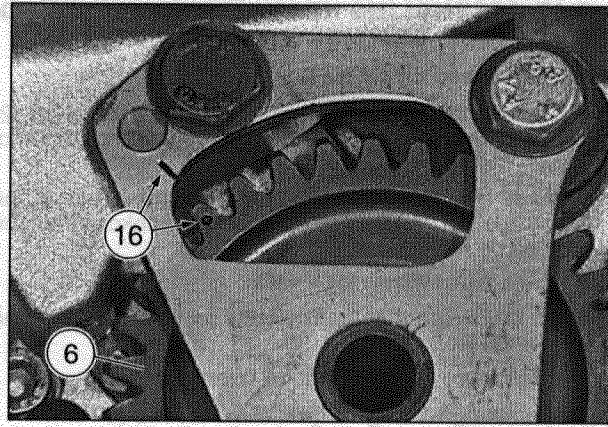

6.18 ASSEMBLING THE STARTER MOTOR DRIVE ASSEMBLY AND ALTERNATOR

Carefully read 6.1 (PREFACE).

NOTE Lock the crankshaft at the TDC of piston "1" or "2".

- ◆ Oil the two pins (1) and coat the housing (2) of the sprag clutch gear on the crankshaft with MOLYKOTE® G-N.
- ◆ Insert the double starter gear (3), idler gear (4) and sprag clutch gear (5).
- ◆ Oil the surface (6) on the sprag clutch gear (5).
- ◆ **RSV RSV R SL** Assemble the alternator rotor (7), see 5.34 (ALTERNATOR **RSV RSV R SL**).
- ◆ **RST ETV** Assemble the alternator rotor (7), see 5.35 (ALTERNATOR **RST ETV**).
- ◆ Oil the sprag clutch (8) inside the housing (9).
- ◆ Degrease the taper (10) of the crankshaft and the taper (11) of the alternator rotor hub.

NOTE Upon assembly, take care to prevent LOCTITE® from penetrating inside the seat (12) of the sprag clutch gear (5).

- ◆ Apply a couple of drops of LOCTITE® 648 to the taper (11) of the alternator rotor hub.

NOTE To facilitate the insertion, turn the alternator rotor (7) until aligning the keyway (13) on the alternator rotor hub with the crankshaft key (14).

- ◆ Install the complete alternator rotor (7) onto the taper (10) of the crankshaft, so that the crankshaft key (14) engages the keyway (13) in the alternator rotor hub.
- ◆ Fit the washer (15) on the alternator rotor M16 Allen screw (16).

NOTE Apply a couple of drops of LOCTITE® 648 to the threads of the M16 Allen screw (16).

- ◆ Install and tighten the alternator rotor screw (16) on the crankshaft.

Alternator rotor M16 Allen screw (16) tightening torque: 94 ftlb (130 Nm).

C = LOCTITE® 648.
O = Engine oil.

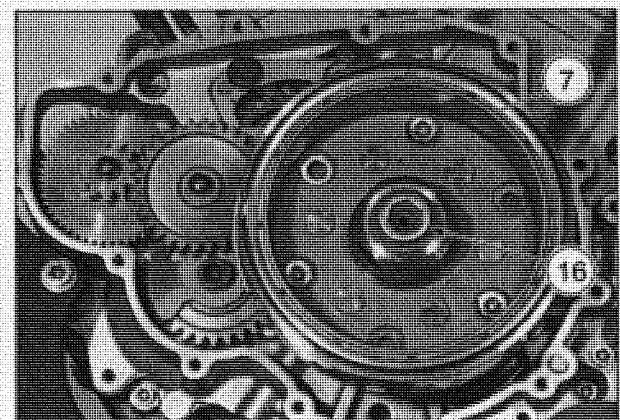
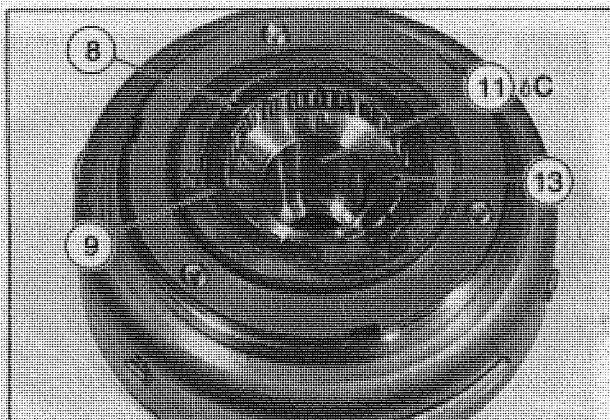
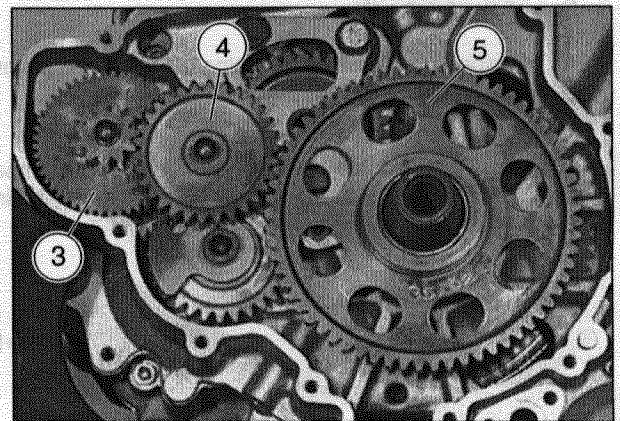
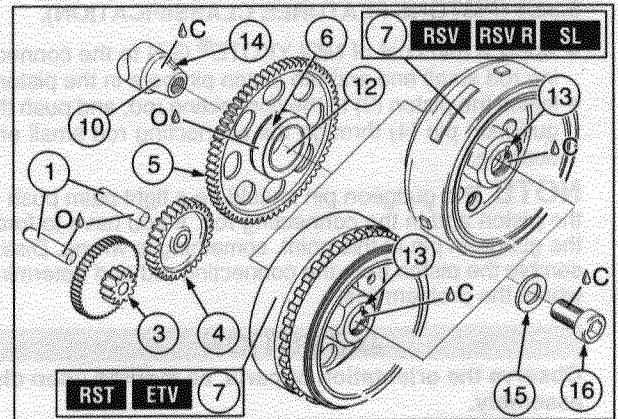
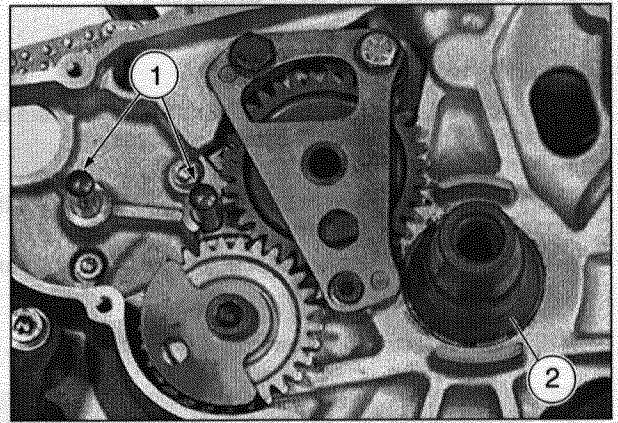

6.19 ASSEMBLING THE PISTON AND CYLINDER "1" (FRONT)

Carefully read 6.1 (PREFACE).

- ◆ Place a rag, as shown in the illustration, to prevent accidentally dropping parts into the crankcase.
- ◆ Insert the two locating dowels (1).

NOTE Apply a couple of drops of LOCTITE® 243 to the threads of the four M10 studs (2).

- ◆ Install, into the engine case, the four M10 studs (2) and tighten it.

M10 studs tightening torque: 10.8 ftlb (15 Nm).

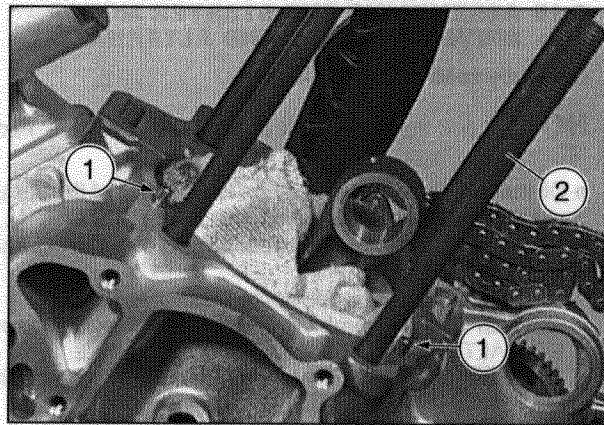

CAUTION

Depending of the vehicle model on which the engine is installed, various versions of pistons are used, see 5.32.1 (PISTONS FEATURES CLASSIFICATION).

- ◆ Apply a thin coat of MOLYKOTE® G-N to the connecting rod small end and the piston pin bore in the piston.
- ◆ Install the piston (3) to the connecting rod, and push the gudgeon pin (4) through the connecting rod small end bushing.

NOTE The gudgeon pin should be a light palm push in the piston and in the connecting rod. If you have to force the gudgeon pin at this point, something is wrong. Disassemble the piston from the connecting rod and determine where the problem lies.

CAUTION

Observe the orientation of parts, as marked upon disassembly.

If a new piston is used, the "red" or "green" reference mark (5) on the piston crown must face in the direction of the intake (6).

- ◆ Take special care when matching the cylinder - piston:
 - "Red" piston - cylinder "A";
 - "Green" piston - cylinder "B".

NOTE The cylinders size group "A" or "B" is stamped onto the lower side of the actual cylinder in the timing chain compartment area.

M = MOLYKOTE® G-N.

Follow ▶

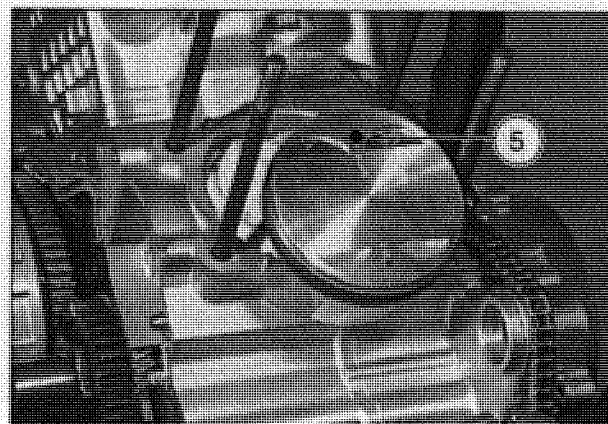
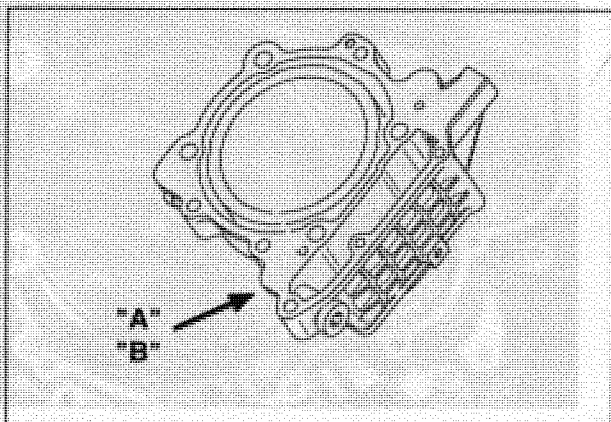
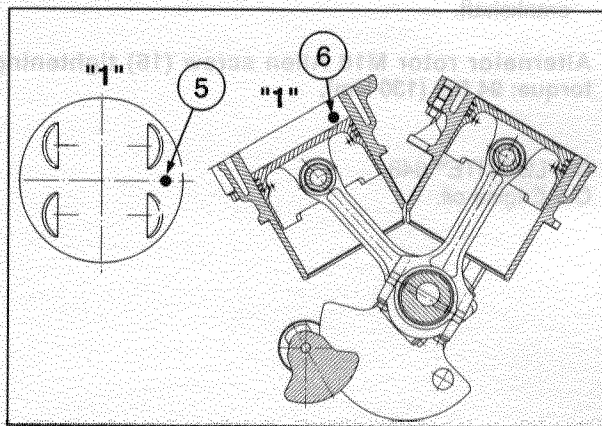
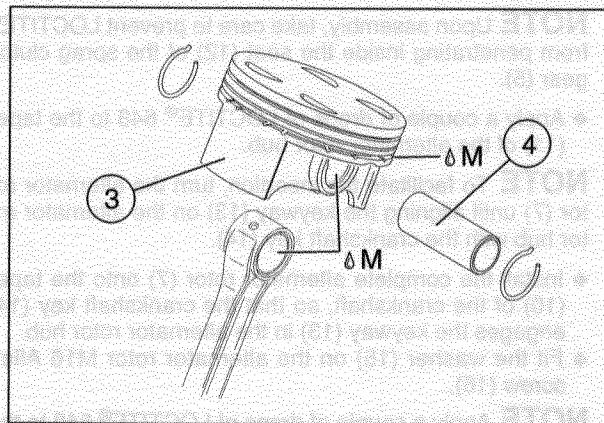

Follow ►

CAUTION

Use new bent-end gudgeon pin circlips (7) only.

- ◆ Install the gudgeon pin circlips (7).

NOTE Support the piston (3).
Ensure that the two gudgeon pin circlips are inserted perfectly in the groove of the piston and that the hook (8) is inserted in the slot of the piston.

- ◆ Insert the two locating dowels (9) in the cylinder.

CAUTION

Use a new head gasket.

- ◆ Fit the head gasket (10) in place.
- ◆ Install the pre-assembled head on the cylinder and tighten the four shouldered screws (11).

Non-painted cylinder version:

- four shouldered screws (11) tightening torque: 21 ftlb (29 Nm).

Painted cylinder version:

- four shouldered screws (11) tightening torque: 19.5 ftlb (27 Nm).

- ◆ Apply a coat of LOCTITE® 574 on the engine case in the area of the parting line of the two halves of the case, on the mating surface between the cylinder and the crankcase.
- ◆ Install the cylinder base gasket on the case.
- ◆ Oil the piston and the piston rings thoroughly using engine oil.
- ◆ Turn the piston rings so that the gaps are staggered by approximately 120°.

Follow ►

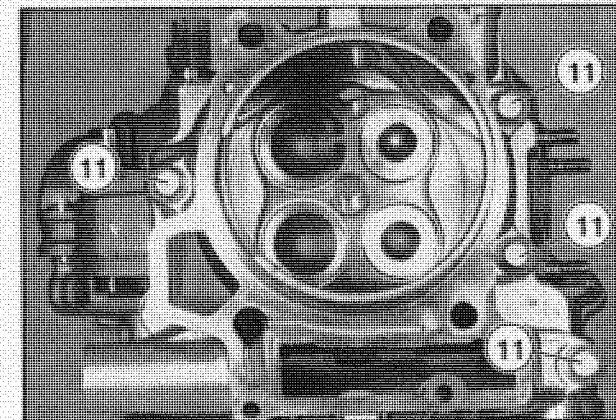
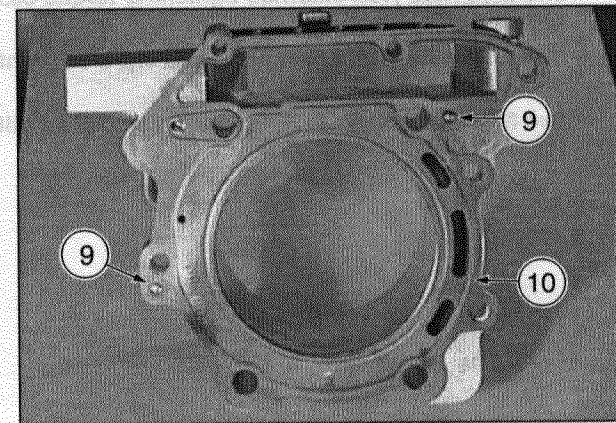
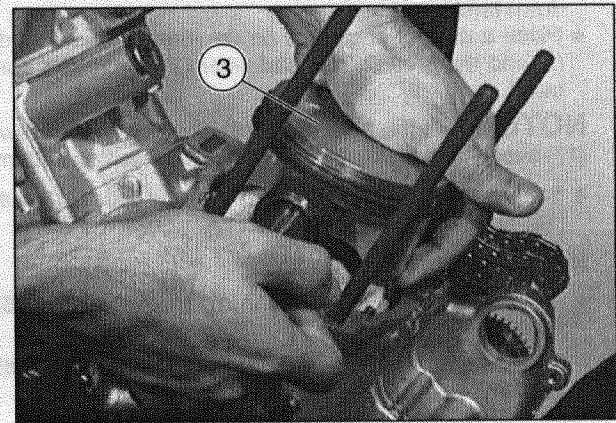
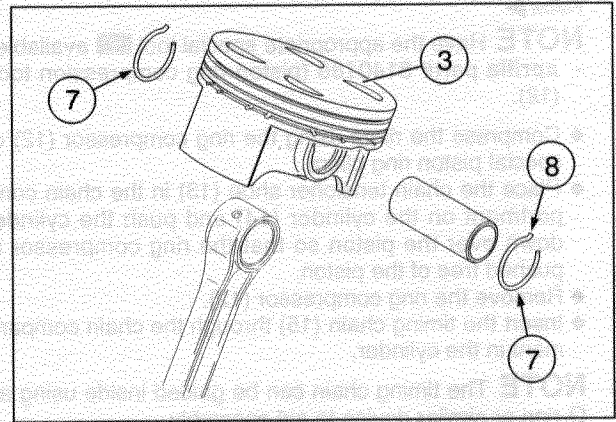

Follow ►

NOTE Have the appropriate special tool **OPT** available:
 – **aprilia** part# 8140186 (piston ring compression tool) (12).

- ◆ Compress the rings using the ring compressor (12) or special piston ring pliers.
- ◆ Place the chain tensioner shoe (13) in the chain compartment on the cylinder (14) and push the cylinder down over the piston so that the ring compressor is pushed free of the piston.
- ◆ Remove the ring compressor (12).
- ◆ Insert the timing chain (15) through the chain compartment in the cylinder.

NOTE The timing chain can be guided inside using an O-ring or similar device to aid assembly.

- ◆ Install the cylinder (14) on the engine case, pushing it down firmly.
- ◆ Place a drop of engine oil on the threads of the studs (2) and the area of the head where the stud nuts contact it.

NOTE Install the M10 nuts (16) and M6 Allen screws (17) evenly and gradually, working in a crisscross pattern.

- ◆ Secure the cylinder and head with the four M10 nuts (16) and two M6 Allen screws (17).

Non-painted head version:

- four M10 nuts (16), tightening torque 42 ftlb (58 Nm);
- two M6 Allen screws (17), tightening torque 8.7 ftlb (12 Nm).

Painted head version:

- two M10 nuts (16), external, tightening torque 38.3 ftlb (53 Nm);
- two M10 nuts (16), chain compartment side, tightening torque 42 ftlb (58 Nm);
- two M6 Allen screws (17), tightening torque 8.7 ftlb (12 Nm).

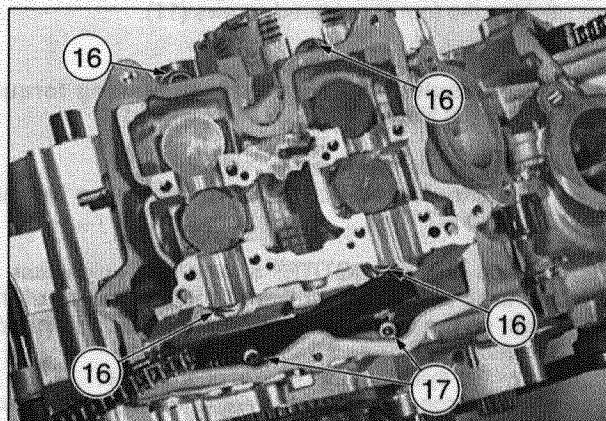
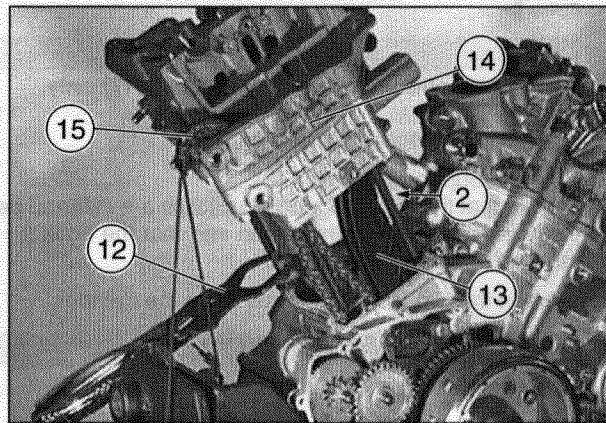

6.20 ASSEMBLING HEAD "1" (FRONT) CAMSHAFT

Carefully read 6.1 (PREFACE).

- ◆ Adjust the valve clearance, see 6.14 (ADJUSTING VALVE CLEARANCE).
- ◆ Oil the housings of the exhaust camshaft (1) and intake camshaft (2).
- ◆ Coat the cams (3) with MOLYKOTE® G-N and insert the camshafts in the head.

CAUTION

Depending of the vehicle model on which the engine is installed, various versions of camshaft are used, see 5.26.1 (CAMSHAFTS FEATURES CLASSIFICATION).

NOTE Tighten the camshaft bearing cap gradually, starting from the inside and working in a crisscross pattern.

- ◆ Fasten the camshaft cap (4) with the seven washers (5) and seven M6x30 Allen screws (6).

Screws tightening torque: 8 ftlb (11 Nm).

NOTE Apply a couple of drops of LOCTITE® 243 to the threads of the two M5 Taptite screws (8).

- ◆ Fit the camshaft sensor (7), secure it in place with two M5 Taptite screws (8), and fastening them.

M5 Taptite screws tightening torque: 2.9 ftlb (4 Nm).

- ◆ Insert the camshaft sensor cable in the guide (9) and fasten it with the cable clamp (10) and M6X30 Allen screw (11).

Screw tightening torque: 8 ftlb (11 Nm).

B = LOCTITE® 243.
Q = SILASTIC 732 RTV.

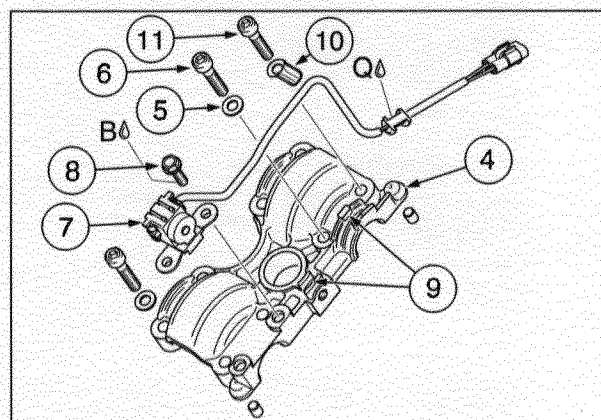
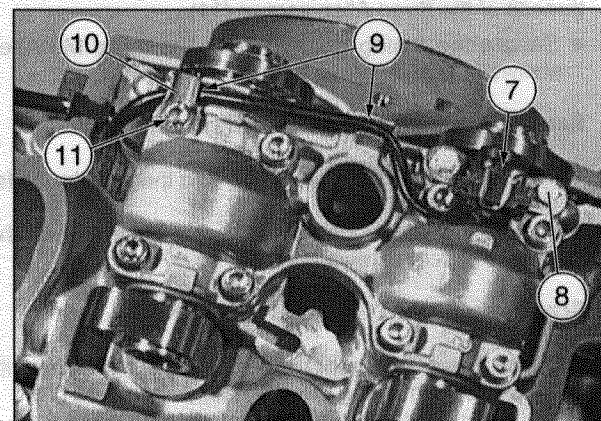
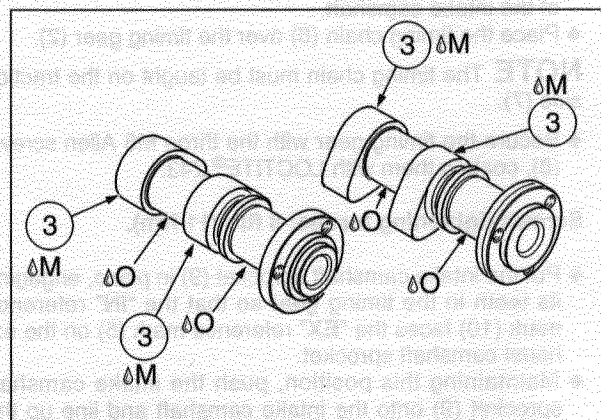
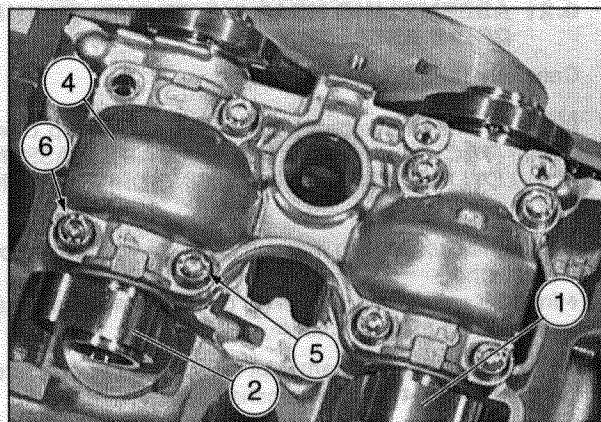

6.21 ASSEMBLING HEAD "1" (FRONT) TIMING DRIVE ASSEMBLY

Carefully read 6.1 (PREFACE).

NOTE The crankshaft must be locked at Top Dead Center (TDC) on cylinder "1" (front), see 4.9 [DISASSEMBLING CYLINDER "1" (FRONT) TIMING DRIVE ASSEMBLY].

- ◆ Turn the camshaft so the cam lobes (1) face away from each other.
- ◆ Install a camshaft sprocket (2) on the exhaust camshaft and line up the bolt holes.

NOTE The exhaust camshaft sprocket (2) incorporates the transducer (4) for the camshaft sensor.

- ◆ Turn the camshaft sprocket (2) and the exhaust camshaft until the "EX" reference mark (5) faces the center of the intake camshaft.
- ◆ Place the timing chain (6) over the timing gear (2).

NOTE The timing chain must be taugth on the traction side (7).

- ◆ Secure the timing gear with the three M6 Allen screws (8), coating them with LOCTITE® 243.

Screws tightening torque: 8 ftlb (11 Nm).

- ◆ Put the intake camshaft sprocket (9) in place, engaging its teeth in the timing gear so that the "IN" reference mark (10) faces the "EX" reference mark (5) on the exhaust camshaft sprocket.
- ◆ Maintaining this position, push the intake camshaft sprocket (9) onto the intake camshaft and line up the holes in the sprocket with those on the camshaft.

NOTE Apply a couple of drops of LOCTITE® 243 to the threads of the three Allen screws (11).

- ◆ Secure the timing gear (9) with the three M6 Allen screws (11) and tighten them.

Screws tightening torque: 8 ftlb (11 Nm).

- ◆ Insert the chain guide shoe (12) into the cylinder as far as it will go.
- ◆ Fit the chain guide bracket (13) and secure it with the two M6 spacer screws (14).

Screws tightening torque: 8 ftlb (11 Nm).

- ◆ Oil the chain tightener (15) and fit it in the cylinder with the closed end facing the chain tensioner shoe (16).
- ◆ Install and tighten the M18x1 screw (17) and seal.

M8x1 screws tightening torque: 14.5 ftlb (20 Nm).

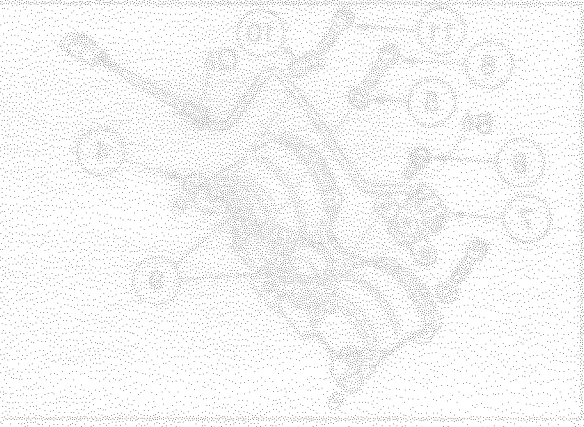
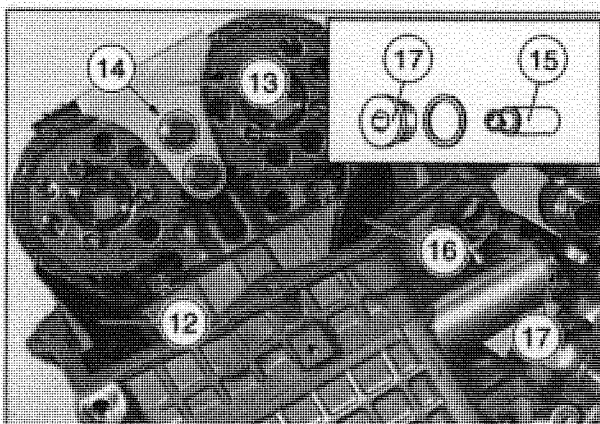
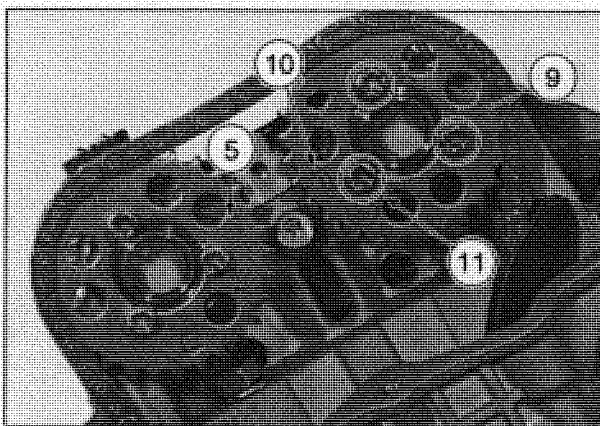
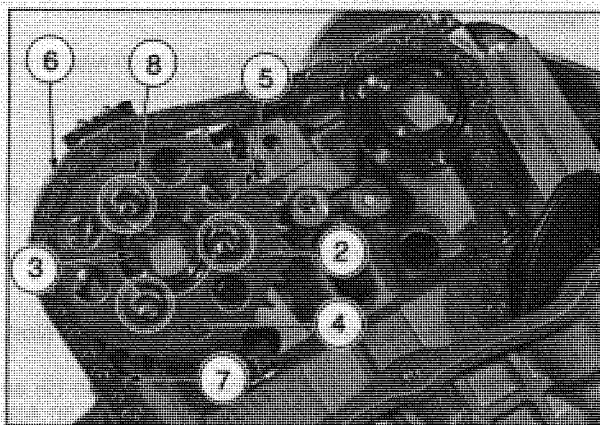
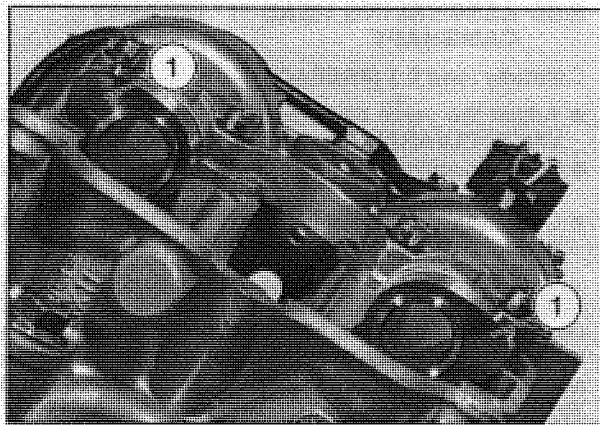

6.22 ASSEMBLING THE VALVE COVER

Carefully read 6.1 (PREFACE).

- ◆ Coat the cable (1) of the camshaft sensor and grommet (2) with SILASTIC 732 RTV.
- ◆ Apply a thin coat of grease to the valve cover gasket (3) and insert in the groove of the valve cover (4).
- ◆ Place the valve cover (4) on head "1" (front) and on head "2" (rear), securing them with the five M6 special screws (5).

M6 special screws tightening torque: 6.5 ftlb (9 Nm).

- ◆ Secure the intake manifold (6) with the two M8 Allen screws (7) and respective washers.

Screws tightening torque: 13.7 ftlb (19 Nm).

NOTE Apply a couple of drops of LOCTITE® 243 to the threads of the two M10 nuts.

- ◆ Secure the support bracket (8) with the two M10 Allen screws (9), fasten the two M10 nuts.

M10 screw/nut tightening torque: 29 ftlb (40 Nm).

B = LOCTITE® 243.
Q = SILASTIC 732 RTV.

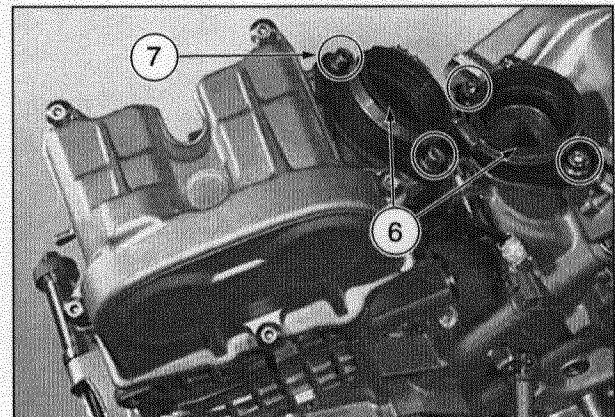
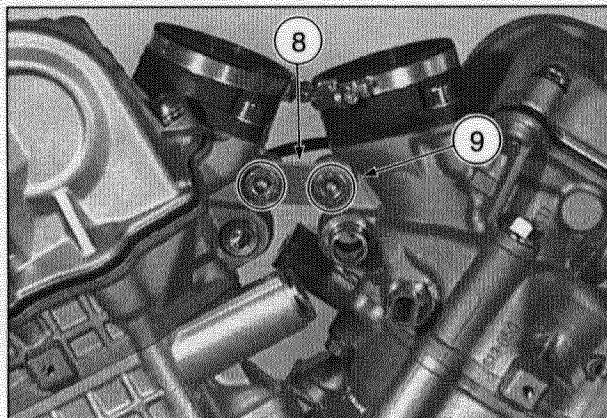
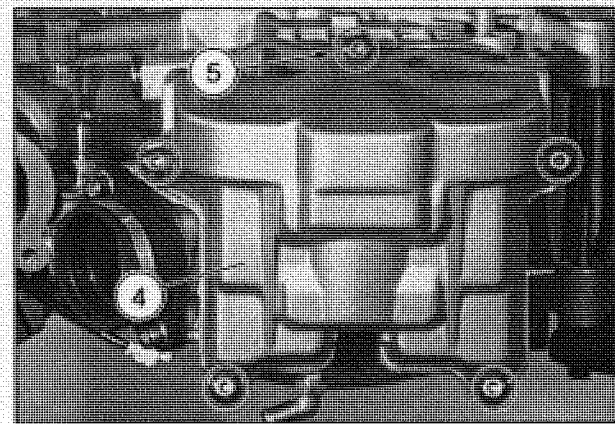
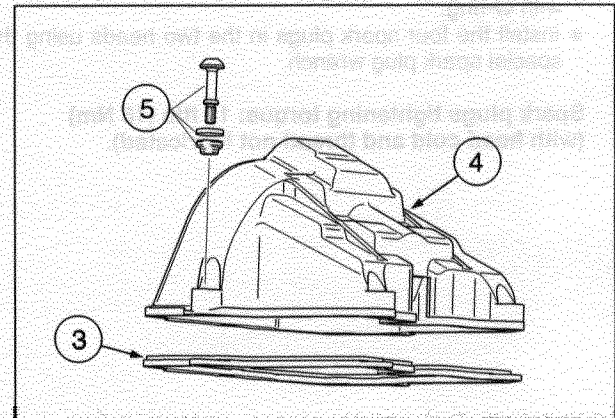
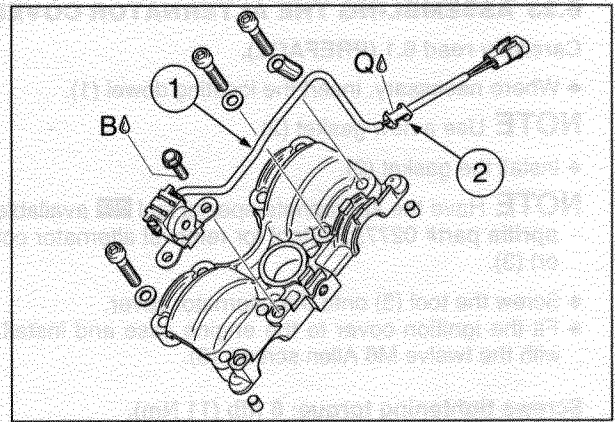

6.23 ASSEMBLING THE ALTERNATOR COVER

Carefully read 6.1 (PREFACE).

- ◆ Where necessary, insert the locating dowel (1).

NOTE Use a new gasket (2).

- ◆ Install the gasket (2).

NOTE Have the appropriate special tool **OPT** available:
 – **aprilia** part# 0277252 (tool for removal alternator cover) (3).

- ◆ Screw the tool (3) onto the alternator cover.
- ◆ Fit the ignition cover to the engine case and install it with the twelve M6 Allen screws (5).

Screws tightening torque: 8 ftlb (11 Nm).

- ◆ Remove the tool (3) and tighten the plug (6) complete with O-ring.
- ◆ Install the four spark plugs in the two heads using the special spark plug wrench.

Spark plugs tightening torque: 13 ftlb (18 Nm)
 (with head cold and thread not lubricated).

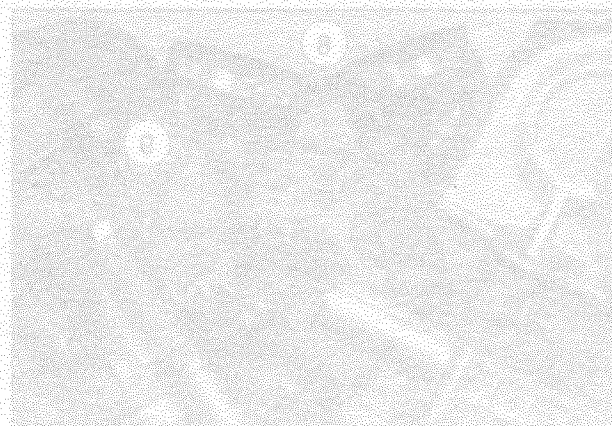
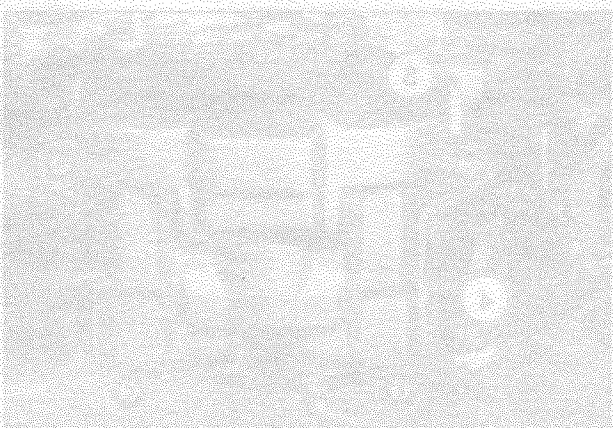
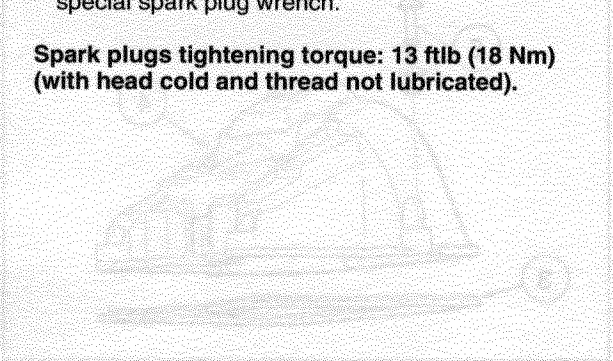
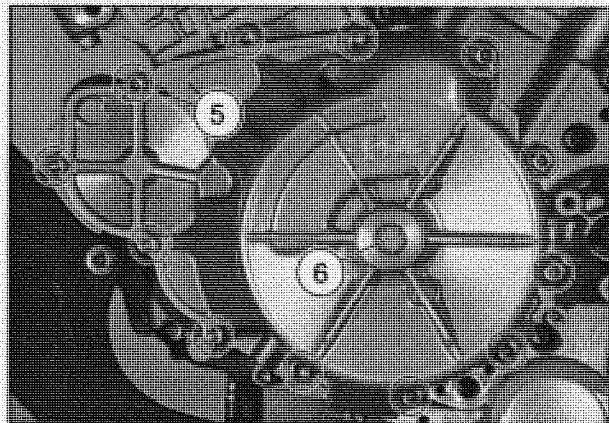
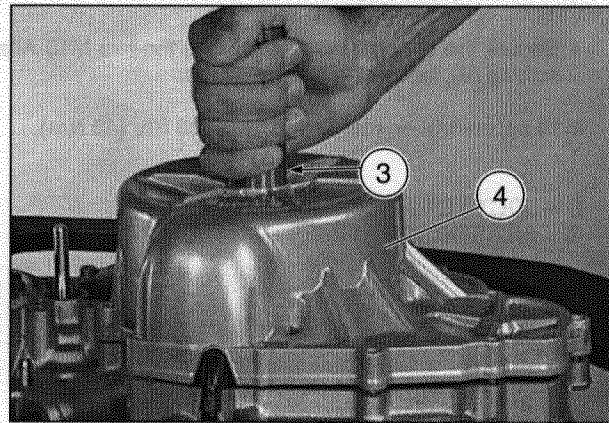
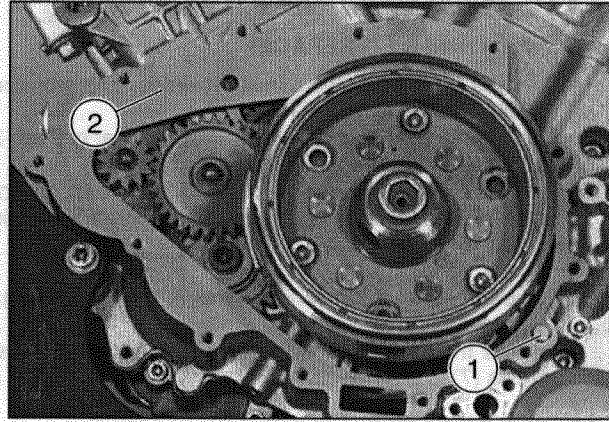

6.24 ASSEMBLING THE CLUTCH HOUSING

Carefully read 6.1 (PREFACE).

- ◆ Remove the threaded bolt (1) for retaining the shaft at TDC.
- ◆ Insert the two locating dowels (2).
- ◆ Fit the gasket (3) in place.

NOTE Use a new gasket.

- ◆ Coat the end of the crankshaft (4) and the end of the lower balancershaft (5) with MOLYKOTE® G-N.
- ◆ Install the clutch cover (6), complete with coolant pump on the engine case.

NOTE Turn the impeller (8) to enable the teeth of the pump gear (7) to mate with the teeth of the coolant pump idling gear (9).

NOTE Fit the seal (13) on the M8x65 Allen screw (12).

Install the:

- eleven M6 x 35 screws (10),
- three M8 x 55 screws (11),
- one M8 x 65 screw (12) with the seal (13),

in the clutch cover and secure them.

Tightening torque:

- M6 Allen screws (10) 8 ftlb (11 Nm);
- M8 Allen screws (11 - 12) 13.7 ftlb (19 Nm).

NOTE Apply a couple of drops of LOCTITE® 243 to the threads of the M6x55 Allen screw (16) place in the center of the cover.

NOTE Fit the seal (18) on the M6x25 Allen screw (17) (coolant drain plug).

- ◆ Install the specially shaped gasket (14) in the coolant pump case groove (15), and fit it to the clutch cover, securing it with the:

- three M6 x 55 screws (16);
- one M6 x 25 screw (17) with the seal (18).

Screws tightening torque: 8 ftlb (11 Nm).

B = LOCTITE® 243.

Follow ►

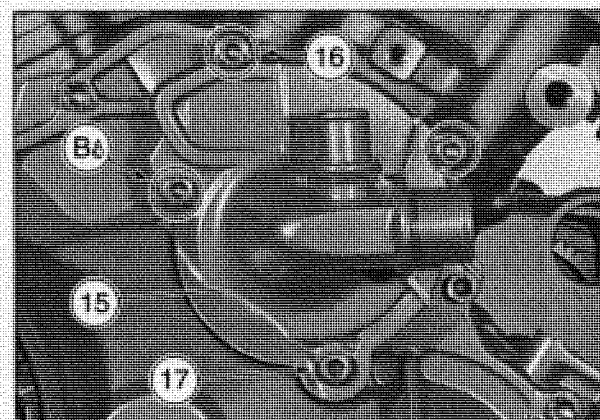
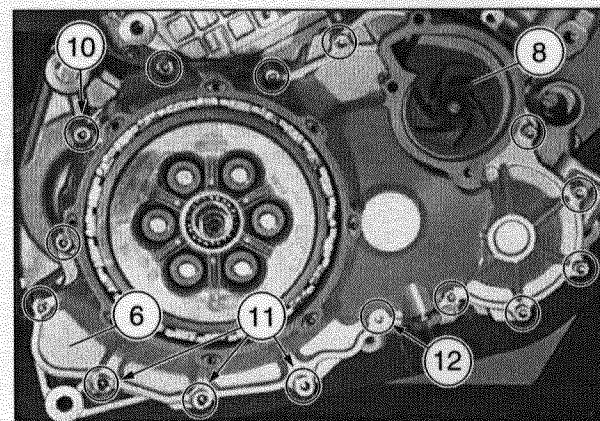
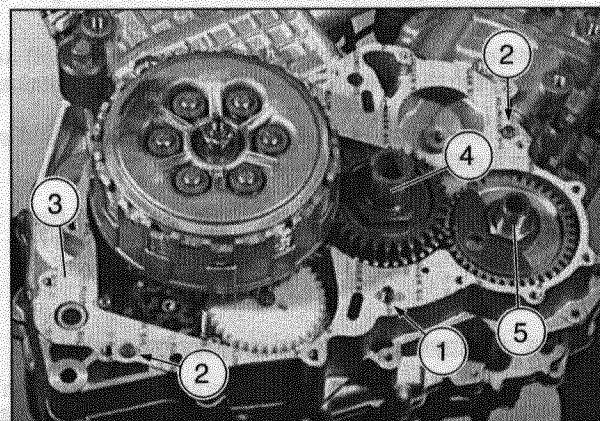
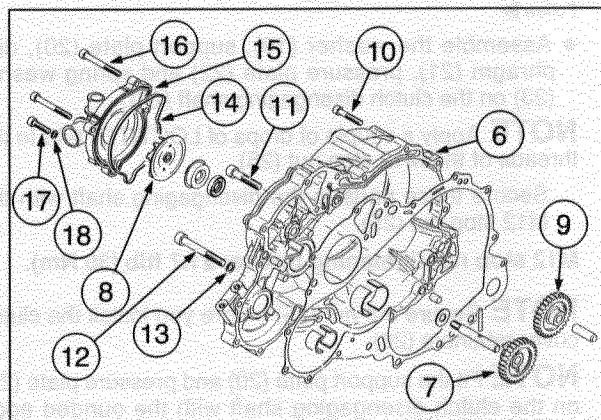

Follow ►

- ◆ Assemble the washer (19), support plate (20), diaphragm (21), pressure plate (22) and spring washer (23) on the clutch disengaging shaft (24).

NOTE Apply a couple of drops of LOCTITE® 648 to the threads of the M12 stop nut (25).

Secure these parts to the disengaging shaft with the M12 stop nut (25).

M12 stop nut tightening torque: 21.7 ftlb (30 Nm).

NOTE Secure the nut (25) before you install the clutch cover retainers (26).

NOTE Fit the support plate (20) and pressure plate (22) on the clutch disengaging shaft with the rounded edge (27) facing out.

NOTE Prevent the diaphragm (21) from rotating on the clutch disengaging shaft (24), with an Allen wrench.

- ◆ Rotate the complete clutch disengaging shaft (24) and fasten the diaphragm (21) in the clutch cover retainers (26).
- ◆ Insert the pre-assembled diaphragm disc (28) and secure it with the eight M5 Allen screws (29).

M5 Allen screws tightening torque: 3.6 ftlb (5 Nm).

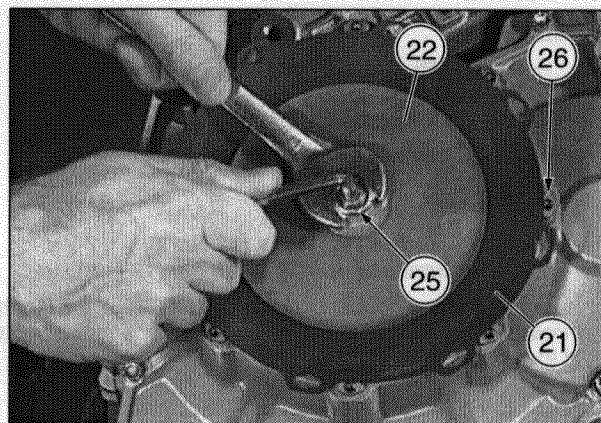
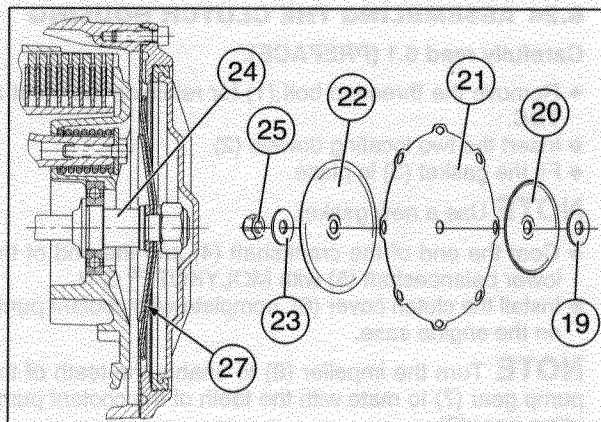

6.25 ASSEMBLING THE STARTER MOTOR

Consult the corresponding paragraph in the section 3 (ENGINE) of specific vehicle workshop manual, see 0.4.1 (VEHICLE WORKSHOP MANUAL).

6.26 ASSEMBLING THE ENGINE OIL FILTER

Consult the section 2 (SERVICE AND SETTING UP) of specific vehicle workshop manual see 0.4.1 (VEHICLE WORKSHOP MANUAL).

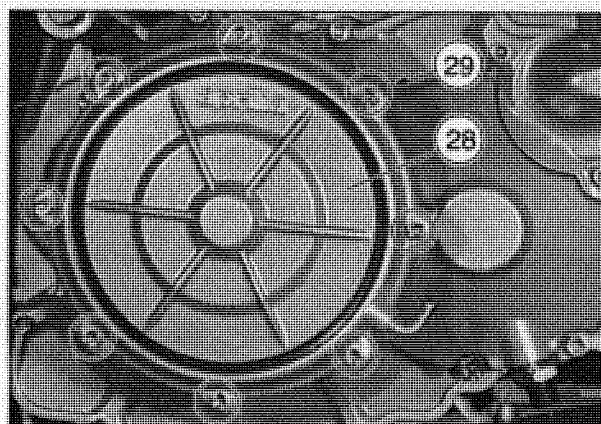
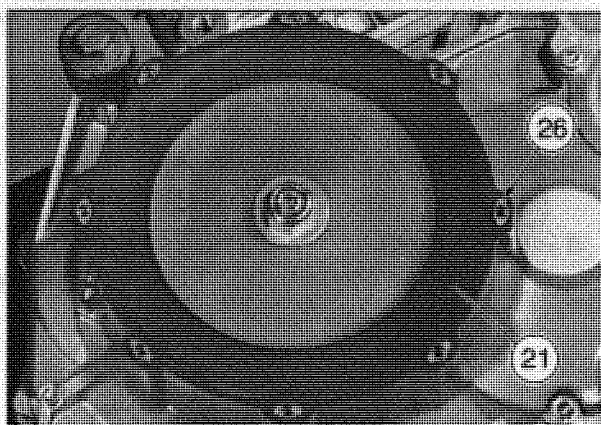

NOTE

NOTE: PACKAGE HAS BEEN INTENTIONALLY LEFT EMPTY.

NOTE

Horizontal lines for notes, with a diagonal watermark reading: THIS PAGE HAS BEEN INTENTIONALLY LEFT EMPTY

**FUEL SYSTEM, COOLING SYSTEM,
ELECTRICAL SYSTEM**

7

**FUEL SYSTEM, COOLING SYSTEM,
ELECTRICAL SYSTEM**

NOTE

Lined area for notes, consisting of approximately 25 horizontal lines.

TABLE OF CONTENTS

7.1 FUEL SYSTEM 7-2-00

7.2 COOLING SYSTEM 7-2-00

7.3 ELECTRICAL SYSTEM 7-2-00

7.1 FUEL SYSTEM

Consult the corresponding section in the specific vehicle workshop manual, see 0.4.1 (VEHICLE WORKSHOP MANUAL).

7.2 COOLING SYSTEM

Consult the corresponding section in the specific vehicle workshop manual, see 0.4.1 (VEHICLE WORKSHOP MANUAL).

7.3 ELECTRICAL SYSTEM

Consult the corresponding section in the specific vehicle workshop manual, see 0.4.1 (VEHICLE WORKSHOP MANUAL).



TROUBLESHOOTING

8

TROUBLESHOOTING

TABLE OF CONTENTS

8.1 TROUBLESHOOTING 8-2-00

8.1 TROUBLESHOOTING

Consult the corresponding section in the specific vehicle workshop manual, see 0.4.1 (VEHICLE WORKSHOP MANUAL).

NOTE

Lined area for notes, consisting of multiple horizontal lines.



ANALYTICAL INDEX



ANALYTICAL INDEX

A	Rif.	Page
ABBREVIATIONS	0.5	0-7-00
ALTERNATOR (RST) (ETV)	5.35	5-53-01
ALTERNATOR (RSV) (RSVR) (SL)	5.34	5-51-00
ALTERNATOR AND STARTER MOTOR DRIVE ASSEMBLY - (ASSEMBLING)	6.18	6-23-00
ALTERNATOR COVER - (ASSEMBLING)	6.23	6-30-00
ALTERNATOR COVER - (REMOVING)	4.8	4-14-00
ALTERNATOR ROTOR (RST) (ETV)	5.35.5	5-53-03
ALTERNATOR ROTOR (RSV) (RSVR) (SL)	5.34.5	5-53-00
ALTERNATOR SYSTEM - (REMOVING)	4.8	4-14-00

B	Rif.	Page
BALANCESHAFT (LOWER)	5.13	5-20-00
BALANCESHAFT (LOWER) - (ASSEMBLING)	6.5	6-4-00
BALANCESHAFT (LOWER) - (DISASSEMBLING)	4.18	4-22-00
BALANCESHAFT (LOWER) MAIN BUSHINGS	5.4	5-7-00
BALANCESHAFT (LOWER) MECHANISM	5.13	5-20-00
BALANCESHAFT (LOWER) MECHANISM - (DISASSEMBLING)	4.13	4-18-00
BALANCESHAFT (UPPER)	5.27	5-40-00
BALANCESHAFT (UPPER) BALL BEARINGS - (DISASSEMBLING AND REASSEMBLING)	5.28	5-41-00
BALANCESHAFT (UPPER) OIL SEAL - (DISASSEMBLING AND REASSEMBLING)	5.28	5-41-00
BALANCESHAFT MECHANISM - (DISASSEMBLING)	4.13	4-18-00
BEARINGS	5.21	5-30-00
	5.26	5-38-00
BEARINGS (MOUNTED ONTO ENGINE HALF-CASES)	5.3	5-5-00

C	Rif.	Page
CAM DRIVE ASSEMBLY	5.23	5-34-00
CAM OPERATING MECHANISM FOR THE REAR CYLINDER (CYLINDER "2") - (ASSEMBLING)	6.10	6-9-00

CAMSHAFT	5.26	5-38-00
CAMSHAFT (FRONT HEAD) - (ASSEMBLING)	6.20	6-27-00
CAMSHAFT (REAR HEAD) - (ASSEMBLING)	6.15	6-18-00
CAMSHAFTS FEATURES CLASSIFICATION	5.26.1	5-39-00
CLAMPS	2.8.1	2-14-00
CLUTCH - (CHECKING)	5.17	5-27-00
CLUTCH - (DISASSEMBLING)	4.12	4-17-00
CLUTCH (VERSIONS)	5.16	5-26-00
CLUTCH AND PRIMARY DRIVE - (ASSEMBLING)	6.12	6-12-00
CLUTCH CONTROL FLUID	1.3.5	1-4-00
	1.4.2	1-7-00
CLUTCH COVER	5.20	5-30-00
CLUTCH COVER - (REMOVING)	4.11	4-16-00
CLUTCH HOUSING - (ASSEMBLING)	6.24	6-31-00
CONNECTING RODS - (DISASSEMBLING)	5.11	5-18-00
CONNECTING RODS - (REPLACING AND INSTALLING)	5.12	5-19-00
CONSUMABLES	2.6	2-7-00
CONSUMABLES (PRODUCT PROPERTIES)	2.6.1	2-7-00
CONSUMABLES (USE)	2.6.2	2-8-00
COOLANT PUMP	5.22	5-32-00
COOLANT PUMP DRIVE - (ASSEMBLING)	6.11	6-11-00
COOLING SYSTEM	7.2	7-2-00
COUNTERSHAFT SPROCKET	5.37	5-53-04
CRANKSHAFT	5.10	5-16-00
CRANKSHAFT - (ASSEMBLING)	6.5	6-4-00
CRANKSHAFT - (DISASSEMBLING)	4.18	4-22-00
CRANKSHAFT (MAIN BUSHINGS)	5.4	5-7-00
CYLINDER	5.31	5-47-00
CYLINDER "1" (FRONT) AND PISTON - (ASSEMBLING)	6.19	6-24-00
CYLINDER "1" (FRONT) TIMING DRIVE ASSEMBLY - (DISASSEMBLING)	4.9	4-15-00
CYLINDER "1" (FRONT), HEAD AND PISTON - (DISASSEMBLING)	4.6	4-8-00
CYLINDER "2" (REAR) TIMING DRIVE ASSEMBLY - (DISASSEMBLING)	4.14	4-19-00
CYLINDER "2" (REAR), HEAD AND PISTON - (DISASSEMBLING)	4.7	4-11-00

D	Rif.	Page
DRIVE GEAR - (DISASSEMBLING)	4.13	4-18-00

E	Rif.	Page
ELECTRICAL SYSTEM	7.3	7-2-00
ENGINE (CAMSHAFT)	5.24	5-35-00
ENGINE - (CHECKS SUBSEQUENT TO REASSEMBLY)	6.3	6-3-00
ENGINE - (DISASSEMBLING)	4	4-2-00
ENGINE - (DISASSEMBLY SEQUENCE)	4.4	4-6-00
ENGINE (HEAD AND CAMSHAFT)	5.24	5-35-00
ENGINE (MARKS ON THE ENGINE PARTS)	4.3.8	4-5-00
ENGINE - (PARTS WHICH CAN BE DISASSEMBLED WITHOUT REMOVING THE ENGINE FROM THE FRAME)	3.2	3-2-00
ENGINE - (REASSEMBLING)	6	6-2-00
ENGINE - (REASSEMBLY SEQUENCE)	6.2	6-3-00
ENGINE - (REFITTING THE ENGINE TO THE FRAME)	3.4	3-2-00
ENGINE - (REMOVING THE COMPLETE ENGINE FROM THE FRAME)	3.3	3-2-00
ENGINE - (WORK ON THE INDIVIDUAL PARTS)	5	5-2-00
ENGINE CASE	5.2	5-3-00
ENGINE CASE - (SPLITTING)	4.17	4-22-00
ENGINE CASES - (ASSEMBLING)	6.6	6-5-00
ENGINE HALF-CASE (ALTERNATOR SIDE)	-	5-4-00
ENGINE HALF-CASE - (ASSEMBLING)	5.7	5-13-00
ENGINE HALF-CASE (CLUTCH SIDE)	-	5-4-00
ENGINE HALF-CASE CYLINDRICAL PINS - (REPLACING)	5.5	5-12-00
ENGINE OIL FILTER - (ASSEMBLING)	6.26	6-32-00
ENGINE OIL FILTER - (REMOVING)	4.10	4-15-00

F	Rif.	Page
FASTENERS	2.8	2-14-00
FUEL SYSTEM	7.1	7-2-00

G	Rif.	Page
GEAR SELECTION	5.15	5-26-00
GEAR SELECTION MECHANISM - (ASSEMBLING)	6.7	6-6-00

GEAR SELECTION MECHANISM - (CHECKING)	6.8	6-7-00
GEAR SELECTION MECHANISM - (DISASSEMBLING)	4.16	4-21-00
GEARBOX	5.14	5-21-00
GEARBOX - (ASSEMBLING)	6.4	6-3-00
GEARBOX - (DISASSEMBLING)	4.19	4-23-00
GUDGEON PIN	5.32	5-48-00

H	Rif.	Page
-	-	-

I	Rif.	Page
IDENTIFICATION DATA	2.1	2-3-00
INITIALS	0.5	0-7-00

J	Rif.	Page
-	-	-

K	Rif.	Page
-	-	-

L	Rif.	Page
LUBRICANT CHART	2.5	2-6-02
LUBRICANTS	4.3.5	4-4-00

M	Rif.	Page
MANUAL - (HOW TO CONSULT IT)	0.2	0-5-00
MANUAL - (HOW TO USE YOUR SERVICE AND REPAIR MANUAL)	1.5	1-9-00
MANUAL GENERAL LIST	0.1.2	0-3-00

N	Rif.	Page
NEUTRAL GEAR INDICATION	5.6	5-12-00

O	Rif.	Page
OIL FILTER - (REMOVING)	4.10	4-15-00
OIL PUMP - (ASSEMBLING)	6.9	6-8-00
OIL PUMP (ASSEMBLY)	5.9	5-14-00

ANALYTICAL INDEX

V990 engine **USA**

OIL PUMP - (REMOVING)	4.15	4-20-00
OIL PUMP DRIVE (ASSEMBLY)	5.9	5-14-00
OIL SEALS (MOUNTED ONTO ENGINE HALF-CASES)	5.3	5-5-00
OIL-SPRAY PIPE	5.8	5-13-00

P

	Ref.	Page
PISTON	5.32	5-48-00
PISTON AND CYLINDER "1" (FRONT) - (ASSEMBLING)	6.19	6-24-00
PISTON AND REAR CYLINDER - (ASSEMBLING)	6.13	6-14-00
PISTONS FEATURES CLASSIFICATION	5.32.1	5-49-01
PRIMARY DRIVE - (DISASSEMBLING)	5.19	5-29-00
PRIMARY DRIVE (VERSIONS)	5.18	5-28-01
PRIMARY DRIVE AND CLUTCH - (ASSEMBLING)	6.12	6-12-00

Q

- - -

R

	Ref.	Page
REAR CYLINDER (CYLINDER "2") - (ASSEMBLING THE CAM OPERATING MECHANISM)	6.10	6-9-00
REAR CYLINDER AND PISTON - (ASSEMBLING)	6.13	6-14-00
REGULAR SERVICE INTERVAL CHART	2.2	2-3-00
RELEASE (UPDATES)	0.1	0-3-00

S

	Ref.	Page
SAFETY RULES (GENERAL)	1.3	1-4-00
SAFETY RULES (SPECIFIC)	1.4	1-7-00
SEALANTS	4.3.4	4-4-00
SPARE PARTS	2.3	2-4-00
SPARE PARTS (CATALOGUE)	0.4.2	0-6-00
SPARE PARTS (REQUEST)	1.5.2	1-9-00
SPARK PLUGS	5.36	5-53-04
SPECIAL TOOLS	2.7	2-10-00
SPECIAL TOOLS (CATALOGUE)	0.4.3	0-6-00
SPRAG CLUTCH (RST) (ETV) - (ASSEMBLING)	5.35.8	5-53-03

SPRAG CLUTCH (RST) (ETV) - (CHECKING)	5.35.6	5-53-03
SPRAG CLUTCH (RST) (ETV) - (DISASSEMBLING)	5.35.7	5-53-03
SPRAG CLUTCH (RSV) (RSVR) (SL) - (ASSEMBLING)	5.34.8	5-53-00
SPRAG CLUTCH (RSV) (RSVR) (SL) - (CHECKING)	5.34.6	5-53-00
SPRAG CLUTCH (RSV) (RSVR) (SL) - (DISASSEMBLING)	5.34.7	5-53-00
STARTER MOTOR	5.38	5-53-04
STARTER MOTOR - (ASSEMBLING)	6.25	6-32-00
STARTER MOTOR - (REMOVING)	4.5	4-7-00
STARTER MOTOR DRIVE ASSEMBLY	5.33	5-50-00
STARTER MOTOR DRIVE ASSEMBLY AND ALTERNATOR - (ASSEMBLING)	6.18	6-23-00
STATOR (RST) (ETV) - (ASSEMBLING)	5.35.4	5-53-02
STATOR (RST) (ETV) - (CHECKING)	5.35.2	5-53-02
STATOR (RST) (ETV) - (DISASSEMBLING)	5.35.3	5-53-02
STATOR (RSV) (RSVR) (SL) - (ASSEMBLING)	5.34.4	5-52-00
STATOR (RSV) (RSVR) (SL) - (CHECKING)	5.34.2	5-52-00
STATOR (RSV) (RSVR) (SL) - (DISASSEMBLING)	5.34.3	5-52-00
SYMBOLS	0.5	0-7-00

T

	Ref.	Page
TECHNICAL DATA	2.4	2-4-00
TECHNICAL INFORMATION	4.3	4-4-00
TIGHTENING TORQUE	4.3.7	4-4-00
TIGHTENING TORQUES (GENERAL VALUES)	2.8.2	2-15-00
TIGHTENING TORQUES (SPECIFIC VALUES)	2.8.3	2-16-00
TIMING DRIVE ASSEMBLY (FRONT HEAD) - (ASSEMBLING)	6.17	6-21-00
	6.21	6-28-00
TIMING DRIVE ASSEMBLY (REAR HEAD) - (ASSEMBLING)	6.16	6-19-00
TROUBLESHOOTING	8.1	8-2-00

U

- - -

V	Rif.	Page
VALVE CLEARANCE - (ADJUSTING)	6.14	6-17-00
VALVE COVER - (ASSEMBLING)	6.22	6-29-00
VALVE GUIDES	5.29	5-42-00
VALVES	5.30	5-44-00
VALVES (INTAKE AND EXHAUST) - (DISASSEMBLING)	5.25	5-36-00

W	Rif.	Page
WORKSHOP MANUAL (OF SPECIFIC VEHICLE)	0.4.1	0-6-00

X	Rif.	Page
-	-	-

Y	Rif.	Page
-	-	-

Z	Rif.	Page
-	-	-

NOTES

Lined area for notes, containing a large diagonal watermark: THIS PAGE HAS BEEN INTENTIONALLY LEFT EMPTY