

aprilia

Caponord Rally Raid  
adventure motorcycle

www.aprilia.com



Caponord RALLY  
RAID





Style and technology, comfort and adventure, touring and enduro, the Caponord Rally Raid combines two worlds in one total extreme machine. Only the Caponord Rally Raid is capable of conveying limitless sensations and taking you wherever you dream of going. In the Rally Raid version, Aprilia's pace setting maxi enduro is even more versatile, exciting and comfortable than ever. And it comes with all the equipment you need could possibly need for the greatest adventure of your life ... your next journey!



*Capomaid* FALL  
**RAID**

Dirt tracks or  
miles of asphalt.  
It's up to you!





64°N

56°N

48°N

40°N

32°N

24°N

16°N

8°N

0°N

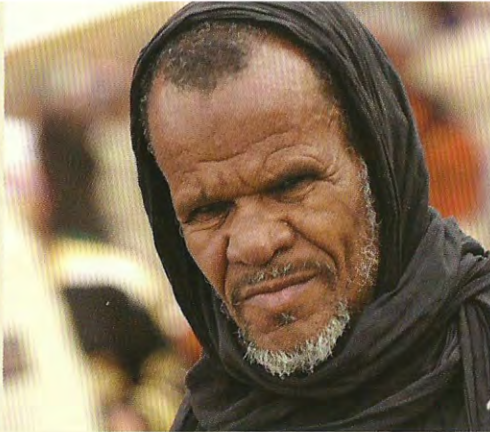







Caponord RAILLY  
**RAID**

















Canyonral Rally  
RAID





Canyon BALLY  
RAID





64°N

Prestige plus extreme riding ergonomics.

56°N

The Rally Raid extends the already distant horizons and incredible potential of the standard Caponord with a series of modifications and special components designed to tackle the most demanding offroad journeys. The riding position is new: seat height of 860 mm gives better visibility and makes riding on the footrests even easier than before. The seat is shaped like professional cross and enduro seats, with a narrow profile and no steps between the rider and passenger parts to make movement while riding far easier. The rubber sleeves can be removed from the footrests for better control when riding in motocross boots. The handlebars are new too. Their twin taper anodised aluminium design combines minimum weight with maximum stability and flexural strength. The updated handlebars also match the new riding position. Redesigned hand guards provide protection from roadside branches and the elements. The higher, single piece risers feature rubber mountings to absorb even the worst vibrations and hardest knocks. The Caponord Rally Raid expresses its vocation for adventure with a new cockpit fairing too, completely redesigned to reduce the bike's overall dimensions, and with a new front mudguard, specially shaped to prevent mud from building up during long offroad journeys.

48°N

40°N

32°N

24°N

16°N

8°N

0°N



The suspensions on to the Caponord Rally Raid have been completely renewed and are similar to those of top motocross machines. The Rally Raid is the only maxi twin equipped as standard with a Marzocchi 50 mm fork with 200 mm wheel travel and with independent hydraulic adjustments for compression (on the right leg) and rebound (on the left leg). The fork's piston and cartridge internals are exactly like those used in motocross forks.

The Sachs monoshock at the rear now permits extended wheel travel of 200 mm. A nitrogen reservoir keeps operating temperatures low and efficiency high. This high performance monoshock uses the same practical preload adjuster knob that is fitted to the standard Caponord and also incorporates hydraulic adjustments for compression and rebound.

The aluminium alloy swinging arm features a new rising rate linkage with APS (Aprilia Progressive System) to adapt the suspension to all riding conditions, from all up road riding to sports offroad.





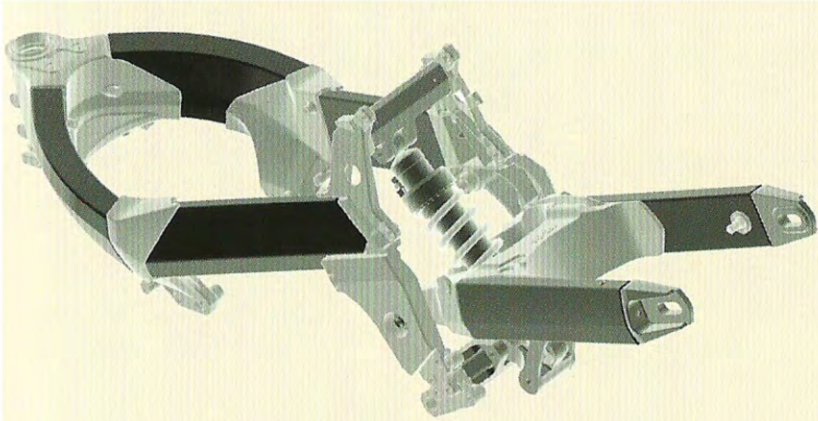

Just like the basic Caponord, the Rally Raid is equipped with a frame which can only be described as a jewel of technology. **The Double Wave Aluminium Beam** frame is in extruded and reinforced **aluminium magnesium alloy**, and features variable geometry to guarantee the highest coefficient of torsional rigidity in its class. The shape of the frame also enhances the riding position and eliminates aerodynamic turbulence around the rider. The **aluminium magnesium alloy swinging arm** incorporates a chilled cast main section, extruded members and forged ends. Like the rest of the frame this advanced swinging arm offers an optimum strength to weight ratio.

The transmission system is another area of improvement, and now includes a **16 tooth front sprocket** for faster acceleration and a first gear ratio optimised for difficult offroad situations. Riders who wish to keep their revs down on long motorway journeys can fit a 17 tooth sprocket instead of the standard 16 tooth one.

Even the brakes have been beefed up for more extreme use. **The stainless steel** front disks are now **300 mm** in diameter, and float for even better stress absorption as well as improved feel and control, specially offroad.



The compact, **powerful and smooth longitudinal 60° V twin** features **4 valves per cylinder**, double overhead cams and dry sump lubrication, and combines Aprilia's inimitable sports performance with the exceptionally smooth and even power delivery that you need to tackle long - even record breaking - journeys. Different injection mapping for the two cylinders and tuned intake and exhaust systems have improved power delivery at low revs without reducing the maximum power rating of 98 HP. On top of this, the sophisticated **DIAC (Dynamic Ignition Advance Control)** system controls ignition and fuel injection parameters according to riding and environmental conditions.

This engine is also famous for Aprilia's patented **AVDC (Anti Vibration Double Countershaft)** double balancer shaft system and **PPC (Pneumatic Power Clutch)** system that reduces clutch lever force and eliminates rear wheel bounce during hard braking.

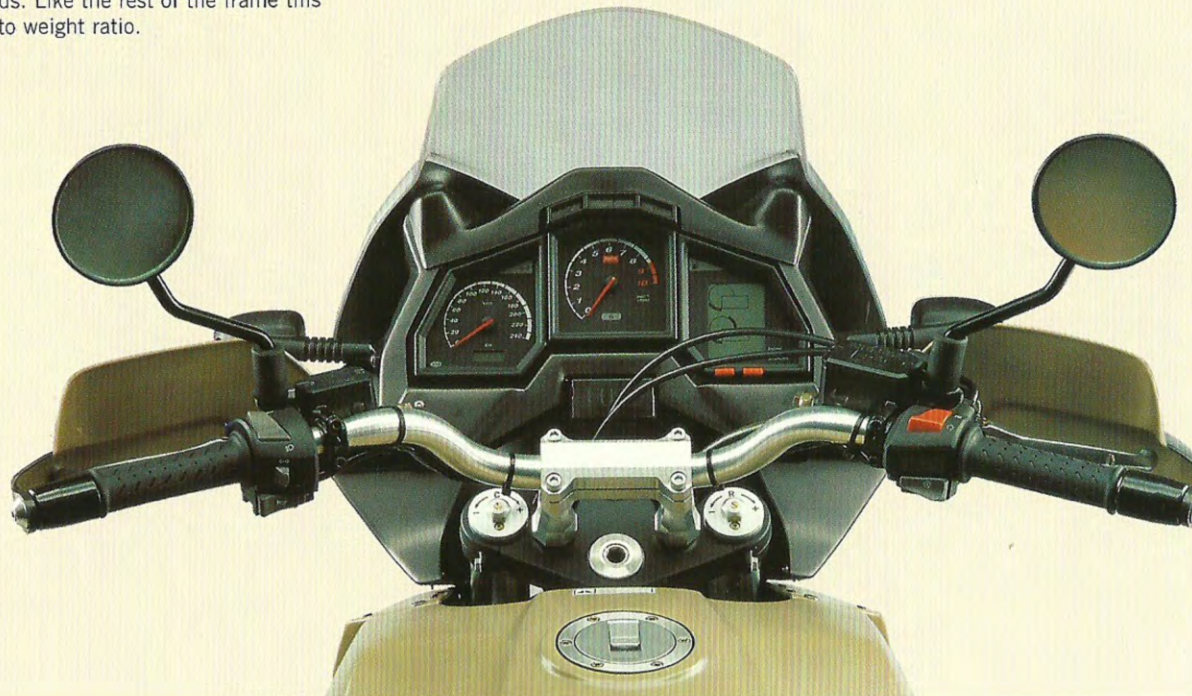

**The dashboard** features adjustable intensity backlighting and is easy to read under all conditions. The multifunctional digital panel allows you to monitor all operating parameters and keep everything under control. Finally, the powerful generator provides plenty of current for the free form multi-focal headlight cluster and power to spare for accessories like satellite phones, video cameras or portable PCs through a practical 12 V socket. The Caponord Rally Raid heralds a new era in adventure motorcycling.





Caponord FULLY  
**RAID**

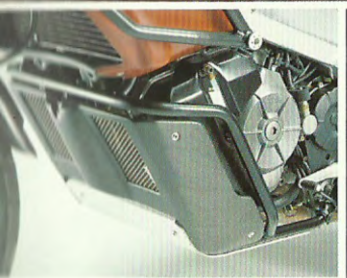



# Caponord Rally Raid accessori

**CAPONORD RALLY RAID: original accessories.** A range of accessories designed, made and tested by APRILIA specially for the Caponord Rally Raid and available only from your official Aprilia dealer. The Caponord Rally Raid comes with a generous range of standard accessories but can also be equipped with a number of practical optionals to help you tackle challenging journeys and cope with the unexpected.

**ALUMINIUM TOP BOX  
LOW SEAT**



Complete with mounting rack and lock. Designed for maximum practicality and strength. 30 litre capacity.

**Low rider seat**

This seat, with a reduced height of 820 mm, ensures better control of the motorcycle in all riding conditions and makes it easier for shorter riders to get their feet firmly on the ground.

**Low passenger seat**

For greater comfort on long journeys.

**PROTECTIVE HEADLIGHT  
GRILLE**



For offroad use only. Protects the headlight cluster from damage by impacts with stones, branches and other objects.

**HEATED HAND GRIPS  
HAZARD WARNING FLASHERS**



Indispensable for riding in cold climates. Ensure maximum comfort and safety in conjunction with the standard hand guards.

Indispensable for safety in the event of unforeseen stops and slow riding, especially in poor visibility.



**TANK BAG**



The ideal luggage item for short trips and long distance touring. Expands upwards to give a total capacity of 23 litres. Quick release mechanism. Can be carried as shoulder bag. Made from high strength nylon, with a non-scratch bottom to avoid spoiling the finish of your tank. Clear top pocket for maps, etc.. Rain hood for total weather-proofing. Elegantly customised with the Aprilia logo and a red reflective strip.

**X-BOX TOP BOX**



50 litres of load carrying capacity. Ideal for transporting a large number of personal effects, all held neatly in place with the internal cross straps. Can also hold two full face helmets. Practical single lock system with just one key for fitting, removing, opening and closing. Available only in Extra-Strong Grey finish. Made from impact, scratch and wear resistant polypropylene. Guaranteed water-proof thanks to the perfect seal between the strong embossed base and the elegantly painted lid. Complete with rear reflector for improved passive visibility at night.

**BODYGUARD ARMOURD  
CABLE LOCK**



Produced in partnership between Aprilia and European leader Trelock, the BodyGuard ensures maximum security thanks to its surface hardened 25 mm diameter links. A plastic sheath covers the steel cable to protect the bike's paintwork against knocks and scratches. Easy to use in all situations thanks to 1 metre length. The frame mounted locking pin is Aprilia's own patented security solution, but the BodyGuard can also be used in a standard configuration with steel locking knob. Customised with the Aprilia logo. Can be carried easily in the panniers or top box.





# Caponord Rally Raid



<b>Engine type</b>	Longitudinal 60° V twin four stroke, with patented AVDC system (Anti-Vibration Double Countershaft)
<b>Cooling</b>	Liquid cooling with three-way pressurised circuit.
<b>Bore and stroke</b>	97 x 67,5 mm
<b>Total displacement</b>	997,62 cc
<b>Compression ratio</b>	10.4 :1
<b>Valve timing</b>	Double overhead cam with mixed gear/chain timing drive, four valves per cylinder.
<b>Maximum power at crankshaft</b>	98 HP (72 kW) at 8,250 r.p.m.
<b>Maximum torque at crankshaft</b>	9.68 kgm (95 Nm) at 6,250 r.p.m.
<b>Fuel injection</b>	Integrated electronic engine management system. Indirect multi-point electronic injection. Lambda probe oxygen sensor in exhaust system. 47 mm diameter throttle bodies.
<b>Ignition</b>	Digital electronic ignition with TSI (Twin Spark Ignition) with two spark plugs per cylinder. Ignition timing integrated in the injection control system.
<b>Exhaust system</b>	Twin stainless steel silencers, one catalyser per silencer.
<b>Starter</b>	Electric starter
<b>Lubrication</b>	Dry sump with separate oil reservoir. Double trochoidal pump with oil cooler. Circuit capacity 3.5 litres.
<b>Primary drive</b>	Straight toothed gears. Transmission ratio: 60/31 (1.935)
<b>Gearbox</b>	6 speed. Transmission ratios: 1° 35/14 (2,5), 2° 28/16 (1,75), 3° 26/19 (1,368), 4° 24/22 (1,091), 5° 22/23 (0,957), 6° 23/27 (0,852)
<b>Final drive</b>	Chain. Transmission ratio: 45/16. Alternative 17 tooth sprocket can be fitted.
<b>Clutch</b>	Multiple disk in oil bath with patented PPC power-assisted hydraulic control.

<b>Frame</b>	Sloping parallel twin spar frame in aluminium-magnesium alloy. Removable high strength steel seat mount frame.
<b>Dimension</b>	Maximum length: 2,300 mm. Maximum width: 876 mm (at handlebars). Maximum height: 1,460 mm (at windshield). Seat height: 860 mm Handlebar height: 1,135 mm at bar ends. Wheelbase: 1,568 mm. Trail: 129 mm. Steering angle: 27.8°
<b>Front suspension</b>	Marzocchi 50 mm hydraulic telescopic fork. 200 mm wheel travel. Piston and cartridge motocross type fork hydraulics. Compression adjustment (on RH leg) and rebound adjustment (on LH leg).
<b>Rear suspension</b>	Aluminium alloy swing-arm. New rising rate linkage with APS (Aprilia Progressive System). Sachs hydraulic monoshock with mechanical compression and rebound adjustment and hydraulic preload adjustment. Separate nitrogen reservoir. 200 mm wheel travel.
<b>Front brake</b>	Brembo double floating stainless steel disks, Ø 300 mm. Floating calliper with two differential diameter 32 and 30 mm pistons. Semi-metallic brake pads.
<b>Rear brake</b>	Stainless steel disk, Ø 272 mm. Twin 34 mm piston calliper.
<b>Wheels</b>	Patented perfected spoked wheels for tubeless tyres. Front: 2.50 X 19". Rear: 4.00 X 17".
<b>Tyres</b>	Radial tubeless: Front: 110/80 VR 19. Rear: 150/70 R 17. Alternative: Off road all-round. V max = 170 km/h. Front: 110/80 R 19 M+S Tubeless. Rear: 150/70 R 17 M+S Tubeless.
<b>Electrical system Battery</b>	12 V. 12 V 14 Ah.
<b>Weight</b>	Motorcycle + Rider + Passenger + luggage = 478 kg
<b>Tank</b>	Capacity 25 litres, 5 litre reserve.

ETV 1000 Caponord is an environmentally friendly vehicle conforming to Community Euro 2 standards in respect of acoustic and air pollution limits.

**AWS - UK Branch**  
Unit 15  
Gregory Way  
South Reddish  
Stockport  
SK5 7ST  
Tel. 0161 475 1800



Drive safely always wearing a helmet and protective clothing. Observe the laws of the road and respect the environment. Carefully read the owners' handbook. Photographs, technical data, specifications and colours shown in this brochure refer to the Italian market version and may be subject to change without prior notice. Ask your official Aprilia dealers for full details. In order to maintain your machine in a safe and efficient manner, always demand official Aprilia Spare Parts, which are guaranteed by Aprilia Quality Service in respect of current legislation. E & O E. Aprilia offers Aprilia Road Assistance, a call centre available 24 hours a day for information and road rescue.

aprilia recommends





aprilia

Caponord Rally Raid

adventure motorcycle



Caponord RALLY  
RAID